

MITSUBISHI
PROGRAMMABLE CONTROLLERS
MELSEC-F

Changes for the Better

FX3U-16CCL-M

USER'S MANUAL

CC-Link V2



FX3U

Safety Precautions

(Read these precautions before use.)

Before installation, operation, maintenance or inspection of this product, thoroughly read through and understand this manual and all of the associated manuals. Also, take care to handle the module properly and safely.

This manual classifies the safety precautions into two categories: **DANGER** and **CAUTION**.

 DANGER	Indicates that incorrect handling may cause hazardous conditions, resulting in death or severe injury.
 CAUTION	Indicates that incorrect handling may cause hazardous conditions, resulting in medium or slight personal injury or physical damage.

Depending on the circumstances, procedures indicated by **CAUTION** may also cause severe injury. It is important to follow all precautions for personal safety. Store this manual in a safe place so that it can be taken out and read whenever necessary. Always forward it to the end user.

1. DESIGN PRECAUTIONS



 DANGER	Reference
<ul style="list-style-type: none"> • When executing control (data changes) to an operating PLC, construct an interlock circuit in the sequence program so that the entire system operates conservatively. In addition, when executing control such as program changes and operation status changes (status control) to an operating PLC, thoroughly read the manual and sufficiently confirm safety in advance. Especially in control from external equipment to a PLC in a remote place, problems in the PLC may not be able to be handled promptly due to abnormality in data transfer. Construct an interlock circuit in the sequence program. At the same time, determine the actions in the system between the external equipment and the PLC for protection against abnormalities in data transfer. • Make sure to include the following safety circuits outside the PLC to ensure safe system operation even during external power supply problems or PLC failure. Otherwise, malfunctions may cause serious accidents. <ol style="list-style-type: none"> 1) Above all, the following components should be included: an emergency stop circuit, a protection circuit, an interlock circuit for opposite movements (such as normal vs. reverse rotation), and an interlock circuit (to prevent damage to the equipment at the upper and lower positioning limits). 2) Note that when the PLC main unit detects an error during self diagnosis, such as a watchdog timer error, all outputs are turned off. Also, when an error that cannot be detected by the PLC main unit occurs in an input/output control block, output control may be disabled. External circuits and mechanisms should be designed to ensure safe machinery operation in such cases. 	20 100

 CAUTION	Reference
<ul style="list-style-type: none"> • Observe the following items. Failure to do so may cause incorrect data-writing through noise to the PLC and result in PLC failure, machine damage or other accident. <ol style="list-style-type: none"> 1) Do not bundle the control line together with or lay it close to the main circuit or power line. As a guideline, lay the control line at least 100mm (3.94") or more away from the main circuit or power line. Noise may cause malfunctions. 2) Ground the shield wire or shield of a shielded cable. Do not use common grounding with heavy electrical systems • Do not apply excessive pressure to the power supply terminal block or CC-Link connection terminal block. Excessive pressure may cause damage or error. 	20 100

Safety Precautions

(Read these precautions before use.)

2. INSTALLATION PRECAUTIONS

 DANGER	Reference
<ul style="list-style-type: none">• Make sure to cut off all phases of the power supply externally before attempting installation work. Failure to do so may cause electric shock or damage to the product.	33
 CAUTION	Reference
<ul style="list-style-type: none">• Use the product within the generic environment specifications described in PLC main unit manual (Hardware Edition). Never use the product in areas with excessive dust, oily smoke, conductive dusts, corrosive gas (salt air, Cl₂, H₂S, SO₂, or NO₂), flammable gas, vibration or impacts, or expose it to high temperature, condensation, or rain and wind. If the product is used in such conditions, electric shock, fire, malfunctions, deterioration or damage may occur.• Do not touch the conductive parts of the product directly. Doing so may cause device failures or malfunctions.• Install the product securely using a DIN rail or mounting screws.• Install the product on a flat surface. If the mounting surface is rough, undue force will be applied to the PC board, thereby causing nonconformities.• When drilling screw holes or wiring, make sure that cutting and wiring debris do not enter the ventilation slits. Failure to do so may cause fire, equipment failures or malfunctions.• Be sure to remove the dust proof sheet from the PLC's ventilation port when installation work is completed. Failure to do so may cause fire, equipment failures or malfunctions.• Make sure to attach the top cover, offered as an accessory, before turning on the power or initiating operation after installation or wiring work. Failure to do so may cause electric shock.• Connect extension cables securely to their designated connectors. Loose connections may cause malfunctions.	33

Safety Precautions

(Read these precautions before use.)

3. WIRING PRECAUTIONS

 DANGER	Reference
<ul style="list-style-type: none">• Make sure to cut off all phases of the power supply externally before attempting wiring work. Failure to do so may cause electric shock or damage to the product.	36

 CAUTION	Reference
<ul style="list-style-type: none">• Connect the DC power supply wiring to the dedicated terminal described in this manual. If an AC power supply is connected to a DC input/output terminal or DC power supply terminal, the PLC will burn out.• Perform class D grounding (grounding resistance: 100Ω or less) to the grounding terminal on the FX3U-16CCL-M with a wire as thick as possible. Do not use common grounding with heavy electrical systems.• Make sure to attach the top cover, offered as an accessory, before turning on the power or initiating operation after installation or wiring work. Failure to do so may cause electric shock.• When drilling screw holes or wiring, make sure that cutting and wiring debris do not enter the ventilation slits. Failure to do so may cause fire, equipment failures or malfunctions.• For the CC-Link system, use CC-Link dedicated cables. The performance of the CC-Link system cannot be guaranteed with any cable other than CC-Link dedicated cables. For the maximum total extension length and the cable length between stations, observe the specification described in the Section 2.5. With wiring outside the specification range, normal data transfer cannot be guaranteed.• Do not bundle the CC-Link dedicated cable together with or lay it close to the main circuit, high-voltage line, or load line. As a guideline, lay the control line at least 100mm (3.94") or more away from the main circuit, high-voltage line, or load line. Otherwise, noise disturbance and/or surge induction are likely to take place.• Make sure to fix communication cables and power cables connected to the module by placing them in the duct or clamping them. Cables not placed in duct or not clamped may hang or shift, allowing them to be accidentally pulled, which may result in malfunction or damage to the module and the cables.• When disconnecting a communication/power cable connected to the module, do not hold the cable area. For a cable connected to a terminal block, loosen screws of the terminal block, then disconnect the cable. If a cable is pulled while it is connected to a module, the module may malfunction or the module and the cable may be damaged.• Make sure to properly wire the extension equipment in accordance with the following precautions. Failure to do so may cause electric shock, equipment failures, a short-circuit, wire breakage, malfunctions, or damage to the product.<ul style="list-style-type: none">- The disposal size of the cable end should follow the dimensions described in the manual.- Tightening torque should follow the specifications in the manual.	36

Safety Precautions

(Read these precautions before use.)

4. STARTUP AND MAINTENANCE PRECAUTIONS

 DANGER	Reference
<ul style="list-style-type: none">• Do not touch any terminal while the PLC's power is on. Doing so may cause electric shock or malfunctions.• Before cleaning or retightening terminals, cut off all phases of the power supply externally. Failure to do so may cause electric shock.• Before modifying or disrupting the program in operation or running the PLC, carefully read through this manual and the associated manuals and ensure the safety of the operation. An operation error may damage the machinery or cause accidents.	100 249

 CAUTION	Reference
<ul style="list-style-type: none">• Do not disassemble or modify the PLC. Doing so may cause fire, equipment failures, or malfunctions. For repair, contact your local Mitsubishi Electric representative.• Turn off the power to the PLC before connecting or disconnecting any extension cable. Failure to do so may cause equipment failures or malfunctions.• Turn off the power to the PLC before attaching or detaching the following devices. Failure to do so may cause equipment failures or malfunctions.<ul style="list-style-type: none">- Peripheral devices, display modules, expansion boards and special adapters- I/O extension units/blocks, FX Series terminal block and the special function units/blocks- Battery and memory cassette	100 249

5. DISPOSAL PRECAUTIONS

 CAUTION	Reference
<ul style="list-style-type: none">• Please contact a certified electronic waste disposal company for the environmentally safe recycling and disposal of your device.	20

6. TRANSPORTATION AND STORAGE PRECAUTIONS

 CAUTION	Reference
<ul style="list-style-type: none">• The PLC is a precision instrument. During transportation, avoid impacts larger than those specified in the general specifications of the PLC main unit manual. Failure to do so may cause failures in the PLC. After transportation, verify the operations of the PLC.	20

FX3U-16CCL-M

User's Manual

Manual number	JY997D43601
Manual revision	C
Date	5/2012

Foreword

This manual describes the FX3U-16CCL-M CC-Link master block and should be read and understood before attempting to install the hardware.

Store this manual in a safe place so that you can take it out and read it whenever necessary. Always forward it to the end user.

<p>This manual confers no industrial property rights or any rights of any other kind, nor does it confer any patent licenses. Mitsubishi Electric Corporation cannot be held responsible for any problems involving industrial property rights which may occur as a result of using the contents noted in this manual.</p>
--

Outline Precautions

- This manual provides information for the use of the FX3U-16CCL-M CC-Link master block. The manual has been written to be used by trained and competent personnel. The definition of such a person or persons is as follows;
 - 1) Any engineer who is responsible for the planning, design and construction of automatic equipment using the product associated with this manual should be of a competent nature, trained and qualified to the local and national standards required to fulfill that role. These engineers should be fully aware of all aspects of safety with aspects regarding to automated equipment.
 - 2) Any commissioning or maintenance engineer must be of a competent nature, trained and qualified to the local and national standards required to fulfill the job. These engineers should also be trained in the use and maintenance of the completed product. This includes being familiar with all associated manuals and documentation for the product. All maintenance should be carried out in accordance with established safety practices.
 - 3) All operators of the completed equipment should be trained to use that product in a safe and coordinated manner in compliance with established safety practices. The operators should also be familiar with documentation that is connected with the actual operation of the completed equipment.
- Note:** The term 'completed equipment' refers to a third party constructed device that contains or uses the product associated with this manual.
- This product has been manufactured as a general-purpose part for general industries, and has not been designed or manufactured to be incorporated in a device or system used in purposes related to human life.
 - Before using the product for special purposes such as nuclear power, electric power, aerospace, medicine or passenger movement vehicles, consult with Mitsubishi Electric.
 - This product has been manufactured under strict quality control. However when installing the product where major accidents or losses could occur if the product fails, install appropriate backup or failsafe functions into the system.
 - When combining this product with other products, please confirm the standards and codes of regulation to which the user should follow. Moreover, please confirm the compatibility of this product with the system, machines, and apparatuses to be used.
 - If there is doubt at any stage during installation of the product, always consult a professional electrical engineer who is qualified and trained in the local and national standards. If there is doubt about the operation or use, please consult your local Mitsubishi Electric representative.
 - Since the examples within this manual, technical bulletin, catalog, etc. are used as reference; please use it after confirming the function and safety of the equipment and system. Mitsubishi Electric will not accept responsibility for actual use of the product based on these illustrative examples.
 - The content, specification etc. of this manual may be changed for improvement without notice.
 - The information in this manual has been carefully checked and is believed to be accurate; however, if you notice any doubtful point, error, etc., please contact your local Mitsubishi Electric representative.

Registration

- Microsoft® and Windows® are either registered trademarks or trademarks of Microsoft Corporation in the United States and/or other countries.
- The company name and the product name to be described in this manual are the registered trademarks or trademarks of each company.

Table of Contents

SAFETY PRECAUTIONS	(1)
Standards.....	9
Certification of UL, cUL standards	9
Compliance with EC directive (CE Marking)	9
Associated Manuals.....	12
Generic Names and Abbreviations Used in the Manual	14
Reading the Manual	16

1. Introduction **17**

1.1 Outline.....	17
1.1.1 Outline of CC-Link System	17
1.1.2 Outline of CC-Link Master Block FX3U-16CCL-M	17
1.2 External Dimensions and Part Names	18
1.3 Terminal Layout	19
1.4 Power and Status LEDs	19

2. Specification **20**

2.1 General Specifications	21
2.2 Power Supply Specifications.....	21
2.3 Performance Specification	21
2.4 Communication Specification.....	23
2.4.1 Data transfer between master station and slave station.....	23
2.5 Maximum Transmission Distance	23
2.5.1 Maximum transmission distance (for Ver. 1.00)	23
2.5.2 Maximum transmission distance (for Ver. 1.10)	25
2.6 CC-Link Dedicated Cable.....	25

3. System Configuration **26**

3.1 General Configuration.....	26
3.1.1 CC-Link network configuration	26
3.1.2 Example of CC-Link system configuration.....	27
3.2 Applicable PLC.....	28
3.3 Connection with PLC.....	29
3.4 Number of Occupied Stations and Station numbers as well as Number of Units and Number of Stations	30
3.5 Precautions When Configuring the System	30
3.6 CC-Link Version.....	32

4. Installation **33**

4.1 DIN rail Mounting	34
4.2 Direct Mounting	35

5. Wiring	36
5.1 Power Supply Wiring	37
5.1.1 Power supply wiring	37
5.1.2 Grounding	37
5.2 CC-Link Wiring	38
5.2.1 Unit wiring with CC-Link dedicated cables	38
5.2.2 T-shaped Branch Connection Using CC-Link Dedicated Cables	39
5.3 Screw Size and Tightening Torque	41
5.3.1 Terminal screw size and tightening torque	41
5.3.2 Terminal block mounting screw size and tightening torque	41

6. Introduction of Functions	42
6.1 Functions List	42
6.2 Basic Functions	43
6.2.1 Communication between master station and remote I/O stations	43
6.2.2 Communication between master station and remote device stations	45
6.2.3 Communication between master station and intelligent device stations	49
6.2.4 Communication in compound system	53
6.2.5 Network parameter setting with GX Works2	58
6.3 RAS Function	59
6.3.1 Slave station cutoff function	59
6.3.2 Automatic return function	59
6.3.3 Data link status setting against error in master station PLC	60
6.3.4 Setting of input data status from data link faulty station	61
6.3.5 Slave station refresh/compulsory clear setting in case of programmable controller CPU STOP	62
6.3.6 Consistency control function	63
6.4 Handy Functions	66
6.4.1 Remote device station initialization procedure registration function	66
6.4.2 Reserved station function	70
6.4.3 Error invalid station function	71
6.4.4 Temporary Error Invalid Station Specification Function	72
6.4.5 Data link stop/restart	74
6.4.6 Station number overlap check function	75
6.4.7 Increasing the number of cyclic points	76
6.4.8 Accessing the other station from CC-Link	79

7. Data Link Processing Time	80
7.1 Link Scan Time	80
7.2 Transmission Delay Time	82
7.2.1 Master station <-> Remote I/O station	82
7.2.2 Master station <-> Remote device station (Ver. 1 compatible slave station)	82
7.2.3 Master station <-> Remote device station (Ver. 2 compatible slave station)	83
7.2.4 Master station <-> Intelligent device station (Ver. 1 compatible slave station)	84
7.2.5 Master station <-> Intelligent device station (Ver. 2 compatible slave station)	85
7.3 Status of Each Station when an Error has Occurred	86
7.3.1 Status of master station and remote I/O station when an error has occurred	86
7.3.2 Status of remote device station and intelligent device station when an error has occurred	87

8. Parameter Setting	88
8.1 Procedure from Parameter Setting to Data Link Startup.....	88
8.1.1 Relationship between buffer memory and internal memory	88
8.1.2 Procedure from parameter settings to data link startup with buffer memory	88
8.1.3 Relationship between network parameter and internal memory	89
8.1.4 Procedure from parameter settings to data link startup with GX Works2.....	89
8.2 Parameter Setting Items	90
8.3 Parameter Setting from Sequence Program.....	91
8.4 Parameter Setting from GX Works2.....	93
8.4.1 Network parameter setting	93
8.4.2 Operation setting	94
8.4.3 Station Information Setting	95
8.5 Example of Parameter Setting	96
8.5.1 Example of system configuration.....	96
8.5.2 Example of program for parameter setting.....	96
8.5.3 Parameter setting using network parameters.....	98
9. Data Link Procedure	100
9.1 Data Link Procedure	101
9.2 Hardware Test (Master Block Status Check).....	102
9.3 Switch setting.....	103
9.3.1 Station number setting.....	103
9.3.2 Transmission rate setting, line test, hardware test, transmission speed test	104
9.4 Line Test (Connection Status Check)	105
9.4.1 Line test 1	105
9.4.2 Line test 2.....	106
9.5 Transmission Speed Test	107
10. Buffer Memory	108
10.1 How to read/write from/to buffer memory.....	108
10.1.1 FROM/TO instructions.....	108
10.1.2 Direct specification of buffer memory	108
10.2 Buffer Memory List.....	109
10.3 Parameter information area	110
10.3.1 [BFM#0] Mode setting	111
10.3.2 [BFM#1] Number of connected units.....	112
10.3.3 [BFM#2] Number of retries	112
10.3.4 [BFM#3] Number of automatic return units.....	112
10.3.5 [BFM#6] Operation specification when CPU is down	112
10.3.6 [BFM#12] Data link disorder station setting.....	113
10.3.7 [BFM#13] Case of CPU STOP setting.....	113
10.3.8 [BFM#16] Reserved station specification	113
10.3.9 [BFM#20] Error invalid station specification	114
10.3.10 [BFM#32 to #47] Station information.....	115
10.4 I/O signals to PLC	116
10.4.1 [BFM#10] Input signal details	118
10.4.2 [BFM#10] Output signal.....	120
10.4.3 [BFM#14] Output signal monitor.....	120
10.5 Master Block Control Signals	121
10.5.1 [BFM#29] Error code	121
10.5.2 [BFM#30] FX Series model code.....	122
10.6 [BFM#220 to #223] Consistency control	122
10.7 [BFM#224 to #255] Remote Input (RX).....	123
10.8 [BFM#352 to #383] Remote Output (RY).....	125
10.9 [BFM#480 to #543] Remote registers (RWw).....	127

10.10 [BFM#736 to #799] Remote registers (RWr).....	129
10.11 [BFM#992 to #1503] Slave Station Offset, Size Information.....	131
10.12 Link special relay/Link special register (SB/SW).....	134
10.12.1 [BFM#1504 to #1535] Link special relay (SB).....	134
10.12.2 [BFM#1536 to #2047] Link special register (SW).....	137
10.13 [BFM#16384 to #16415] Ver. 2 Compatible Remote Input (RX).....	143
10.14 [BFM#16896 to #16927] Ver. 2 Compatible Remote Output (RY).....	144
10.15 [BFM#17408 to #17503] Ver. 2 Compatible Remote Registers (RWw).....	145
10.16 [BFM#19456 to #19551] Ver. 2 Compatible Remote Registers (RWr).....	146

11. Programming **147**

11.1 Precautions in Programming.....	147
11.2 Link Special Relay (SB)/Link Special Register (SW).....	149
11.2.1 Link special relay (SB).....	149
11.2.2 Link special register (SW).....	149
11.2.3 Update timing of the link special registers.....	150

12. Example of Communication between Master Station and Remote I/O Stations **151**

12.1 System Configuration.....	151
12.1.1 Setting of master station.....	151
12.1.2 Setting of remote I/O station.....	152
12.1.3 Setting of parameters.....	153
12.1.4 Creating a program for communication.....	155
12.1.5 Execution of data link.....	157

13. Example of Communication between Master Station and Remote Device Stations **159**

13.1 When Remote Net Ver. 1 Mode is Used.....	159
13.1.1 System configuration.....	159
13.1.2 Setting of master station.....	159
13.1.3 Setting of remote device station.....	160
13.1.4 Setting of parameters.....	161
13.1.5 Creating a program for communication.....	163
13.1.6 Execution of data link.....	167
13.1.7 Confirmation of operation by LED indication.....	167
13.1.8 Confirmation of operation by program.....	168
13.2 When Remote Net Ver. 2 Mode is Used.....	169
13.2.1 System configuration.....	169
13.2.2 Setting of master station.....	169
13.2.3 Setting of remote device station.....	170
13.2.4 Setting of parameters.....	171
13.2.5 Creating a program for communication.....	173
13.2.6 Execution of data link.....	177
13.2.7 Confirmation of operation by LED indication.....	177
13.2.8 Confirmation of operation by program.....	178
13.3 When Remote Net Additional Mode is Used.....	179
13.3.1 System configuration.....	179
13.3.2 Setting of master station.....	179
13.3.3 Setting of remote device station.....	180
13.3.4 Setting of parameters.....	181
13.3.5 Creating a program for communication.....	183
13.3.6 Execution of data link.....	187
13.3.7 Confirmation of operation by LED indication.....	187
13.3.8 Confirmation of operation by program.....	188

14. Example of Communication between Master Station and Intelligent Device Stations **189**

14.1 When Remote Net Ver. 1 Mode is Used	189
14.1.1 System configuration	189
14.1.2 Setting of master station	189
14.1.3 Setting of intelligent device station	190
14.1.4 Setting of parameters	191
14.1.5 Creating a program for communication	193
14.1.6 Execution of data link	197
14.1.7 Confirmation of operation by LED indication	197
14.1.8 Confirmation of operation by program	198
14.2 When Remote Net Ver. 2 Mode is Used	199
14.2.1 System configuration	199
14.2.2 Setting of master station	199
14.2.3 Setting of intelligent device station	200
14.2.4 Setting of parameters	201
14.2.5 Creating a program for communication	203
14.2.6 Execution of data link	207
14.2.7 Confirmation of operation by LED indication	207
14.2.8 Confirmation of operation by program	208
14.3 When Remote Net Additional Mode is Used	209
14.3.1 System configuration	209
14.3.2 Setting of master station	209
14.3.3 Setting of intelligent device station	210
14.3.4 Setting of parameters	211
14.3.5 Creating a program for communication	213
14.3.6 Execution of data link	217
14.3.7 Confirmation of operation by LED indication	217
14.3.8 Confirmation of operation by program	218

15. Example of Communication in Compound System **219**

15.1 When Remote Net Ver. 1 Mode is Used	219
15.1.1 System configuration	219
15.1.2 Setting of master station	219
15.1.3 Setting of remote I/O station	220
15.1.4 Setting of remote device station	220
15.1.5 Setting of intelligent device station	220
15.1.6 Setting of parameters	221
15.1.7 Creating a program for communication	223
15.1.8 Execution of data link	227
15.1.9 Confirmation of operation by LED indication	227
15.1.10 Confirmation of operation by program	228
15.2 When Remote Net Ver. 2 Mode is Used	229
15.2.1 System configuration	229
15.2.2 Setting of master station	229
15.2.3 Setting of remote I/O station	230
15.2.4 Setting of remote device station	230
15.2.5 Setting of intelligent device station	230
15.2.6 Setting of parameters	231
15.2.7 Creating a program for communication	233
15.2.8 Execution of data link	237
15.2.9 Confirmation of operation by LED indication	237
15.2.10 Confirmation of operation by program	238

15.3 When Remote Net Additional Mode is Used.....	239
15.3.1 System configuration	239
15.3.2 Setting of master station.....	239
15.3.3 Setting of remote I/O station.....	240
15.3.4 Setting of remote device station	240
15.3.5 Setting of intelligent device station	240
15.3.6 Setting of parameters	241
15.3.7 Creating a program for communication	243
15.3.8 Execution of data link	247
15.3.9 Confirmation of operation by LED indication	247
15.3.10 Confirmation of operation by program	248

16. Troubleshooting	249
----------------------------	------------

16.1 Troubleshooting procedure	250
16.2 Troubleshooting when ERR. LED is Flashing in Master Station	257
16.3 Troubleshooting by Error Code	259
16.4 CC-Link Diagnostics.....	262
16.4.1 Host monitoring/Other station monitoring	262
16.4.2 Loop test/Obtain transmission speed setting.....	263
16.4.3 Creating a check sheet.....	265
16.4.4 Starting/stopping data link	267
16.4.5 Setting/canceling temporary error invalid station.....	267

Appendix A: Version Information	269
--	------------

Appendix A-1 Version Information	269
Appendix A-1-1 Version check method	269
Appendix A-1-2 Version upgrade history	269

Appendix B: Setting Sheet	270
----------------------------------	------------

Appendix B-1 Parameter setting sheet	270
Appendix B-2 Station information setting sheet	271

Appendix C: Differences with FX2N-16CCL-M	273
--	------------

Appendix C-1 Differences with FX2N-16CCL-M	273
--	-----

Warranty.....	275
----------------------	------------

Revised History	276
------------------------------	------------

Standards

Certification of UL, cUL standards

FX3U-16CCL-M units comply with the UL standards (UL, cUL).

UL, cUL File number :E95239

Regarding the standards that comply with the main unit, please refer to either the FX series product catalog or consult with your nearest Mitsubishi product provider.

Compliance with EC directive (CE Marking)

This document does not guarantee that a mechanical system including this product will comply with the following standards.

Compliance to EMC directive and LVD directive for the entire mechanical module should be checked by the user / manufacturer. For more information please consult with your nearest Mitsubishi product provider.

Regarding the standards that comply with the main unit, please refer to either the FX series product catalog or consult with your nearest Mitsubishi product provider.

Requirement for Compliance with EMC directive

The following products have shown compliance through direct testing (of the identified standards below) and design analysis (through the creation of a technical construction file) to the European Directive for Electromagnetic Compatibility (2004/108/EC) when used as directed by the appropriate documentation.

Attention

- This product is designed for use in industrial applications.

Note

- Manufactured by:
Mitsubishi Electric Corporation
2-7-3 Marunouchi, Chiyoda-ku, Tokyo, 100-8310 Japan
- Manufactured at:
Mitsubishi Electric Corporation Himeji Works
840 Chiyoda-machi, Himeji, Hyogo, 670-8677 Japan
- Authorized Representative in the European Community:
Mitsubishi Electric Europe B.V.
Gothaer Str. 8, 40880 Ratingen, Germany

Type: Programmable Controller (Open Type Equipment)
 Models: MELSEC FX3U series manufactured
 from August 1st, 2011 FX3U-16CCL-M

Standard	Remark
EN61131-2:2007 Programmable controllers - Equipment requirements and tests	Compliance with all relevant aspects of the standard. EMI • Radiated Emission • Conducted Emission EMS • Radiated electromagnetic field • Fast transient burst • Electrostatic discharge • High-energy surge • Voltage drops and interruptions • Conducted RF • Power frequency magnetic field

Caution to conform with EC Directives

- Installation in Enclosure
 Programmable logic controllers are open-type devices that must be installed and used within conductive control cabinets. Please use the programmable logic controller while installed within a conductive shielded control cabinet. Please secure the cabinet door to the control cabinet (for conduction). Installation within a control cabinet greatly affects the safety of the system and aids in shielding noise from the programmable logic controller.
- Control cabinet
 - The control cabinet must be conductive.
 - Ground the control cabinet with the thickest possible grounding cable.
 - To ensure that there is electric contact between the control cabinet and its door, connect the cabinet and its doors with thick wires.
 - In order to suppress the leakage of radio waves, the control cabinet structure must have minimal openings. Also, wrap the cable holes with a shielding cover or other shielding devices.
 - The gap between the control cabinet and its door must be as small as possible by attaching EMI gaskets between them.

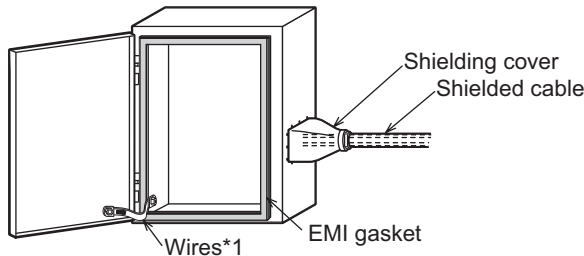

*1. These wires are used to improve the conductivity between the door and control cabinet.

- Configuration example inside control cabinet

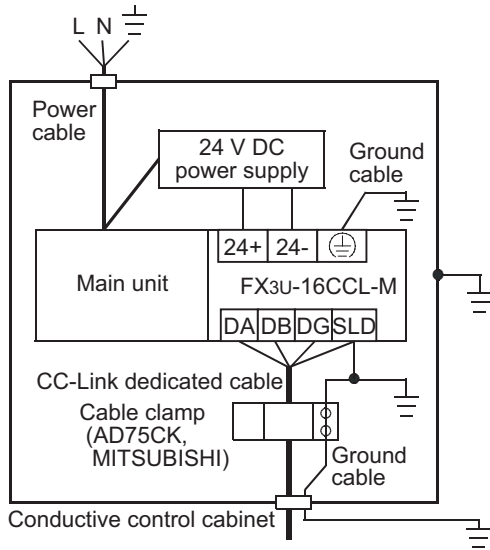

- Wiring simplified diagram

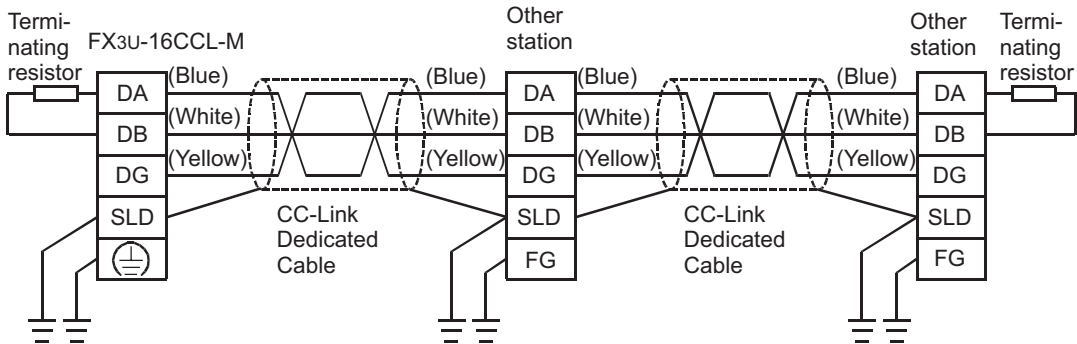

- Notes for compliance with EN61131-2:2007

General notes on the use of the power supply cable.

- The FX3U-16CCL-M unit requires that the cable used for power supply is 30 m or less.
- When the cable used for power supply exceeds 30 m, a noise filter (Ex. TDK-Lambda MBS1205-22 or similar) should be placed on the 24 V DC power cabling as close (within 500 mm) to the FX3U-16CCL-M termination points as possible, refer to following figure.

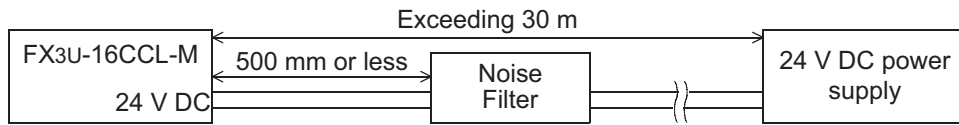

Associated Manuals

Only the installation manual is packed together with the FX3U-16CCL-M CC-Link master block.
For a detailed explanation of the FX3U-16CCL-M CC-Link master block, refer to this manual.
For the hardware information and instructions on the PLC main unit, refer to the respective manuals.

- Refer to these manuals
- ✓ Refer to the appropriate equipment manual
- △ For a detailed explanation, refer to an additional manual

		Title of manual	Document number	Description	Model code
Manual for the Main Unit					
FX3G Series PLCs Main Unit					
△	Supplied Manual	FX3G Series Hardware Manual	JY997D33401	Describes FX3G Series PLC specification for I/O, wiring and installation extracted from the FX3G User's Manual - Hardware Edition. For details, refer to FX3G Series User's Manual - Hardware Edition.	-
○	Additional Manual	FX3G Series User's Manual - Hardware Edition	JY997D31301	Describes FX3G Series PLC specification details for I/O, wiring, installation and maintenance.	09R521
FX3U Series PLCs Main Unit					
△	Supplied Manual	FX3U Series Hardware Manual	JY997D18801	Describes FX3U Series PLC specification for I/O, wiring and installation extracted from the FX3U User's Manual - Hardware Edition. For details, refer to FX3U Series User's Manual - Hardware Edition.	-
○	Additional Manual	FX3U Series User's Manual - Hardware Edition	JY997D16501	Describes FX3U Series PLC specification details for I/O, wiring, installation and maintenance.	09R516
FX3GC Series PLCs Main Unit					
△	Supplied Manual	FX3GC Series Hardware Manual	JY997D45201	Describes FX3GC Series PLC specification for I/O, wiring and installation extracted from the FX3GC User's Manual - Hardware Edition. For details, refer to FX3GC Series User's Manual - Hardware Edition.	-
○	Additional Manual	FX3GC Series User's Manual - Hardware Edition	JY997D45401	Describes FX3GC Series PLC specification details for I/O, wiring, installation and maintenance.	09R533
FX3UC Series PLCs Main Unit					
△	Supplied Manual	FX3UC(D,DS,DSS) Series Hardware Manual	JY997D28601	Describes FX3UC(D,DS,DSS) Series PLC specification for I/O, wiring and installation extracted from the FX3UC Series User's Manual - Hardware Edition. For details, refer to FX3UC Series User's Manual - Hardware Edition.	-
△	Supplied Manual	FX3UC-32MT-LT-2 Hardware Manual	JY997D31601	Describes FX3UC-32MT-LT-2 specification for I/O, wiring and installation extracted from the FX3UC User's Manual - Hardware Edition. For details, refer to FX3UC Series User's Manual - Hardware Edition.	-
△	Supplied Manual	FX3UC-32MT-LT Hardware Manual (Only Japanese document)	JY997D12701	Describes FX3UC-32MT-LT specification for I/O, wiring and installation extracted from the FX3UC User's Manual - Hardware Edition. For details, refer to FX3UC Series User's Manual - Hardware Edition.	-
○	Additional Manual	FX3UC Series User's Manual - Hardware Edition	JY997D28701	Describes FX3UC Series PLC specification details for I/O, wiring, installation and maintenance.	09R519
Programming					
○	Additional Manual	FX3G/FX3U/FX3GC/FX3UC Series Programming Manual - Basic & Applied Instruction Edition	JY997D16601	Describes FX3G/FX3U/FX3GC/FX3UC Series PLC programming for basic/applied instructions and devices.	09R517

		Title of manual	Document number	Description	Model code
✓	Additional Manual	MELSEC-Q/L/F Structured Programming Manual (Fundamentals)	SH-080782	Programming methods, specifications, functions, etc. required to create structured programs.	13JW06
✓	Additional Manual	FX CPU Structured Programming Manual [Device & Common]	JY997D26001	Devices, parameters, etc. provided in structured projects of GX Works2.	09R925
✓	Additional Manual	FX CPU Structured Programming Manual [Basic & Applied Instruction]	JY997D34701	Sequence instructions provided in structured projects of GX Works2.	09R926
✓	Additional Manual	FX CPU Structured Programming Manual [Application Functions]	JY997D34801	Application functions provided in structured projects of GX Works2.	09R927
Manuals for FX3U-16CCL-M CC-Link master block					
△	Supplied Manual	FX3U-16CCL-M Installation Manual	JY997D43401	Describes installation specifications for the FX3U-16CCL-M CC-Link master block extracted from the FX3U-16CCL-M User's Manual. For details, refer to FX3U-16CCL-M User's Manual.	-
⊙	Additional Manual	FX3U-16CCL-M User's Manual (This Manual)	JY997D43601	Describes details of the FX3U-16CCL-M CC-Link master block.	09R724
Manuals for FX3U-64CCL CC-Link Interface block					
△	Supplied Manual	FX3U-64CCL Installation Manual	JY997D29801	Describes installation specifications for the FX3U-64CCL CC-Link interface block extracted from the FX3U-64CCL User's Manual. For details, refer to FX3U-64CCL User's Manual.	-
⊙	Additional Manual	FX3U-64CCL User's Manual	JY997D30401	Describes FX3U-64CCL CC-Link interface block details.	09R718

Generic Names and Abbreviations Used in the Manual

Generic name or abbreviation	Description
PLC	
FX3G series	Generic name for FX3G Series PLC
FX3G PLC or main unit	Generic name for FX3G Series PLC main unit
FX3U series	Generic name for FX3U Series PLC
FX3U PLC or main unit	Generic name for FX3U Series PLC main unit
FX3GC series	Generic name for FX3GC Series PLC
FX3GC PLC or main unit	Generic name for FX3GC Series PLC main unit
FX3UC series	Generic name for FX3UC Series PLC
FX3UC PLC or main unit	Generic name for FX3UC Series PLC main unit
Expansion board	Generic name for expansion board The number of connectable units, however, depends on the type of main unit. To check the number of connectable units, refer to the User's Manual - Hardware Edition of the main unit to be used for your system.
Special adapter	Generic name for high-speed input/output special adapter, communication special adapter, analog special adapter, and CF card special adapter. The number of connectable units, however, depends on the type of main unit. To check the number of connectable units, refer to the User's Manual - Hardware Edition of the main unit to be used for your system.
I/O extension unit/block	Generic name for input/output powered extension unit and input/output extension block The number of connectable units, however, depends on the type of main unit. To check the number of connectable units, refer to the User's Manual - Hardware Edition of the main unit to be used for your system.
Special function unit/block or Special extension unit	Generic name for special function unit and special function block The number of connectable units, however, depends on the type of main unit. To check the number of connectable units, refer to the User's Manual - Hardware Edition of the main unit to be used for your system.
Special function unit	Generic name for special function unit
Special function block	Generic name for special function block
FX3U-16CCL-M or master block	Abbreviated name for FX3U-16CCL-M
Memory cassette	Generic name for memory cassette. The number of connectable units, however, depends on the type of main unit. To check the number of connectable units, refer to the User's Manual - Hardware Edition of the main unit to be used for your system.
Battery	Abbreviated name for FX3U-32BL
FX Series terminal block	Generic name for FX Series terminal block. The number of connectable units, however, depends on the type of main unit. To check the number of connectable units, refer to the User's Manual - Hardware Edition of the main unit to be used for your system.
Cyclic transmission	Transmission method by which data of remote I/O and remote registers are refreshed periodically.
Transient transmission	Transmission method by which 1:1 communication can be performed with the target specified and at any timing.
Master station	Station which controls the data link system. One master station is required in one system.
Local station	Station having a programmable controller CPU and the ability to communicate with the master and other local stations.
Remote I/O station	Remote station that handles bit data only. (Performs input and output with external devices.)
Remote device station	Remote station that handles bit and word data. (Performs input and output with external devices, and analog data conversion.)
Remote station	General name for remote I/O station and remote device station. Controlled by the master station.
Intelligent device station	Generic term for the stations that can perform transient transmission, such as the FX3U-64CCL.
Standby master station	Backup station for data link control when the link to the master station is disconnected due to a programmable controller CPU or power supply problem.
Slave station	General name for remote I/O station, remote device station, and intelligent device station.
Remote net ver. 1 mode	Mode in which compatibility with the conventional unit (FX2N-16CCL-M) is achieved. Select this mode when the number of cyclic points need not be increased or when the FX2N-16CCL-M is used to replace the conventional unit as a maintenance product.

Generic name or abbreviation	Description
Remote net ver. 2 mode	Select this mode when increasing the number of cyclic points and configuring a new system.
Remote net additional mode	Select this mode when adding a Ver. 2 compatible station to the existing system to increase the number of cyclic points.
Ver. 1 compatible slave station	Slave station compatible with the remote net Ver. 1 mode.
Ver. 2 compatible slave station	Slave station compatible with the remote net Ver. 2 mode.
SB	Link special relay (for CC-Link). 1-bit information which indicates the operation status and the data link status of the master station.
SW	Link special register (for CC-Link). 16-bit information which indicates the operation status and the data link status of the master station.
RX	Remote input (for CC-Link) 1-bit information input from a slave station to the master station.
RY	Remote output (for CC-Link) 1-bit information output from the master station to a slave station.
RWw	Remote register (write area for CC-Link) 16-bit information output from the master station to a slave station.
RWr	Remote register (read area for CC-Link) 16-bit information input from a slave station to the master station.
Peripheral unit	
Peripheral unit	Generic name for programming software, handy programming panel, and indicator
Programming tool	
Programming tool	Generic name for programming software and handy programming panel
Programming software	Generic name for programming software
GX Works2	Abbreviation of programming software packages SW□DNC-GXW2-J/SW□DNC-GXW2-E
GX Developer	Abbreviation of programming software packages SW□D5C-GPPW-J/SW□D5C-GPPW-E
Handy programming panel (HPP)	Generic name for FX-30P and FX-20P(-E)
Indicator	
GOT1000 series	Generic name for GT15, GT11 and GT10
GOT-900 series	Generic name for GOT-A900 series and GOT-F900 series
GOT-A900 series	Generic name for GOT-A900 series
GOT-F900 series	Generic name for GOT-F900 series
ET-940 series	Generic name for ET-940 series Only manuals in Japanese are available for these products
Manual	
FX3G Hardware Edition	Abbreviation of FX3G Series User's Manual - Hardware Edition
FX3U Hardware Edition	Abbreviation of FX3U Series User's Manual - Hardware Edition
FX3GC Hardware Edition	Abbreviation of FX3GC Series User's Manual - Hardware Edition
FX3UC Hardware Edition	Abbreviation of FX3UC Series User's Manual - Hardware Edition
Programming manual	Abbreviation of FX3G/FX3U/FX3GC/FX3UC Series Programming Manual - Basic and Applied Instruction Edition
Communication control Edition	Abbreviation of FX Series User's Manual - Data Communication Edition
Analog control Edition	Abbreviation of FX3G/FX3U/FX3GC/FX3UC Series User's Manual - Analog Control Edition
Positioning control Edition	Abbreviation of FX3G/FX3U/FX3GC/FX3UC Series User's Manual - Positioning Control Edition

Reading the Manual

In this manual, the following formats are used for describing the common items.

- Shows the manual title.**
This area shows the manual title for the current page.
- Shows the title of the chapter and the title of the section.**
This area shows the title of the chapter and the title of the section for the current page.
- Indexes the chapter number.**
The right side of each page indexes the chapter number for the page currently opened.

FX3U-16CCL-M User's Manual
3 System Configuration
3.6 CC-Link Version

3.6 CC-Link Version

There are two different CC-Link versions: Ver. 1 and Ver. 2.

1. Definitions of Ver. 1.00 and Ver. 1.10
Ver. 1.10 is a version in which the station-to-station cable length was improved to 20 cm or more. In contrast, the older version is defined as Ver. 1.00. The station-to-station cable length must be 20 cm or more when the following conditions are met:

- All the modules that compose the CC-Link system are Ver. 1.10 units.
- All the data link cables are CC-Link Ver. 1.10 compatible cables.

→ For the maximum overall cable length for Ver. 1.10, refer to Subsection 2.5.2.

2. Definition of Ver. 2
Units supporting the extended cyclic transmission are defined as the Ver. 2 compatible units. Note that the specifications of the cable remain the same as Ver. 1.10.

Caution
The specifications for Version 1.00 must be applied to the maximum cable overall length and station-to-station cable length if a system contains all of Ver. 1.00, Ver. 1.10, and Ver. 2 compatible units.

→ For the maximum overall cable length and station-to-station cable length of Ver. 1.00, refer to Subsection 2.5.1.

1 Introduction

2 Specification

3 System Configuration

4 Installation

5 Wiring

6 Introduction of Functions

7 Data Link Processing Time

8 Parameter Setting

9 Data Link Procedure

10 Buffer Memory

31

Shows the reference.
The "→" mark indicates a reference destination and reference manual.

The above is different from the actual page, as it is provided for explanation only.

1. Introduction

1.1 Outline

1.1.1 Outline of CC-Link System

The CC-Link system connects distributed I/O units, intelligent function units, special function units, etc. with dedicated cables, and controls such modules from the PLC.

- By distributing each module to facility equipment such as conveyor lines and machines, necessary wiring can be reduced.
- Simple, high speed communication can be accomplished with modules that handle simple ON/OFF data such as I/Os or numerical data.
- Connections can be made to different types of devices made by partner manufacturers, giving flexibility to the system.

1.1.2 Outline of CC-Link Master Block FX3U-16CCL-M

The CC-Link master block FX3U-16CCL-M is a special function block which assigns an FX3G/FX3U/FX3GC/FX3UC Series PLC as the master station of a CC-Link system.

Only one FX3U-16CCL-M unit can be connected to a single programmable logic controller main unit.

- Compatible with CC-Link Ver. 2.00 and Ver. 1.10
The FX3U-16CCL-M is compatible with CC-Link Ver. 2.00, and enables expanded cyclic transmission to facilitate the handling of applications requiring multiple points of data processing.
In addition to Ver. 2.00, Ver. 1.10 is also supported by the FX3U-16CCL-M.
- The FX3U-16CCL-M supports connection of intelligent device stations
Remote I/O stations, remote device stations and intelligent device station can be also connected to the FX3U-16CCL-M.

Caution

Local stations can not be connected.

- The FX3U-16CCL-M supports the setting of network parameters.
The operator can set network parameters for CC-Link using GX Works2. As a result, sequence programs for setting CC-Link parameters are not required.
Refer to Section 3.2 for applicable PLCs and applicable GX Works2 versions.
- The FX3U-16CCL-M supports the remote device station initialization procedure registration function.
The operator can initialize remote device stations using GX Works2. As a result, sequence programs for initializing remote device stations are not required.
Refer to Section 3.2 for applicable PLCs and applicable GX Works2 versions.
- The FX3U-16CCL-M supports the other station access function from CC-Link.
The operator can execute program writing, program reading, program verification and device batch monitoring to the main unit connected to a FX3U-64CCL from CC-Link using GX Works2.
Refer to Section 3.2 for applicable PLCs and applicable GX Works2 versions.

1

Introduction

2

Specification

3

System Configuration

4

Installation

5

Wiring

6

Introduction of Functions

7

Data Link Processing Time

8

Parameter Setting

9

Data Link Procedure

10

Buffer Memory

- By using the CC-Link interface blocks FX2N-32CCL or FX3U-64CCL, two or more FX Series PLCs can be connected as intelligent device station or remote device stations to create a simple distributed system.

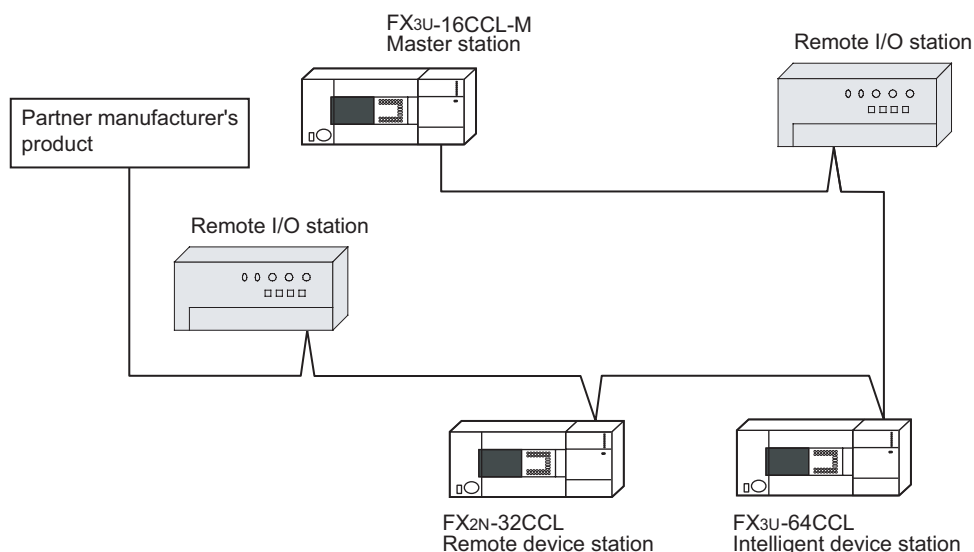

- Master station : Station which controls the data link system
- Remote I/O station : Remote station which handles only the 1-bit information
- Remote device station : Remote station which handles both bit information and word information
- Intelligent device station : Stations that can perform transient transmission

1.2 External Dimensions and Part Names

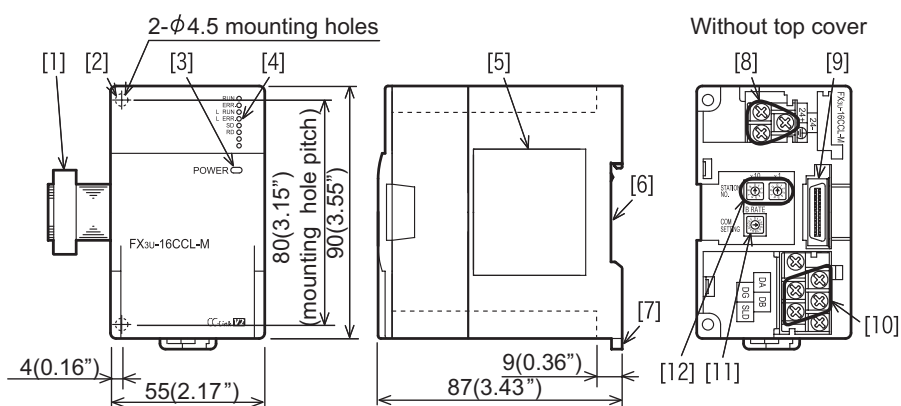

Unit : mm (inches)

MASS (Weight) : 0.3 kg (0.66 lbs)

Accessories : Label for indication of special function unit/block number,

Dust proof protection sheet,

Manual supplied with product,

Terminal resistor

- For CC-Link dedicated cable
110 Ω 1/2 W (color cable: brown, brown and brown) × 2 cables
- For CC-Link dedicated high-performance cable
130 Ω 1/2 W (color cable: brown, orange and brown) × 2 cables

- | | |
|---|--|
| [1] Extension cable | [7] DIN rail mounting hook |
| [2] Direct mounting hole: 2 holes of φ4.5 (0.18")
(mounting screw: M4 screw) | [8] Power supply terminal block |
| [3] Power LED (green) | [9] Extension connector |
| [4] Status LEDs | [10] CC-Link connection terminal block |
- Refer to Section 1.4
- | | |
|---|---------------------------------------|
| [5] Name plate | [11] Transmission rate setting switch |
| [6] DIN rail mounting groove (DIN rail: DIN46277,
35 mm (1.38") width) | [12] Station number setting switch |

1.3 Terminal Layout

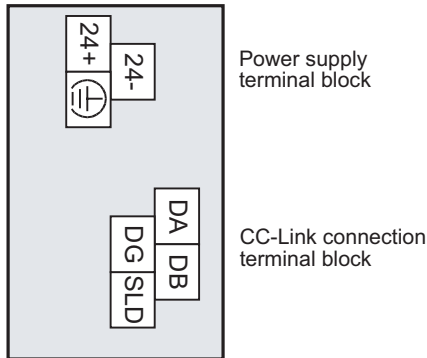

Terminal name	Description
24+	24 V DC power supply, + side
24-	24 V DC power supply, - side
⊕	Ground terminal (Functional ground)
DA	Send/receive data
DB	Send/receive data
DG	Data ground
SLD	Shield

- Terminal screw and terminal block mounting screw size, and tightening torque

Terminal name	Terminal screw size	Tightening torque
Power supply terminal block, CC-Link connection terminal block	M3 screw	0.42 to 0.58 N•m
CC-Link connection terminal block mounting screw (black)	M3.5 screw	0.66 to 0.91 N•m

Caution

CC-Link connection terminal block can be detached or attached. Make sure to cut off all phases of the power supply externally.

1.4 Power and Status LEDs

LED display	LED Color	Status	Description
POWER	Green	OFF	Power is not being supplied from the external power supply (24 V DC).
		ON	Power is being supplied from the external power supply (24 V DC).
RUN	Green	OFF	FX3U-16CCL-M has failed.
		ON	Under FX3U-16CCL-M normal operation.
ERR.	Red	OFF	No errors.
		Flicker	Communication error has occurred in some stations.
		ON	Communication error has occurred in all stations, error in the settings, error in the parameter details, error with the communication, error with the H/W.
L RUN	Green	OFF	Offline.
		ON	Data link is being executed (host station).
L ERR.	Red	OFF	No communication error.
		Flicker	The switch setting was changed after start. There is no terminating resistor. Influence from noise.
		ON	There is a data linking error (host station). There is a setting error.
SD	Green	OFF	Data is not being sent.
		ON	Data is being sent.
RD	Green	OFF	Data is not being received.
		ON	Data is being received.

1 Introduction

2 Specification

3 System Configuration

4 Installation

5 Wiring

6 Introduction of Functions

7 Data Link Processing Time

8 Parameter Setting

9 Data Link Procedure

10 Buffer Memory

2. Specification

DESIGN PRECAUTIONS



DANGER

- When executing control (data changes) to an operating PLC, construct an interlock circuit in the sequence program so that the entire system operates conservatively.
In addition, when executing control such as program changes and operation status changes (status control) to an operating PLC, thoroughly read the manual and sufficiently confirm safety in advance.
Especially in control from external equipment to a PLC in a remote place, problems in the PLC may not be able to be handled promptly due to abnormality in data transfer.
Construct an interlock circuit in the sequence program. At the same time, determine the actions in the system between the external equipment and the PLC for protection against abnormalities in data transfer.
- Make sure to include the following safety circuits outside the PLC to ensure safe system operation even during external power supply problems or PLC failure.
Otherwise, malfunctions may cause serious accidents.
 - 1) Above all, the following components should be included: an emergency stop circuit, a protection circuit, an interlock circuit for opposite movements (such as normal vs. reverse rotation), and an interlock circuit (to prevent damage to the equipment at the upper and lower positioning limits).
 - 2) Note that when the PLC main unit detects an error during self diagnosis, such as a watchdog timer error, all outputs are turned off. Also, when an error that cannot be detected by the PLC main unit occurs in an input/ output control block, output control may be disabled.
External circuits and mechanisms should be designed to ensure safe machinery operation in such cases.

DESIGN PRECAUTIONS

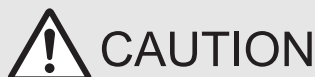

CAUTION

- Observe the following items. Failure to do so may cause incorrect data-writing through noise to the PLC and result in PLC failure, machine damage or other accident.
 - 1) Do not bundle the control line together with or lay it close to the main circuit or power line. As a guideline, lay the control line at least 100mm (3.94") or more away from the main circuit or power line.
Noise may cause malfunctions.
 - 2) Ground the shield wire or shield of a shielded cable. Do not use common grounding with heavy electrical systems
- Do not apply excessive pressure to the power supply terminal block or CC-Link connection terminal block.
Excessive pressure may cause damage or error.

DISPOSAL PRECAUTIONS

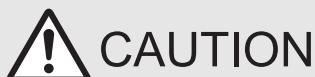

CAUTION

- Please contact a certified electronic waste disposal company for the environmentally safe recycling and disposal of your device.

TRANSPORTATION AND STORAGE PRECAUTIONS

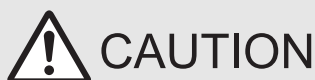

CAUTION

- The PLC is a precision instrument. During transportation, avoid impacts larger than those specified in the general specifications of the PLC main unit manual.
Failure to do so may cause failures in the PLC.
After transportation, verify the operations of the PLC.

2.1 General Specifications

For items not listed below, specifications are the same as the of the PLC main unit.
For general specifications, refer to the manual of the PLC main unit.

- Refer to FX3G Hardware Edition.
- Refer to FX3U Hardware Edition.
- Refer to FX3Gc Hardware Edition.
- Refer to FX3Uc Hardware Edition.

Item	Specification	
Dielectric withstand voltage	500 V AC for one minute	Between all terminals and ground terminal
Insulation resistance	5 MΩ or more by 500 V DC Megger	

2.2 Power Supply Specifications

Item		Specification
External power supply	Power supply voltage	24 V DC +20% -15% Ripple (p-p) within 5%
	Permitted instantaneous power failure time	Operation continues when the instantaneous power failure is shorter than PS1:1ms.
	Current consumption	240 mA
Internal power supply	Power supply voltage	5 V DC of PLC is not used. (5 V DC is converted from 24 V DC external power supply.)
	Current consumption	Make sure to observe the power-on timing and the procedure.

2.3 Performance Specification

Item	Specification
Applicable function	Master station function (The local station and standby master station functions are not provided.)
CC-Link applicable version	Ver. 2.00 (Ver. 1.10 also supported.)
Station number	0 (set by rotary switch)
Transmission rate	156 Kbps/625 Kbps/2.5 Mbps/5 Mbps/10 Mbps (set by rotary switch)
Maximum total cable length (maximum transmission distance)	1,200 m maximum (varies depending on the transmission speed.) For details, refer to Section 2.5.
Maximum number of connectable stations	1) Remote I/O stations: 8 maximum (Each station occupies 32 I/O points of the PLC.) 2) Remote device stations + Intelligent device stations: 8 maximum (The total number of RX/RX points is 256 or less.)
Maximum number of I/O points per system	When using an FX3U/FX3UC PLC 1)+2) total number of points ≤ 384 points 1) (Actual number of PLC I/O points) + (Number of points occupied by special function blocks) + (Number of points occupied by the FX3U-16CCL-M: 8 points) ≤ 256 points 2) 32 × Number of remote I/O stations ≤ 256 points When using an FX3G/FX3GC PLC 32 × Number of remote I/O stations ≤ 128 points
Number of link points per station ^{*1}	Remote I/O (RX, RY): 32 points Remote register (RWw): 4 points (Master station → Remote device station/intelligent device station) Remote register (RWr): 4 points (Remote device station/intelligent device station) → Master station)
Communication method	Broadcast polling system
Synchronous method	Frame synchronization method
Encoding method	NRZI method
Transmission path type	Bus (RS-485)
Transmission format	Conforms to HDLC
Error control method	CRC($X^{16}+X^{12}+X^5+1$)
Connection cable	CC-Link dedicated cable/CC-Link dedicated high-performance cable/Ver. 1.10 compatible CC-Link dedicated cable ^{*2}
RAS function	<ul style="list-style-type: none"> • Automatic return function • Slave station cut-off function • Error detection by link special relay/register

Item	Specification
Communication with PLC	By FROM and TO instructions or direct specification of buffer memory (FX3U/FX3UC) via the buffer memory*3
Number of I/O occupied points	8 points
Number of connectable units to the main unit	1 (An FX3U-16CCL-M cannot be attached to main unit with an FX2N-16CCL-M and/or FX2N-32ASI-M.)

- *1. Indicates the number of link points for remote net ver.1 mode. For the number of link points for remote net ver.2 mode/remote net additional mode, refer to the following table.
- *2. CC-Link dedicated cables, Ver. 1.10 compatible CC-Link dedicated cable and CC-Link dedicated high-performance cable cannot be used together. Also attach the terminating resistor which matches the kind of the cable.
- *3. For details of other applied instructions and methods, refer to the FX3G/FX3U/FX3GC/FX3UC Programming Manual.

- Link points of remote net ver. 2 mode and remote net additional mode

CC-Link Version		CC-Link Ver. 1.10	CC-Link Ver. 2.00			
Expanded cyclic setting		-	Single	Double	Quadruple	Octuple
Occupies 1 station	bit (RX)	32 points	32 points	32 points	64 points	128 points
	bit (RY)	32 points	32 points	32 points	64 points	128 points
	word (RWw)	4 points	4 points	8 points	16 points	32 points
	word (RWr)	4 points	4 points	8 points	16 points	32 points
Occupies 2 stations	bit (RX)	64 points	64 points	96 points	192 points	-
	bit (RY)	64 points	64 points	96 points	192 points	
	word (RWw)	8 points	8 points	16 points	32 points	
	word (RWr)	8 points	8 points	16 points	32 points	
Occupies 3 stations	bit (RX)	96 points	96 points	160 points	-	-
	bit (RY)	96 points	96 points	160 points		
	word (RWw)	12 points	12 points	24 points		
	word (RWr)	12 points	12 points	24 points		
Occupies 4 stations	bit (RX)	128 points	128 points	224 points	-	-
	bit (RY)	128 points	128 points	224 points		
	word (RWw)	16 points	16 points	32 points		
	word (RWr)	16 points	16 points	32 points		

2.4 Communication Specification

2.4.1 Data transfer between master station and slave station

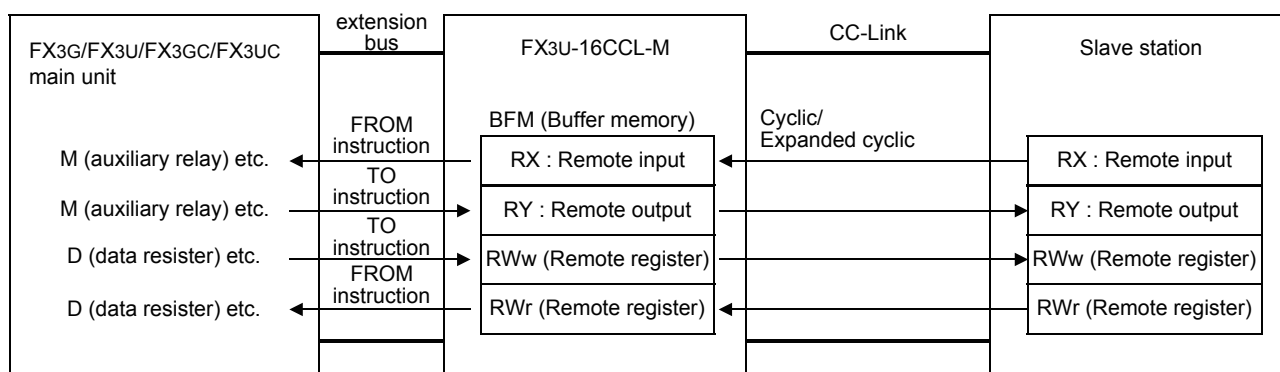

Data is transferred using FROM/TO instructions via the buffer memory (or direct specification of buffer memory) between the FX3G/FX3U/FX3GC/FX3UC PLC and the FX3U-16CCL-M. Data is replaced with internal devices (such as M, R and D), and used in sequence programs.

Cyclic transmission and extended cyclic transmission are available between the slave station and the FX3U-16CCL-M.

2.5 Maximum Transmission Distance

2.5.1 Maximum transmission distance (for Ver. 1.00)

This subsection describes the relationship between the transmission speed and the maximum transmission distance.

1. In the system consisting of only remote I/O stations and remote device stations

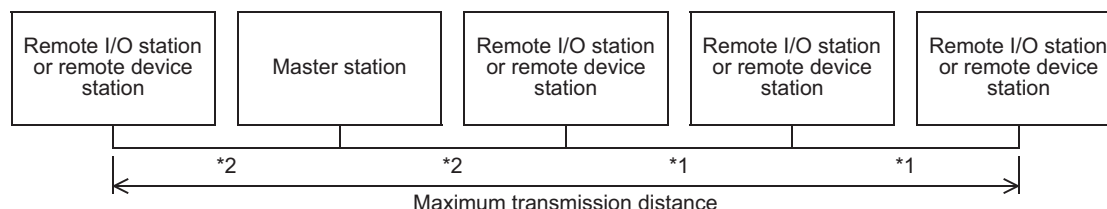

- *1. Cable length between remote I/O or remote device stations
- *2. Cable length between the master station and an adjacent station
- CC-Link dedicated cable (requiring terminal resistor of 110Ω)

Transmission speed	Cable length between stations		Maximum transmission distance
	*1	*2	
156 kbps	30 cm or more	1 m or more	1200 m
625 kbps			600 m
2.5 Mbps			200 m
5 Mbps	30 cm to 59 cm ^{*3}		110 m
	60 cm or more		150 m
10 Mbps	30 cm to 59 cm ^{*3}		50 m
	60 cm to 99 cm ^{*3}	80 m	
	1 m or more	100 m	

- *3. The cable length between remote I/O stations or remote device stations is within this range and if even one location is wired, the maximum overall cable distance will be as indicated above.

- 1 Introduction
- 2 Specification
- 3 System Configuration
- 4 Installation
- 5 Wiring
- 6 Introduction of Functions
- 7 Data Link Processing Time
- 8 Parameter Setting
- 9 Data Link Procedure
- 10 Buffer Memory

- CC-Link dedicated high-performance cable (requiring terminal resistor of 130Ω)

Transmission speed	Cable length between stations		Maximum transmission distance
	*1	*2	
156 kbps	30 cm or more	1 m or more	1200 m
625 kbps			900 m
2.5 Mbps			400 m
5M bps			160 m
10M bps			100 m

2. In the system consisting of remote I/O stations, remote device stations and intelligent device stations

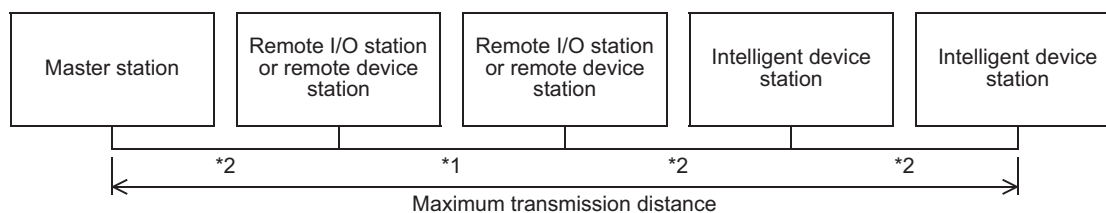

- *1. Cable length between remote I/O or remote device stations
- *2. Cable length between the master station or intelligent device stations and an adjacent station

- CC-Link dedicated cable (requiring terminal resistor of 110Ω)

Transmission speed	Cable length between stations		Maximum transmission distance
	*1	*2	
156 kbps	30 cm or more	2 m or more	1200 m
625 kbps			600 m
2.5 Mbps			200 m
5 Mbps	30 cm to 59 cm ^{*3}		110 m
	60 cm or more		150 m
10 Mbps	30 cm to 59 cm ^{*3}		50 m
	60 cm to 99 cm ^{*3}	80 m	
	1 m or more	100 m	

- CC-Link dedicated high-performance cable (requiring terminal resistor of 130Ω)

Transmission speed	Cable length between stations		Maximum transmission distance
	*1	*2	
156 kbps	30 cm or more	2 m or more	1200 m
625 kbps			600 m
2.5 Mbps			200 m
5 Mbps	30 cm to 59 cm ^{*3}		110 m
	60 cm or more		150 m
10 Mbps	70 cm to 99 cm ^{*3}		50 m
	1 m or more	100 m	

- *3. The cable length between remote I/O stations or remote device stations is within this range and if even one location is wired, the maximum overall cable distance will be as indicated above.

2.5.2 Maximum transmission distance (for Ver. 1.10)

The relation of the transmission speed and maximum overall cable distance when configuring the entire system with Ver. 1.10 units and cable is shown below.

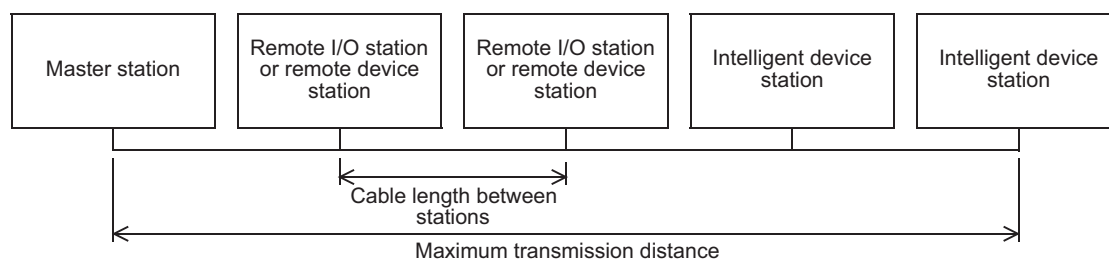

- Ver.1.10 compatible CC-Link dedicated cable (requiring terminal resistor of 110Ω)

Transmission speed	Cable length between stations	Maximum transmission distance
156 kbps	20 cm or more	1200 m
625 kbps		900 m
2.5 Mbps		400 m
5 Mbps		160 m
10 Mbps		100 m

2.6 CC-Link Dedicated Cable

Use dedicated CC-Link cables in the CC-Link system.

If any other cable is used, the performance of the CC-Link system cannot be guaranteed.

For the specifications of CC-Link dedicated cables, please refer to the CC-Link Partner Association or the following website.

- CC-Link Partner Association:
<http://www.cc-link.org/>

Remarks

For details, refer to the CC-Link wiring manual issued by CC-Link Partner Association.

1	Introduction
2	Specification
3	System Configuration
4	Installation
5	Wiring
6	Introduction of Functions
7	Data Link Processing Time
8	Parameter Setting
9	Data Link Procedure
10	Buffer Memory

3. System Configuration

This chapter describes the system configuration for the CC-link system in which an FX Series PLC functions as the master station.

3.1 General Configuration

Up to 16 remote stations and intelligent device stations can be connected to the FX3U-16CCL-M. However, the following conditions must be satisfied for connections:

1. Number of connectable units to the main unit

Only one FX3U-16CCL-M unit can be connected to a main unit. An FX3U-16CCL-M cannot be attached to a main unit that has an FX2N-16CCL-M and/or FX2N-32ASI-M connected already.

2. Maximum number of I/O points per system

When using an FX3U/FX3UC PLC

1) + 2) total number of points ≤ 384

1) (Actual number of PLC I/O points) + (Number of points occupied by special function blocks) + (Number of points occupied by the FX3U-16CCL-M: 8 points) ≤ 256 points

2) $32 \times \text{Number of remote I/O stations} \leq 256$

When using an FX3G/FX3GC PLC

$32 \times \text{Number of remote I/O stations} \leq 128$

3. Maximum number of connectable stations

1) Remote I/O stations: 8 maximum
(Each station occupies 32 I/O points of the PLC.)

2) Remote device stations + Intelligent device stations ≤ 8 maximum
(The total number of RX/RV points is 256 or less.)

3.1.1 CC-Link network configuration

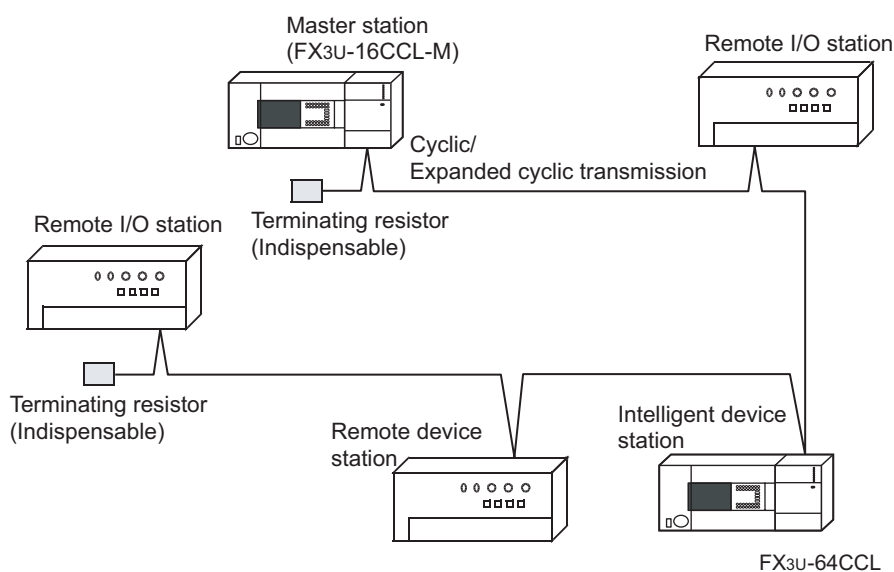

3.1.2 Example of CC-Link system configuration

Example of system configuration

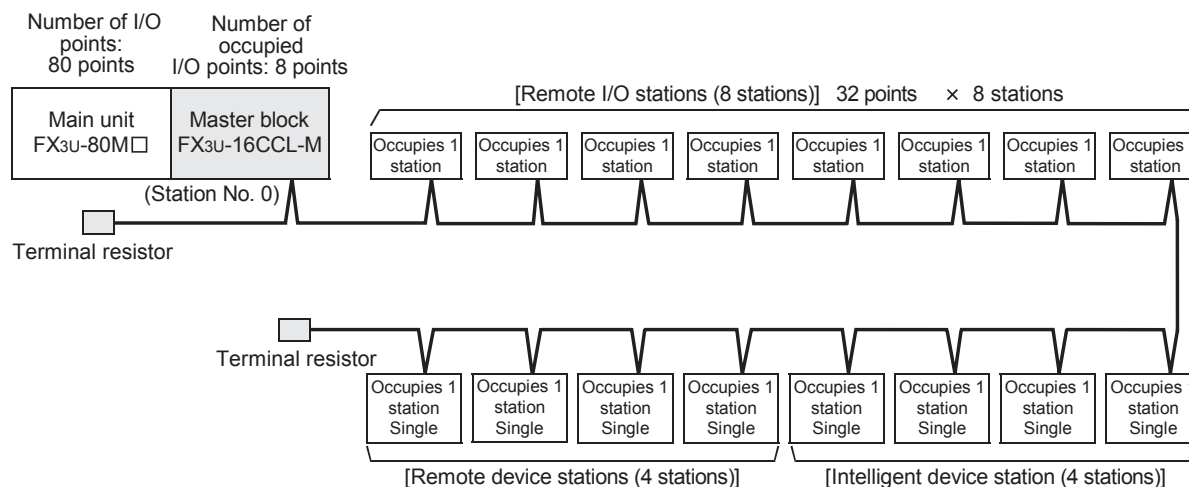

Confirmation of system configuration validity

- Number of connectable units to the main unit
There is no problem since only 1 unit can be connected to the main unit.
- Maximum number of I/O points per system

Actual number of PLC I/O points	80 points
Number of points occupied by special function blocks	0 point
Number of points occupied by the FX3U-16CCL-M	8 points
32 points × Number of remote I/O stations	256 points
Total: 344 points	

384 points (FX3U maximum number of input/output points) - 344 points = 40 points (remaining number of I/O points)

In the configuration above, up to 40 I/O points or special function blocks corresponding to up to 40 points can be added.

- Maximum number of connectable stations

Remote I/O station	8 stations
The total number of stations: Remote device stations + Intelligent device stations	8 stations
The total number of RX/RV points: Remote device stations + Intelligent device stations	256 points

There is no problem since no restrictions are violated.

3.2 Applicable PLC

Applicable PLC		Description
Model name	Version	
FX3G Series PLC FX3GC Series PLC* ¹	Ver. 1.00 or later	Support the FX3U-16CCL-M.
	Ver. 2.00 or later	Support the following functions.* ² <ul style="list-style-type: none"> • Network parameter setting with GX Works2. • Accessing the other station from CC-Link. • Remote device station initialization procedure registration function. • CC-Link diagnostics.
FX3U Series PLC FX3UC Series PLC* ¹	Ver. 2.20 or later	Support the FX3U-16CCL-M.
	Ver. 3.10 or later	Support the following functions.* ³ <ul style="list-style-type: none"> • Network parameter setting with GX Works2. • Accessing the other station from CC-Link. • Remote device station initialization procedure registration function. • CC-Link diagnostics.

Only one FX3U-16CCL-M unit can be connected to a main unit.

The version number can be checked by reading the last three digits of device D8001/D8101.

- *1. An FX2NC-CNV-IF or FX3UC-1PS-5V is necessary to connect the FX3U-16CCL-M with the FX3GC/FX3UC PLC.
- *2. GX Works2 Ver. 1.87R or later is required.
- *3. GX Works2 Ver. 1.73B or later is required.

3.3 Connection with PLC

The FX3U-16CCL-M connects with a PLC via an extension cable.

The FX3U-16CCL-M is handled as a special extension block of the PLC. The unit number of the FX3U-16CCL-M is automatically assigned No. 0 to No. 7 (Unit No. 1 to No. 7 is assigned when the main unit is an FX3UC-32MT-LT(-2).) starting from the special function unit/block closest to the PLC main unit.

(This unit number is used for the designation of a FROM/TO instruction.)

For details on the assignment of the I/O number and unit number of the PLC, refer to the following manual corresponding to the connected PLC.

- Refer to **FX3G Hardware Edition**.
- Refer to **FX3U Hardware Edition**.
- Refer to **FX3GC Hardware Edition**.
- Refer to **FX3UC Hardware Edition**.

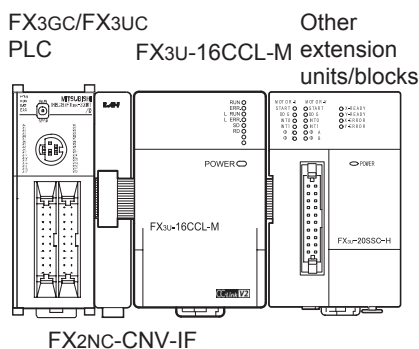
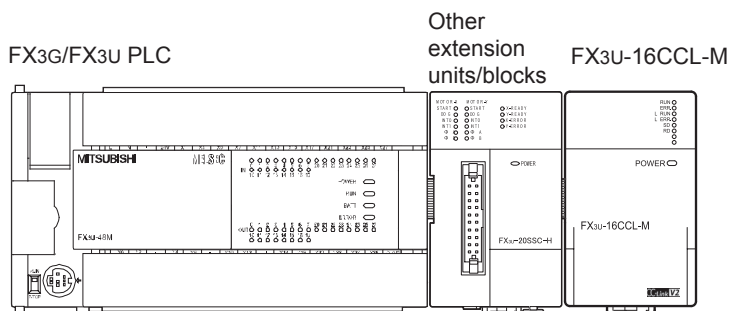

- Only one FX3U-16CCL-M unit can be connected to the FX3G/FX3U/FX3GC/FX3UC PLC.
- An FX2NC-CNV-IF or FX3UC-1PS-5V is necessary to connect the FX3U-16CCL-M with the FX3GC/FX3UC PLC.
- The optional FX0N-65EC (FX0N-30EC) and FX2N-CNV-BC are necessary to lengthen the extension cable.
- The number of I/O points occupied by the FX3U-16CCL-M is eight. Make sure that the total number of I/O points (occupied I/O points) of the main unit, extension unit(s), extension block(s) and the number of points occupied by special function blocks does not exceed the maximum number of I/O points of the PLC.

For information on the maximum number of I/O points of the PLC, refer to the respective product manual.

- Refer to **FX3G Hardware Edition**.
- Refer to **FX3U Hardware Edition**.
- Refer to **FX3GC Hardware Edition**.
- Refer to **FX3UC Hardware Edition**.

3.4 Number of Occupied Stations and Station numbers as well as Number of Units and Number of Stations

This section describes the relationship between the number of occupied stations and the station number as well as between the number of units and the number of stations.

1. Number of occupied stations

It is the number of stations on the network which a single remote device station or intelligent device station use. According to the number of data, 1 to 4 stations can be set. However, a remote I/O station can only occupy 1 station.

2. Station Number

The station number of the master station is 0.

The station number of the remote stations and intelligent device station are assigned between 1 to 16. If there is a station unit occupying 2 or more stations, the number of occupied stations should be taken into account when the station numbers are assigned.

3. Number of units and number of stations

The number of units indicates the number of physical modules.

The number of stations indicates the number of stations occupied by remote stations and intelligent device stations.

3.5 Precautions When Configuring the System

Design the system with the following considerations to prevent erroneous inputs from remote I/O units.

1. Timing of power ON and power OFF

Turn on the power of remote I/O units first, then start the data link.

Stop the data link first, then turn off the power of remote I/O units.

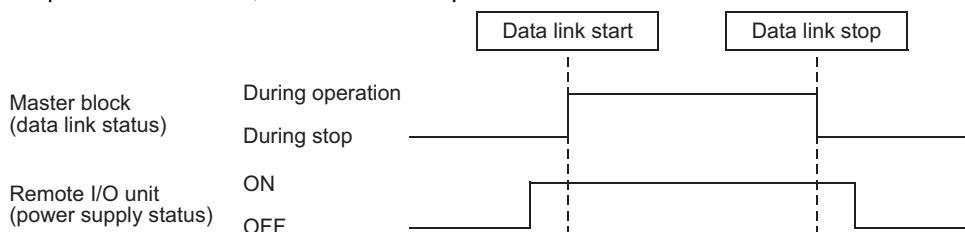

2. Momentary power failure in remote I/O units

When momentary power failure occurs in the power (24 V DC) supplied to remote I/O units, erroneous input may occur.

1) Cause for erroneous input due to momentary power failure

The remote I/O unit hardware converts the module power (24 V DC) into 5 V DC inside the module, then uses the 5 V DC.

When momentary power failure occurs in a remote I/O unit, the following condition occurs:

(Time until 5 V DC inside remote I/O unit turns off) > (Input unit ON → OFF response time)

Therefore, erroneous input is caused when refresh is executed within the period of time indicated by ① in the diagram below.

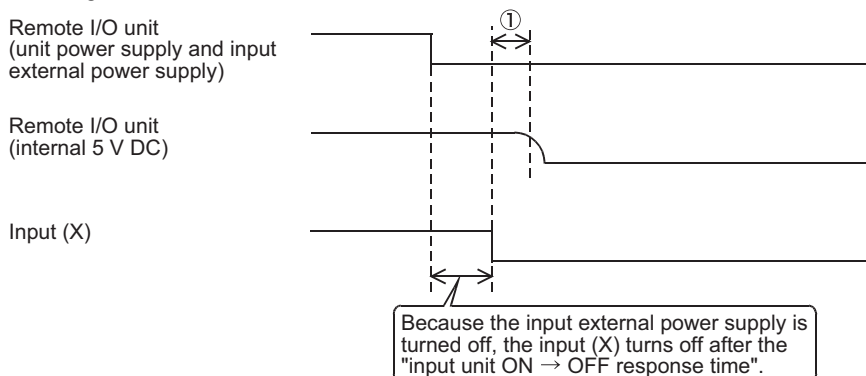

- 2) Countermeasures against erroneous input
For the main unit, the stabilized power supply and the input external supply power of AC input, wire the power cables from the same power source.
- When external power supply to input area is DC type

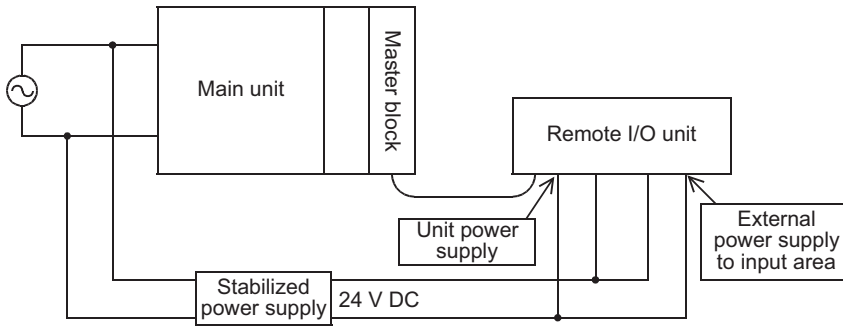

- When external power supply to input area is AC type

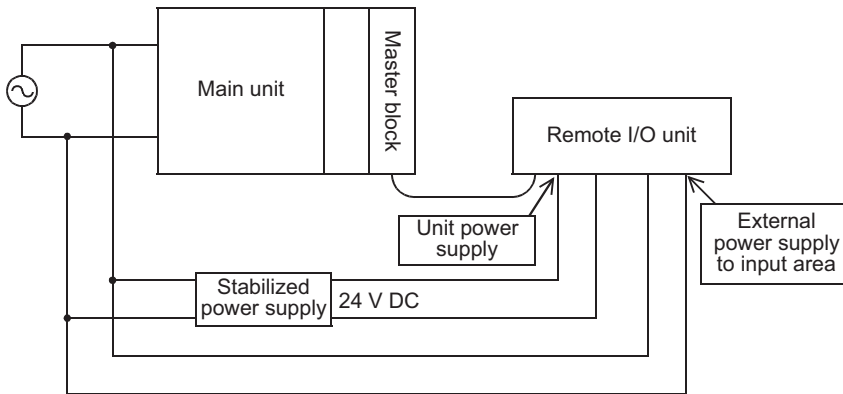

Caution

When supplying power from one power source to multiple remote I/O units, select cables and perform wiring with considerations to the voltage drop caused by the cables. Connections can be established if the receiving port voltage of the remote I/O unit is within the specification range of the remote I/O unit.

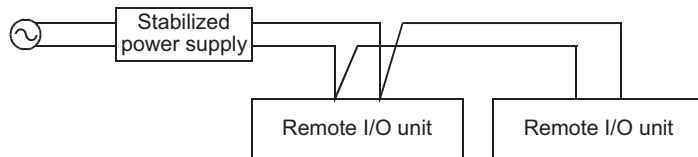

1	Introduction
2	Specification
3	System Configuration
4	Installation
5	Wiring
6	Introduction of Functions
7	Data Link Processing Time
8	Parameter Setting
9	Data Link Procedure
10	Buffer Memory

3.6 CC-Link Version

There are two different CC-Link versions: Ver. 1 and Ver. 2.

1. Definitions of Ver. 1.00 and Ver. 1.10

Ver. 1.10 is a version in which the station-to-station cable length was improved to 20 cm or more.

In contrast, the older version is defined as Ver. 1.00.

The station-to-station cable length must be 20 cm or more when the following conditions are met:

- All the modules that compose the CC-Link system are Ver. 1.10 units.
- All the data link cables are CC-Link Ver. 1.10-compatible cables.
→ **For the maximum overall cable length for Ver. 1.10, refer to Subsection 2.5.2.**

2. Definition of Ver. 2

Units supporting the extended cyclic transmission are defined as the Ver. 2 compatible units.

Note that the specifications of the cable remain the same as Ver. 1.10.

Caution

The specifications for Version 1.00 must be applied to the maximum cable overall length and station-to-station cable length if a system contains all of Ver. 1.00, Ver. 1.10, and Ver. 2 compatible units.

- **For the maximum overall cable length and station-to-station cable length of Ver. 1.00, refer to Subsection 2.5.1.**

4. Installation

INSTALLATION PRECAUTIONS



DANGER

- Make sure to cut off all phases of the power supply externally before attempting installation work. Failure to do so may cause electric shock or damage to the product.

INSTALLATION PRECAUTIONS



CAUTION

- Use the product within the generic environment specifications described in PLC main unit manual (Hardware Edition). Never use the product in areas with excessive dust, oily smoke, conductive dusts, corrosive gas (salt air, Cl₂, H₂S, SO₂, or NO₂), flammable gas, vibration or impacts, or expose it to high temperature, condensation, or rain and wind. If the product is used in such conditions, electric shock, fire, malfunctions, deterioration or damage may occur.
- Do not touch the conductive parts of the product directly. Doing so may cause device failures or malfunctions.
- Install the product securely using a DIN rail or mounting screws.
- Install the product on a flat surface. If the mounting surface is rough, undue force will be applied to the PC board, thereby causing nonconformities.
- When drilling screw holes or wiring, make sure that cutting and wiring debris do not enter the ventilation slits. Failure to do so may cause fire, equipment failures or malfunctions.
- Be sure to remove the dust proof sheet from the PLC's ventilation port when installation work is completed. Failure to do so may cause fire, equipment failures or malfunctions.
- Make sure to attach the top cover, offered as an accessory, before turning on the power or initiating operation after installation or wiring work. Failure to do so may cause electric shock.
- Connect extension cables securely to their designated connectors. Loose connections may cause malfunctions.

Only one FX3U-16CCL-M unit can be connected to the right side of the main unit, extension unit or extension block.

To connect to an FX3GC/FX3UC PLC or FX2NC PLC extension block, the FX2NC-CNV-IF or FX3UC-1PS-5V is necessary.

For details, refer to the respective PLC manual.

→ Refer to FX3G Hardware Edition.

→ Refer to FX3U Hardware Edition.

→ Refer to FX3GC Hardware Edition.

→ Refer to FX3UC Hardware Edition.

The FX3U-16CCL-M may be installed in a control cabinet with a 35 mm wide DIN46277 DIN rail mounting or M4 screw direct mounting.

1

Introduction

2

Specification

3

System Configuration

4

Installation

5

Wiring

6

Introduction of Functions

7

Data Link Processing Time

8

Parameter Setting

9

Data Link Procedure

10

Buffer Memory

4.1 DIN rail Mounting

The product may be mounted on a 35 mm wide DIN46277 (DIN rail).

- 1 **Fit the upper edge (A in the figure to the right) of the DIN rail mounting groove onto the DIN rail.**
- 2 **Push the product onto the DIN rail.**
 - An interval space of 1 to 2 mm (0.04" to 0.08") between each unit is necessary.
- 3 **Connect the extension cable.**

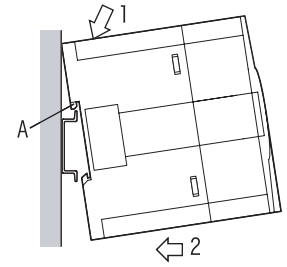

Connect the extension cable (B in the figure to the right) to the main unit, I/O extension unit/block or special function unit/block on the left side of the product.

For information on the extension cable connection procedure, refer to the respective product PLC manual.

- Refer to FX3G Hardware Edition.
- Refer to FX3U Hardware Edition.
- Refer to FX3GC Hardware Edition.
- Refer to FX3UC Hardware Edition.

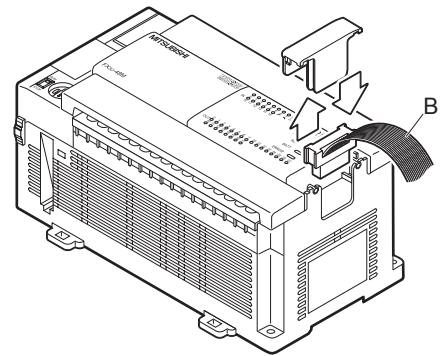

- Example of installation on DIN rail
 - In the case of the FX3G/FX3U PLC

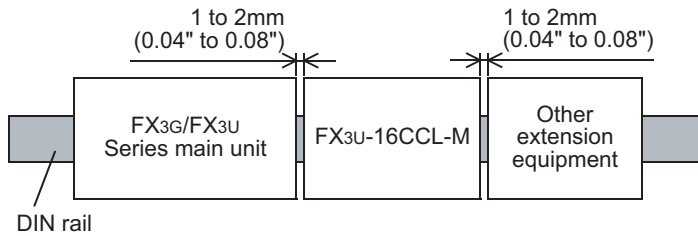

- In the case of the FX3GC/FX3UC PLC

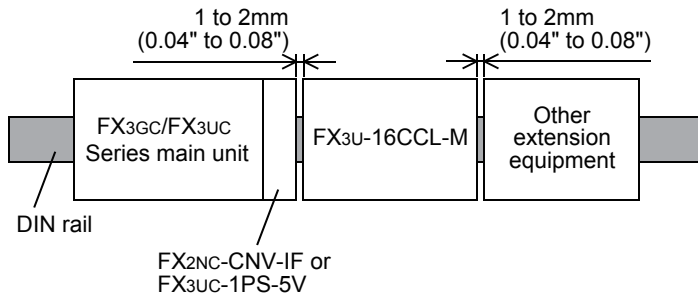

4.2 Direct Mounting

The product can be installed directly with screws.
An interval space of 1 to 2 mm (0.04" to 0.08") between each unit is necessary.
For installation details, refer to the following respective PLC manual.

- For mounting hole pitches, refer to Section 1.2.
 - Refer to FX3G Hardware Edition.
 - Refer to FX3U Hardware Edition.
 - Refer to FX3GC Hardware Edition.
 - Refer to FX3UC Hardware Edition.

1 Create mounting holes in the mounting surface according to the external dimensions diagram.

2 Fit the FX3U-16CCL-M (A in the figure to the right) to the mounting holes and tighten with M4 screws (B in the figure to the right).

For the screw position and quantity, refer to the dimensioned drawing specified below.

- For dimensions, refer to Section 1.2.

3 Connect the extension cable.

Connect the extension cable to the main unit, I/O extension unit/block or special function unit/block on the left side of the product.

(Refer to Step 3 in Section 4.1.)

For information on the extension cable connection procedure, refer to the respective PLC manual.

- Refer to FX3G Hardware Edition.
- Refer to FX3U Hardware Edition.
- Refer to FX3GC Hardware Edition.
- Refer to FX3UC Hardware Edition.

- Example of direct installation

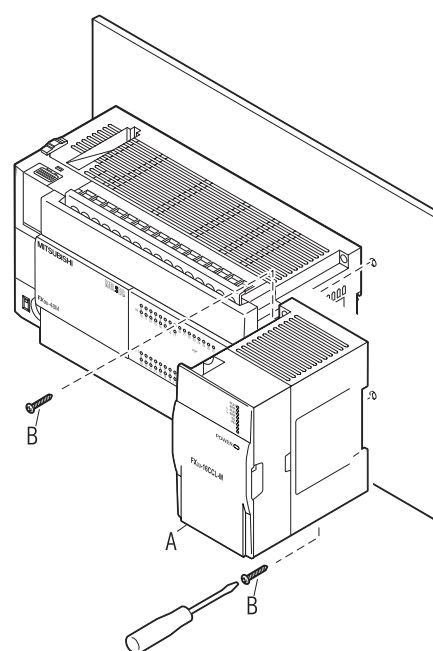
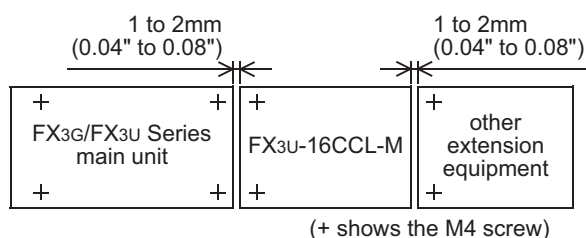

1	Introduction
2	Specification
3	System Configuration
4	Installation
5	Wiring
6	Introduction of Functions
7	Data Link Processing Time
8	Parameter Setting
9	Data Link Procedure
10	Buffer Memory

5. Wiring

WIRING PRECAUTIONS



DANGER

- Make sure to cut off all phases of the power supply externally before attempting wiring work. Failure to do so may cause electric shock or damage to the product.

WIRING PRECAUTIONS

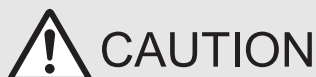

CAUTION

- Connect the DC power supply wiring to the dedicated terminal described in this manual. If an AC power supply is connected to a DC input/output terminal or DC power supply terminal, the PLC will burn out.
- Perform class D grounding (grounding resistance: 100Ω or less) to the grounding terminal on the FX3U-16CCL-M with a wire as thick as possible. Do not use common grounding with heavy electrical systems.
- Make sure to attach the top cover, offered as an accessory, before turning on the power or initiating operation after installation or wiring work. Failure to do so may cause electric shock.
- When drilling screw holes or wiring, make sure that cutting and wiring debris do not enter the ventilation slits. Failure to do so may cause fire, equipment failures or malfunctions.
- For the CC-Link system, use CC-Link dedicated cables. The performance of the CC-Link system cannot be guaranteed with any cable other than CC-Link dedicated cables. For the maximum total extension length and the cable length between stations, observe the specification described in the Section 2.5. With wiring outside the specification range, normal data transfer cannot be guaranteed.
- Do not bundle the CC-Link dedicated cable together with or lay it close to the main circuit, high-voltage line, or load line. As a guideline, lay the control line at least 100mm (3.94") or more away from the main circuit, high-voltage line, or load line. Otherwise, noise disturbance and/or surge induction are likely to take place.
- Make sure to fix communication cables and power cables connected to the module by placing them in the duct or clamping them. Cables not placed in duct or not clamped may hang or shift, allowing them to be accidentally pulled, which may result in malfunction or damage to the module and the cables.
- When disconnecting a communication/power cable connected to the module, do not hold the cable area. For a cable connected to a terminal block, loosen screws of the terminal block, then disconnect the cable. If a cable is pulled while it is connected to a module, the module may malfunction or the module and the cable may be damaged.
- Make sure to properly wire the extension equipment in accordance with the following precautions. Failure to do so may cause electric shock, equipment failures, a short-circuit, wire breakage, malfunctions, or damage to the product.
 - The disposal size of the cable end should follow the dimensions described in the manual.
 - Tightening torque should follow the specifications in the manual.

5.1 Power Supply Wiring

5.1.1 Power supply wiring

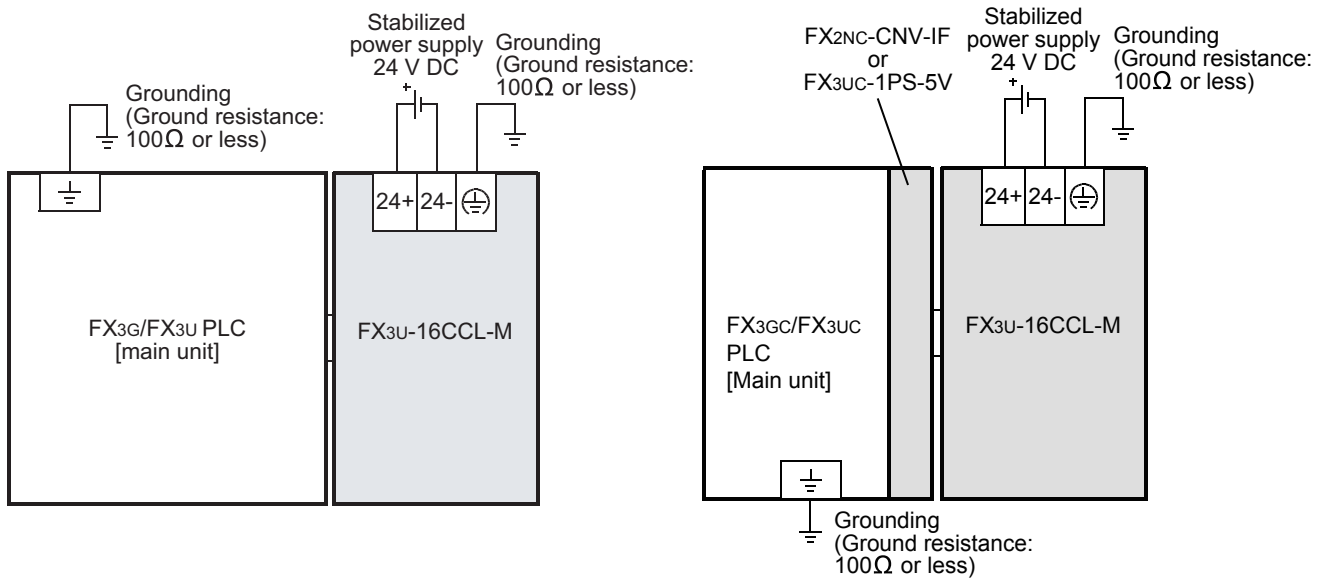

Power-on/off timing

The FX3U-16CCL-M power supply should be turned ON simultaneously with or before the power supply of the PLC main unit. Before turning the power OFF, ensure the safety of the system and then simultaneously turn the main unit, FX3U-16CCL-M, and other extension equipment (the special extension equipment is included) OFF.

For details, refer to the respective PLC manual.

- Refer to FX3G Hardware Edition.
- Refer to FX3U Hardware Edition.
- Refer to FX3GC Hardware Edition.
- Refer to FX3UC Hardware Edition.

5.1.2 Grounding

Ground the cables as follows

- The grounding resistance should be 100 Ω or less.
- Independent grounding should be established whenever possible. Independent grounding should be performed for best results. When independent grounding is not configured, perform "shared grounding" as shown in the following figure.

For details, refer to the respective PLC manual.

- Refer to FX3G Hardware Edition.
- Refer to FX3U Hardware Edition.
- Refer to FX3GC Hardware Edition.
- Refer to FX3UC Hardware Edition.

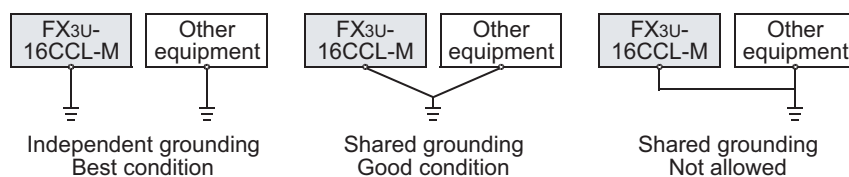

- The grounding point should be close to the FX3U-16CCL-M, and all grounding wires should be as short as possible.

5.2 CC-Link Wiring

5.2.1 Unit wiring with CC-Link dedicated cables

This subsection describes the connection method of CC-Link dedicated cables.

→ For details on CC-Link dedicated cables, refer to Section 2.6.

- CC-Link dedicated cables, Ver. 1.10 compatible CC-Link dedicated cables and CC-Link dedicated high-performance cables cannot be used together.
If used together, normal data transmission cannot be guaranteed.
- The cables can be connected without regard to the station number.
- The shielded CC-Link dedicated cable should be connected to the [SLD] and "[⊕] or [FG]" terminals in each unit, and both ends should have Class D grounding.
The terminals [SLD] and "[⊕] or [FG]" are connected to each other inside the unit.
- Connect the supplied "terminal resistors" to FX3U-16CCL-M at both ends of the CC-Link system.
Connect the terminal resistors between [DA] and [DB].
- In the CC-Link system, the terminal resistor to be connected varies depending on the cable used.

Cable type	Terminal resistor
CC-Link dedicated cable	110 Ω 1/2W (brown, brown and brown)
CC-Link dedicated high-performance cable	
Ver. 1.10 compatible CC-Link dedicated cable	130 Ω 1/2W (brown, orange and brown)

- The FX3U-16CCL-M can be connected besides to the both ends.
- Star connection is not allowed.
- The figure below shows the connection method.

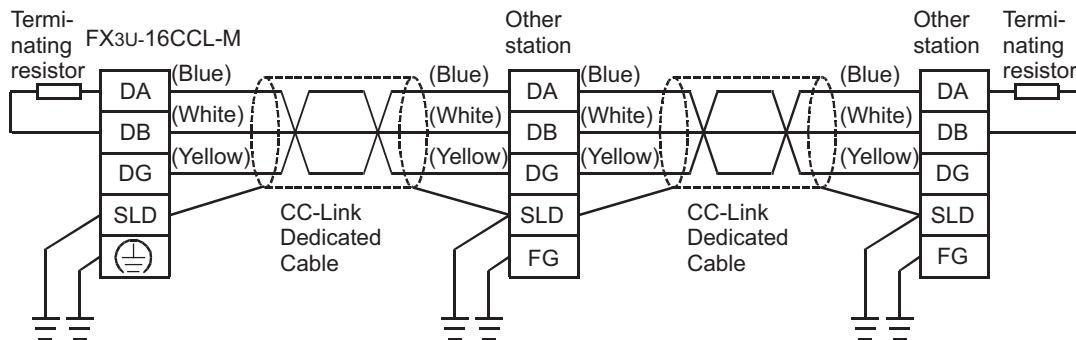

- In the CC-Link system, the maximum transmission and cable length distance between stations that can be set varies depending on the transmission speed.
→ For the maximum transmission and cable length distance between stations, refer to Section 2.5.

5.2.2 T-shaped Branch Connection Using CC-Link Dedicated Cables

This subsection describes the T-shaped branch connection using CC-Link dedicated cables.

1. System configuration with T-shaped branch connection

The figure below shows the system configuration with T-shaped branch connection.

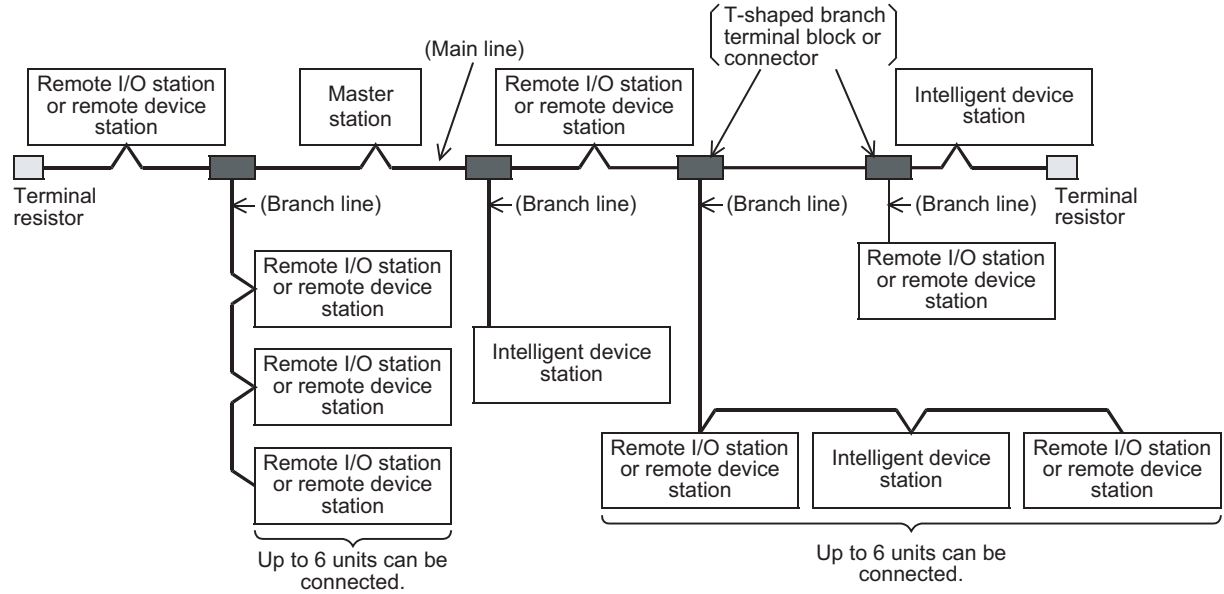

*The number of branch lines is determined by each branch line length and the total branch line length.

1	Introduction
2	Specification
3	System Configuration
4	Installation
5	Wiring
6	Introduction of Functions
7	Data Link Processing Time
8	Parameter Setting
9	Data Link Procedure
10	Buffer Memory

2. T-shaped branch communication specification list

The table below shows the communication specification in T-shaped branch connection. For communication specification not shown in the table below, refer to Section 2.3.

Item	Specification		Remarks		
Transmission speed	625 kbps	156 kbps	10, 5 and 2.5 Mbps are not available.		
Maximum main line length	100 m	500 m	The value indicates the cable length between terminal resistors. The cable length of T-shaped branch lines (branch length) is not included.		
Maximum branch line length	8 m		The value indicates the cable length per branch line.		
Total branch line length	50 m	200 m	The value indicates the total length of all branch lines.		
Maximum number of modules connected to branch line	6 units/branch line		The number of connected units conforms to the CC-Link specification.		
Connection cable	<ul style="list-style-type: none"> CC-Link dedicated cable Ver.1.10 compatible CC-Link dedicated cable 		<ul style="list-style-type: none"> CC-Link dedicated high-performance cables are not available. Mixing of different brands of CC-Link dedicated cables is not allowed. Mixing of different brands of Ver. 1.10 compatible CC-Link dedicated cables is allowed. 		
T-shaped branch terminal block/connector	<ul style="list-style-type: none"> Terminal block: Commercial one Connector: Connector for FA sensor NECA4202 or its equivalent is recommended. (NECA: THE JAPAN ELECTRIC CONTROL EQUIPMENT INDUSTRY ASSOCIATION Standards) 		When wiring cables to the main line, strip as little of the insulation as possible.		
Maximum main line length, T-shaped branch interval and cable length between units	CC-Link dedicated cable, Ver. 1.10 compatible CC-Link dedicated cable (uses 110 Ω terminal resistor)				
	Transmission speed	Maximum main line length	T-shaped branch interval	Length of cable between the remote I/O stations or remote device stations*1	Length of cable between the master station or intelligent device station and the adjacent station*2
	625 kbps	100 m	No limit	30 cm or more	1 m or more*3/2 m or more*4
156 kbps	500 m				

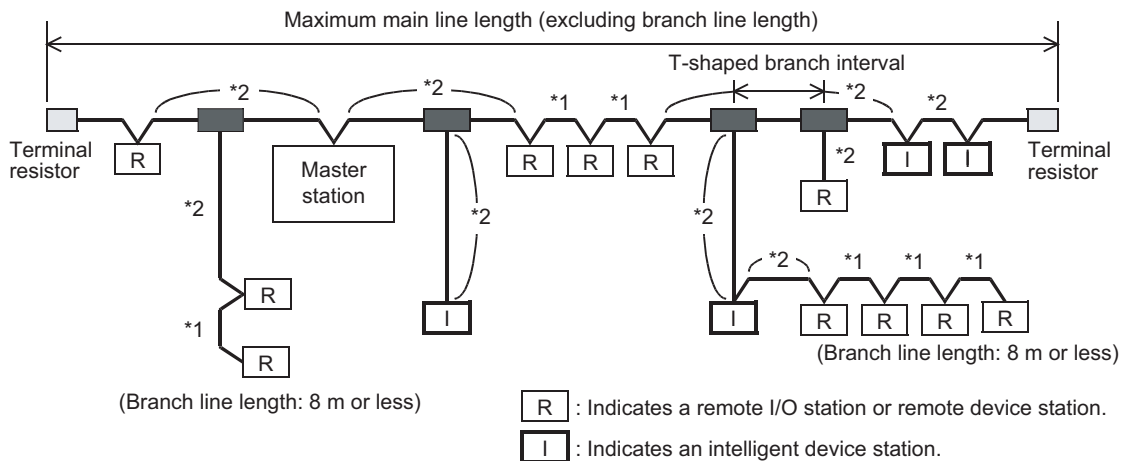

*3. The cable length of 1 m or more is for a system configured only with remote I/O stations and remote device stations.

*4. The cable length of 2 m or more is for a system configuration that contains intelligent device stations.

5.3 Screw Size and Tightening Torque

5.3.1 Terminal screw size and tightening torque

The power terminals and CC-Link connection terminals on the FX3U-16CCL-M use M3 screws.

Refer to the figures below for cable end treatment.

Set the tightening torque to 0.42 to 0.58 N·m.

Do not tighten terminal screws exceeding the specified torque. Failure to do so may cause equipment failures or malfunctions.

- When one wire is connected to one terminal

6.2mm(0.24")
or less

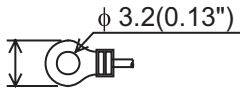

6.2mm(0.24")
or less

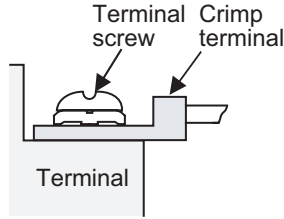
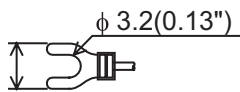

- When two wires are connected to one terminal

6.2mm(0.24")
or less

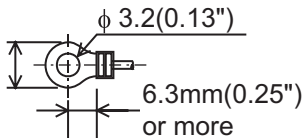

6.2mm(0.24")
or less

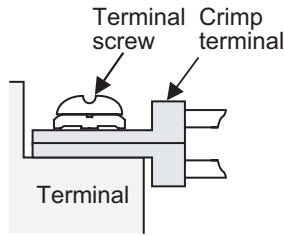
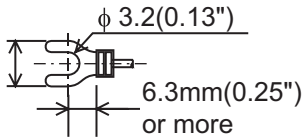

5.3.2 Terminal block mounting screw size and tightening torque

The CC-Link connection terminal block of the FX3U-16CCL-M can be removed.

(Black) mounting screws for the CC-Link connection terminal block are M3.5 size.

Set the tightening torque to 0.66 to 0.91 N·m.

Do not tighten the terminal block mounting screws exceeding the specified torque. Failure to do so may cause equipment failures or malfunctions.

1	Introduction
2	Specification
3	System Configuration
4	Installation
5	Wiring
6	Introduction of Functions
7	Data Link Processing Time
8	Parameter Setting
9	Data Link Procedure
10	Buffer Memory

6. Introduction of Functions

6.1 Functions List

1. Basic Functions

Function	Outline	Reference
Communication between master station and remote I/O stations	Transfers ON/OFF information with remote I/O stations.	Subsection 6.2.1
Communication between master station and remote device stations	Transfers ON/OFF information and the numeric data with remote device stations.	Subsection 6.2.2
Communication between master station and intelligent device stations	Transfers ON/OFF information and the numeric data with intelligent device stations.	Subsection 6.2.3
Communication in compound system	Transfers data with remote I/O stations, remote device stations and intelligent device stations.	Subsection 6.2.4
Network parameter setting with GX Works2	Sets the network parameters with GX Works2.	Subsection 6.2.5

2. RAS Functions

Function	Outline	Reference
Slave station cutoff function	Cuts off only slave stations in which data link is disabled by power OFF, etc., and continues the data link using only normal slave stations.	Subsection 6.3.1
Automatic return function	Allows a slave station which was disconnected from the data link by power OFF, etc. to automatically join the data link again when it recovers to normal status.	Subsection 6.3.2
Data link status setting against error in master station PLC CPU	Sets the data link status (continue or stop) for a case in which an operation stop error occurs in the master station PLC.	Subsection 6.3.3
Setting of input data status from data link faulty station	Sets the status (clear or keep) of the input (receive) data from a station in which data link is disabled due to power OFF, etc.	Subsection 6.3.4
Slave station refresh/compulsory clear setting in case of programmable controller CPU STOP	Sets whether output (send) data to the slave stations will be refreshed or compulsorily cleared when the programmable controller CPU enters STOP mode.	Subsection 6.3.5
Consistency control function	Consistency control functions assure data consistency for 1 word (16 bits) or more when read or written by the FROM/TO instructions, or data consistency for 2 words (32 bits) or more when read or written by the DFROM/DTO instructions.	Subsection 6.3.6

3. Handy functions

Function	Outline	Reference
Remote device station initialization procedure registration function	Performs initial setting of remote device station using GX Works2.	Subsection 6.4.1
Reserved station function	Sets slave stations to be connected in the future as reserved ones so that such stations are not handled as data link faulty stations.	Subsection 6.4.2
Error invalid station function	Sets slave stations as "error invalid" so that such stations are not handled as data link faulty stations.	Subsection 6.4.3
Temporary error invalid station specification function	Prevents units specified from being treated as data link faulty stations temporarily during online operation.	Subsection 6.4.4
Data link stop/restart	Stops or restarts the data link that is being executed.	Subsection 6.4.5
Station number overlap check function	Checks for the overlapping of number of occupied stations.	Subsection 6.4.6
Increasing the number of cyclic points	Allows the number of cyclic points per module to be increased from 128 points for RX/RX and 16 points for RWr/RWw in the ver. 1 mode to up to 224 points for RX/RX and 32 points for RWr/RWw in the ver. 2 mode.	Subsection 6.4.7
Accessing the other station from CC-Link	The operator can execute program writing, program reading, program verification and device batch monitoring to the main unit connected to a FX3U-64CCL from CC-Link using GX Works2.	Subsection 6.4.8

6.2 Basic Functions

6.2.1 Communication between master station and remote I/O stations

This subsection describes the overview of the communication between the master station and remote I/O stations.

In the communication with the remote I/O station, the on/off data of the switches and indicator lamps are communicated through remote input RX and remote output RY.

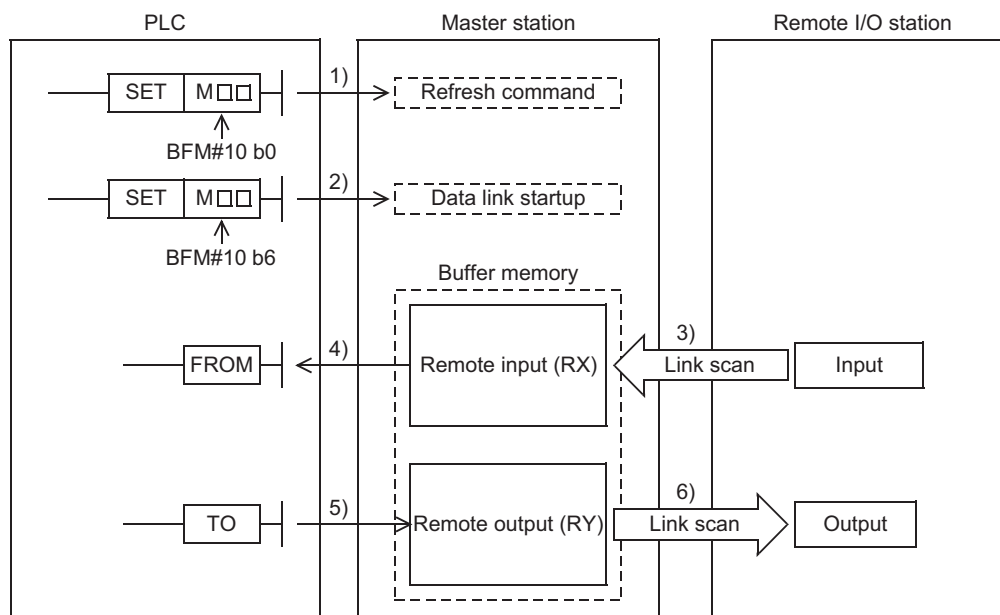

Data link startup

Two methods are available to start up data link, one method using buffer memories and another method using network parameters.

- Data link startup method using buffer memories

- 1) The PLC sets to ON the write refresh command (BFM#10 b0), and makes the data of the remote output (RY) effective.
When the write refresh command (BFM#10 b0) is OFF, all data of the remote output (RY) is treated as "0 (OFF)".
- 2) The PLC sets to ON the write data link startup by buffer memory parameters (BFM#10 b6) to start the data link.
When the data link starts normally, the read data link status in master station (BFM#10 b1) turns ON.

- Data link startup method using network parameters

Set network parameters to the main unit using GX Works2.

When network parameters are set, data link is automatically started up. (Data link startup processing is not required.)

Refer to Chapter 8 for network parameters.

Caution

Do not execute the data link startup method using buffer memories and data link startup method using network parameters at the same time.

Remote input

- 1) The input status of the remote I/O stations is automatically (for each link scan) stored in the buffer memory "remote input (RX)" in the master station.
- 2) The PLC receives the input status stored in the buffer memory "remote input (RX)" using the FROM instruction.

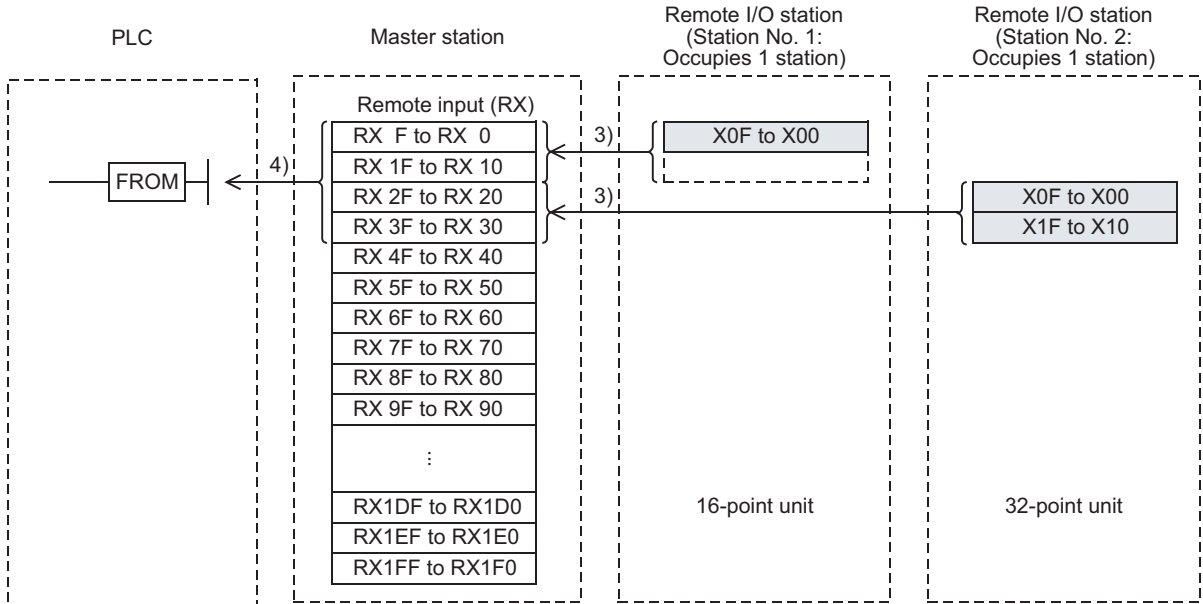

Remote output

- 3) The PLC writes the ON/OFF information output from the remote I/O station to the buffer memory "remote output (RY)" using the TO instruction.
- 4) The output status stored in the buffer memory "remote output (RY)" is automatically (for each link scan) output from the remote I/O stations.

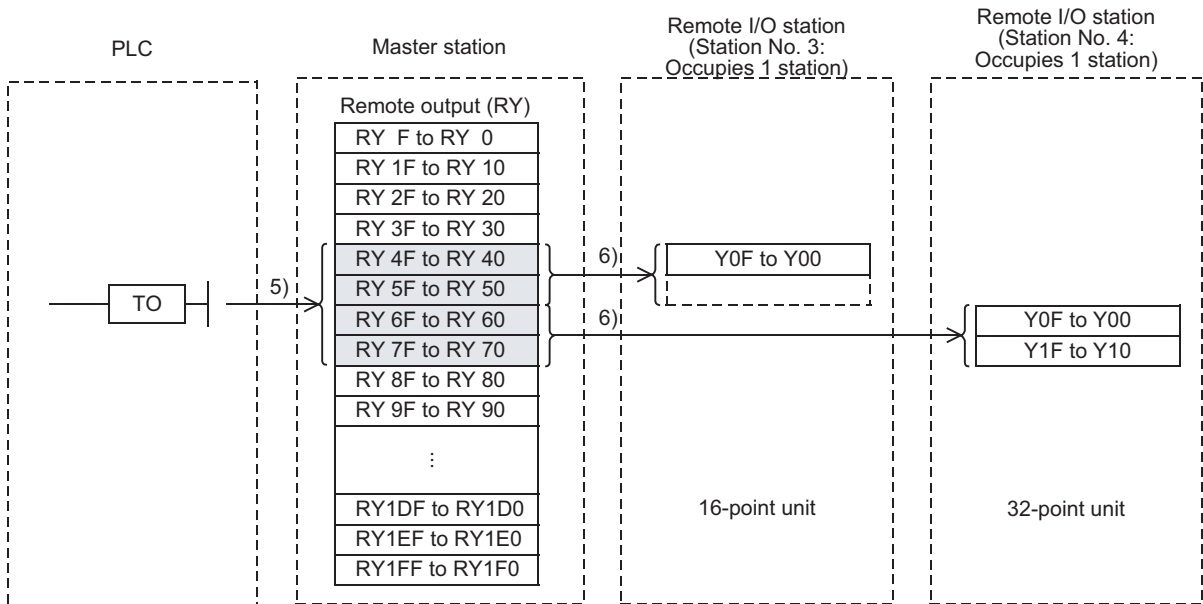

6.2.2 Communication between master station and remote device stations

This subsection describes the overview of the communication between the master station and remote device stations.

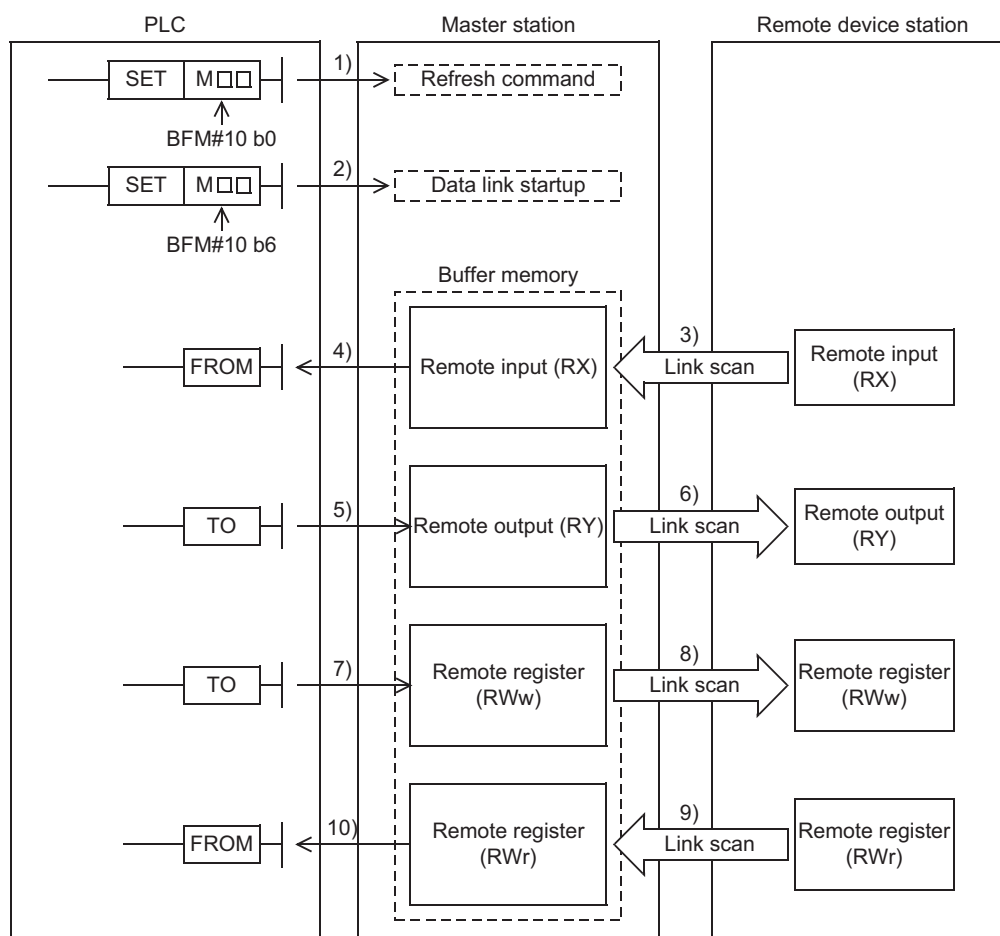

Data link startup

Two methods are available to start up data link, one method using buffer memories and another method using network parameters.

- Data link startup method using buffer memories

- 1) The PLC sets to ON the write refresh command (BFM#10 b0), and makes the data of the remote output (RY) effective.
When the write refresh command (BFM#10 b0) is OFF, all data of the remote output (RY) is treated as "0 (OFF)".
- 2) The PLC sets to ON the write data link startup by buffer memory parameters (BFM#10 b6) to start the data link.
When the data link starts normally, the read data link status in master station (BFM#10 b1) turns ON.

- Data link startup method using network parameters

Set network parameters to the main unit using GX Works2.

When network parameters are set, data link is automatically started up. (Data link startup processing is not required.)

Refer to Chapter 8 for network parameters.

Caution

Do not execute the data link startup method using buffer memories and data link startup method using network parameters at the same time.

Remote input

- 1) The remote input (RX) of the remote device stations is automatically (for each link scan) stored in the buffer memory "remote input (RX)" in the master station.
- 2) The PLC receives the input status stored in the buffer memory "remote input (RX)" using the FROM instruction.

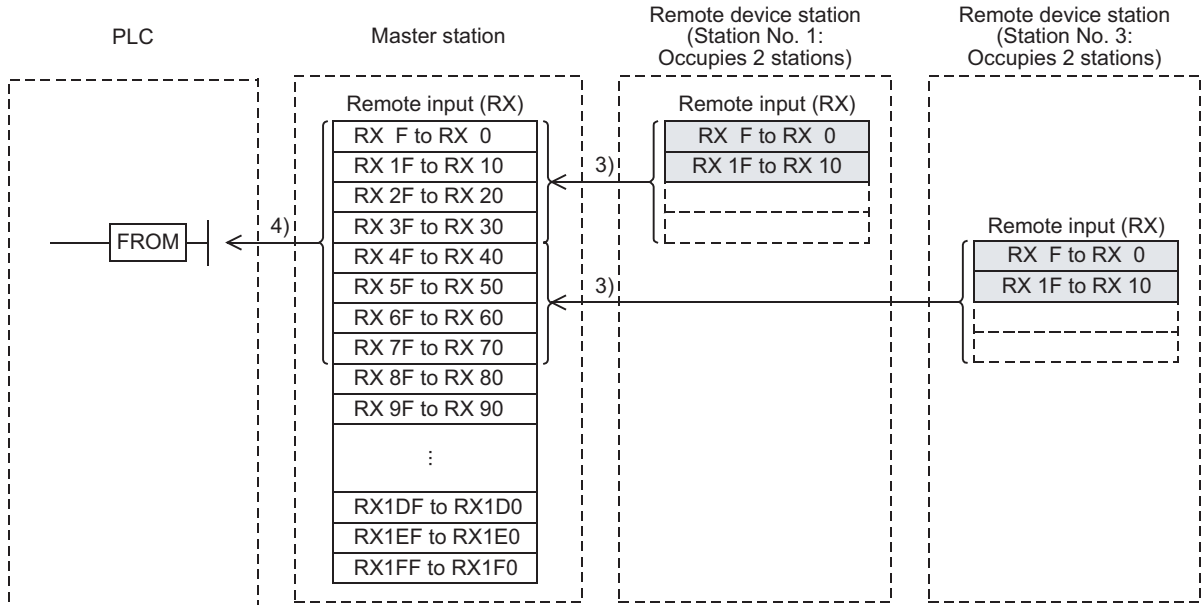

Remote output

- 3) The PLC writes the ON/OFF information of the remote output (RY) in the remote device stations to the buffer memory "remote output (RY)" using the TO instruction.
- 4) The remote output (RY) in the remote device stations is automatically (for each link scan) set to ON or OFF in accordance with the output status stored in the buffer memory "remote output (RY)".

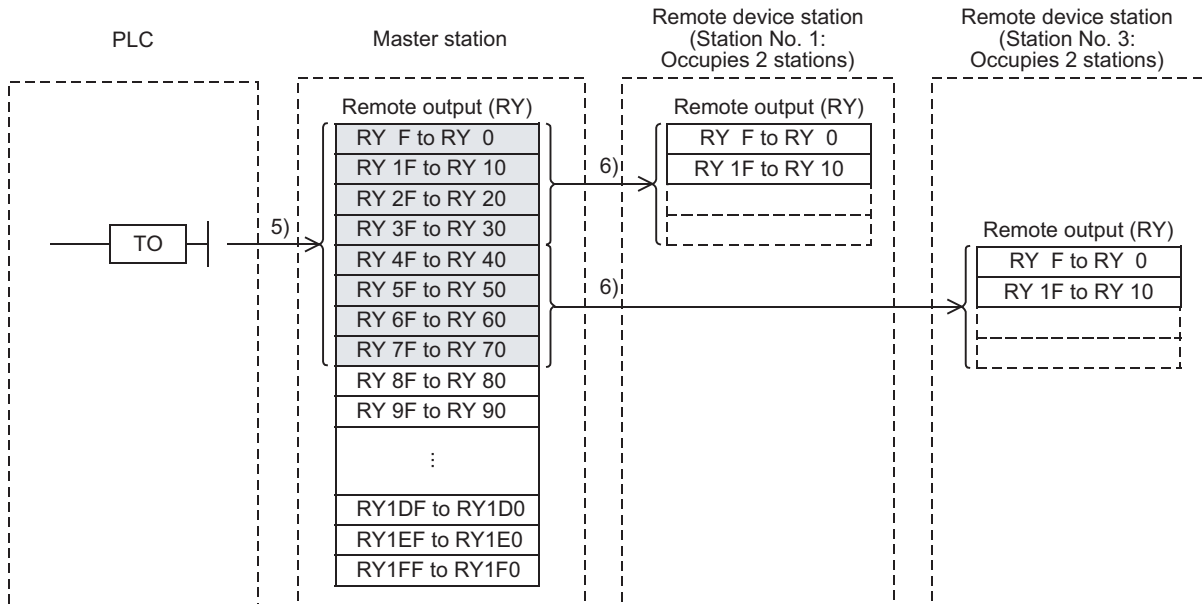

Write to remote register (RWw)

- 5) The PLC writes the transmission data to the buffer memory "remote register (RWw)" using the TO instruction.
- 6) The data stored in the buffer memory "remote register (RWw)" is automatically (for each link scan) transmitted to the remote register (RWw) in the remote device stations.

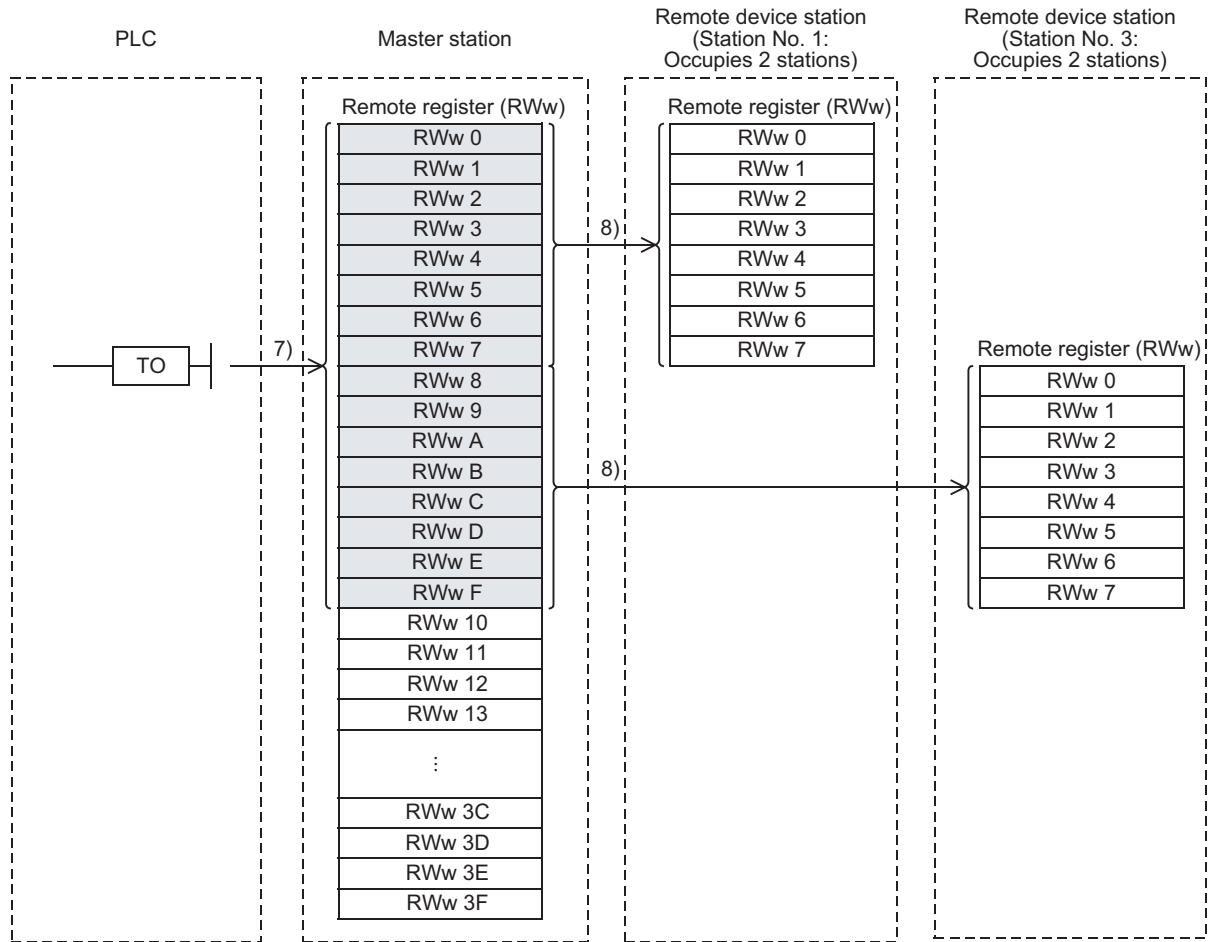

1	Introduction
2	Specification
3	System Configuration
4	Installation
5	Wiring
6	Introduction of Functions
7	Data Link Processing Time
8	Parameter Setting
9	Data Link Procedure
10	Buffer Memory

Read from remote register (RWr)

- 7) The data of the remote register (RWr) in the remote device stations is automatically (for each link scan) stored in the buffer memory "remote register (RWr)" in the master station.
- 8) The PLC receives the data of the remote register (RWr) in the remote device stations stored in the buffer memory "remote register (RWr)" using the FROM instruction.

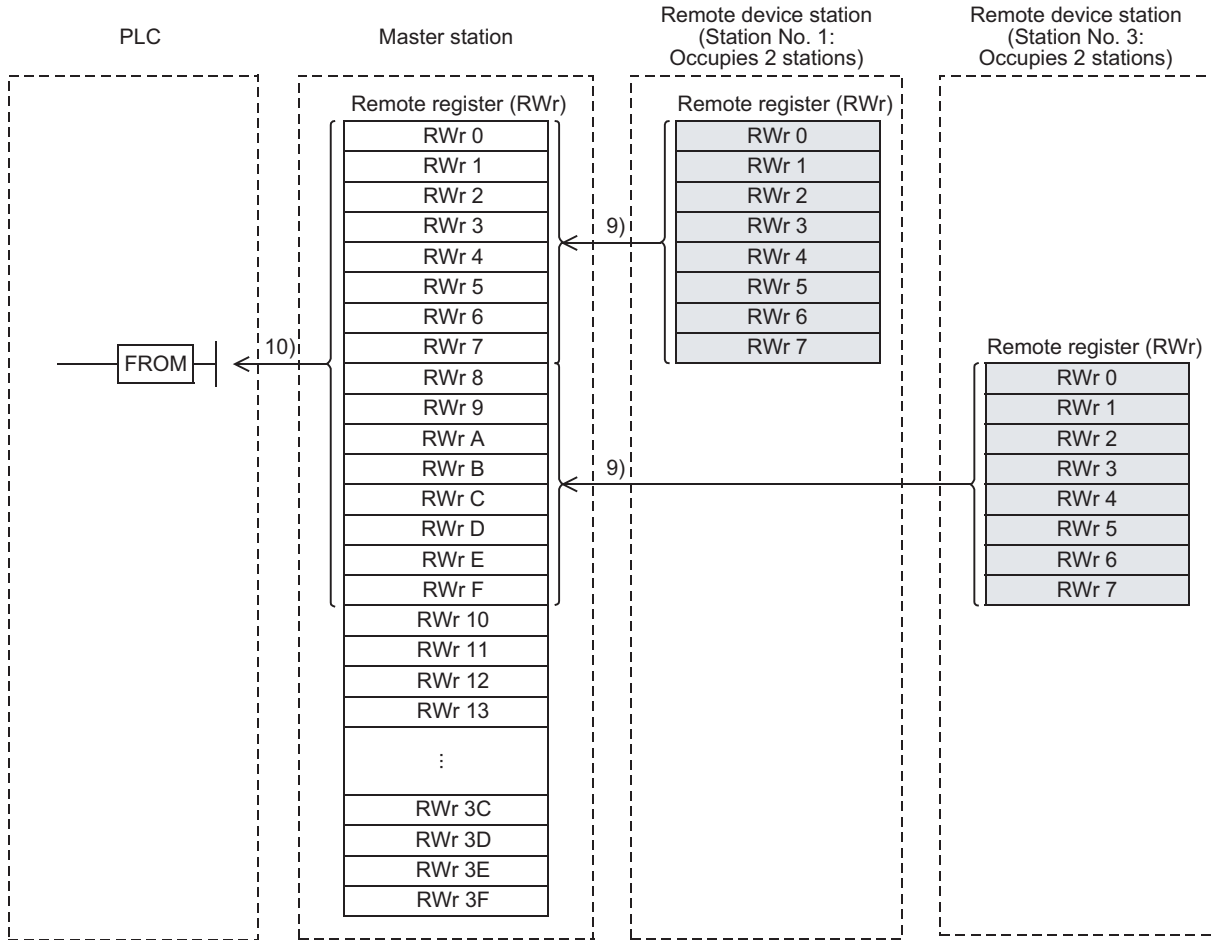

6.2.3 Communication between master station and intelligent device stations

This subsection describes the overview of the communication between the master station and intelligent device stations.

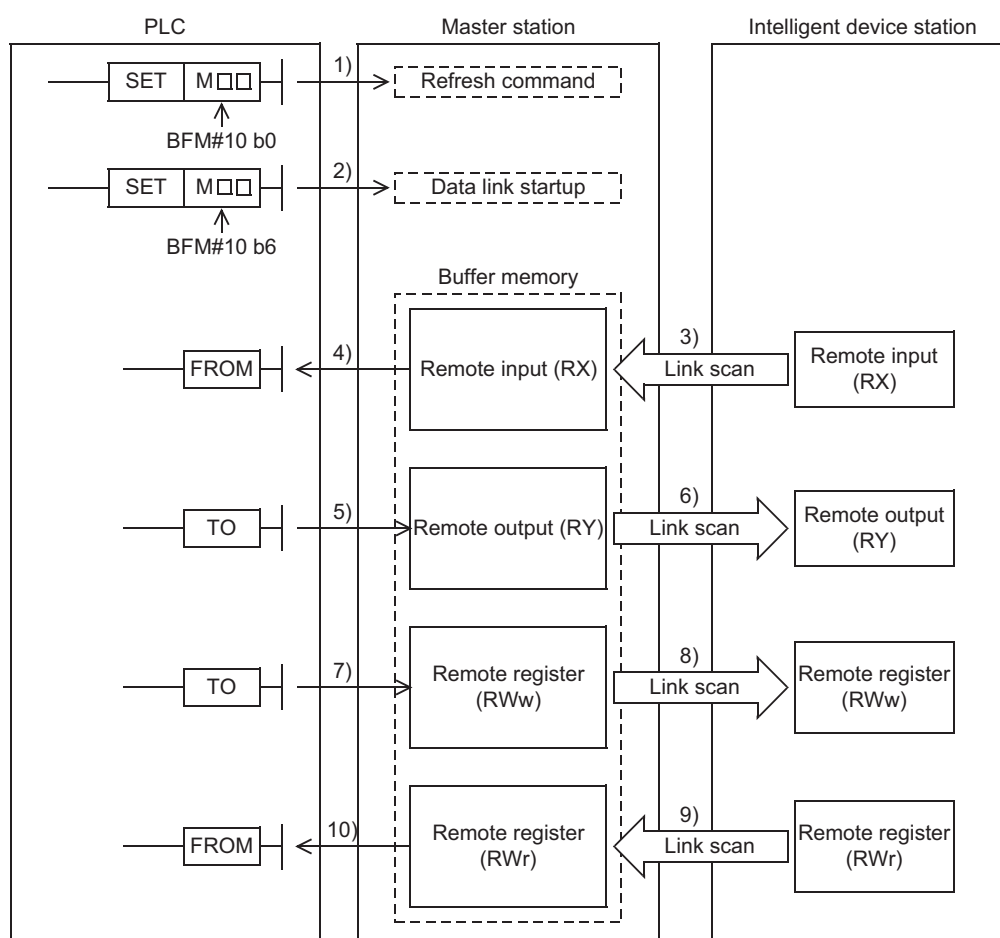

Data link startup

Two methods are available to start up data link, one method using buffer memories and another method using network parameters.

- Data link startup method using buffer memories

- 1) The PLC sets to ON the write refresh command (BFM#10 b0), and makes the data of the remote output (RY) effective.
When the write refresh command (BFM#10 b0) is OFF, all data of the remote output (RY) is treated as "0 (OFF)".
- 2) The PLC sets to ON the write data link startup by buffer memory parameters (BFM#10 b6) to start the data link.
When the data link starts normally, the read data link status in master station (BFM#10 b1) turns ON.

- Data link startup method using network parameters

Set network parameters to the main unit using GX Works2.

When network parameters are set, data link is automatically started up. (Data link startup processing is not required.)

Refer to Chapter 8 for network parameters.

Caution

Do not execute the data link startup method using buffer memories and data link startup method using network parameters at the same time.

1

Introduction

2

Specification

3

System Configuration

4

Installation

5

Wiring

6

Introduction of Functions

7

Data Link Processing Time

8

Parameter Setting

9

Data Link Procedure

10

Buffer Memory

Remote input

- 1) The remote input (RX) of the intelligent device stations is automatically (for each link scan) stored in the buffer memory "remote input (RX)" in the master station.
- 2) The PLC receives the input status stored in the buffer memory "remote input (RX)" using the FROM instruction.

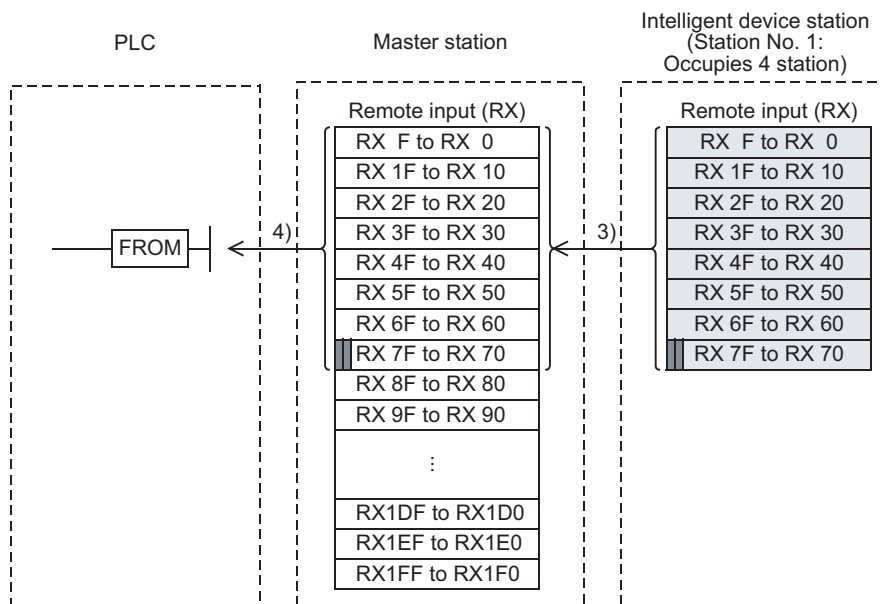

■ : The last 2 bits cannot be used in the communication between the master and intelligent device stations.
(In the example above, RX7E and RX7F cannot be used.)

Remote output

- 3) The PLC writes the ON/OFF information of the remote output (RY) in the intelligent device stations to the buffer memory "remote output (RY)" using the TO instruction.
- 4) The remote output (RY) in the intelligent device stations is automatically (for each link scan) set to ON or OFF in accordance with the output status stored in the buffer memory "remote output (RY)".

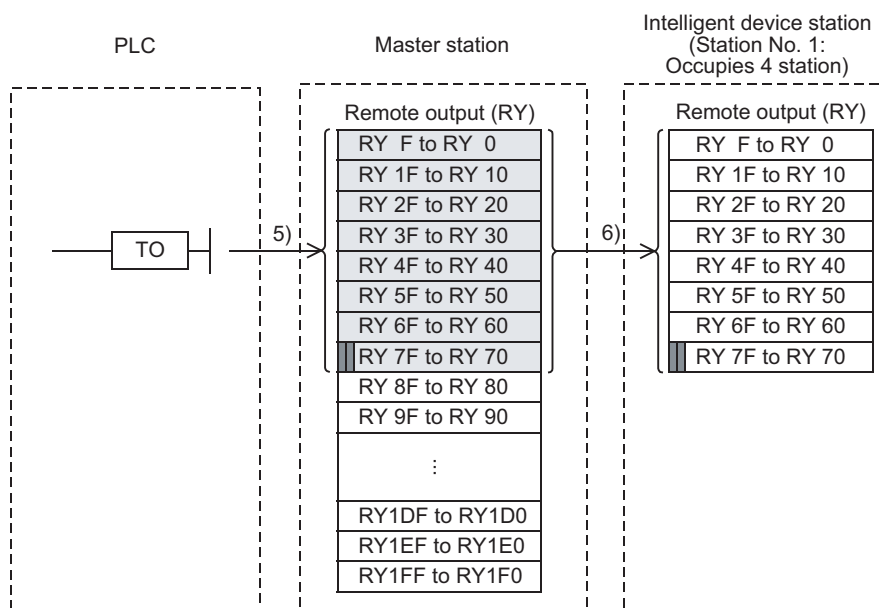

■ : The last 2 bits cannot be used in the communication between the master and intelligent device stations.
(In the example above, RY7E and RY7F cannot be used.)

Write to remote register (RWw)

- 5) The PLC writes the transmission data to the buffer memory "remote register (RWw)" using the TO instruction.
- 6) The data stored in the buffer memory "remote register (RWw)" is automatically (for each link scan) transmitted to the remote register (RWw) in the intelligent device stations.

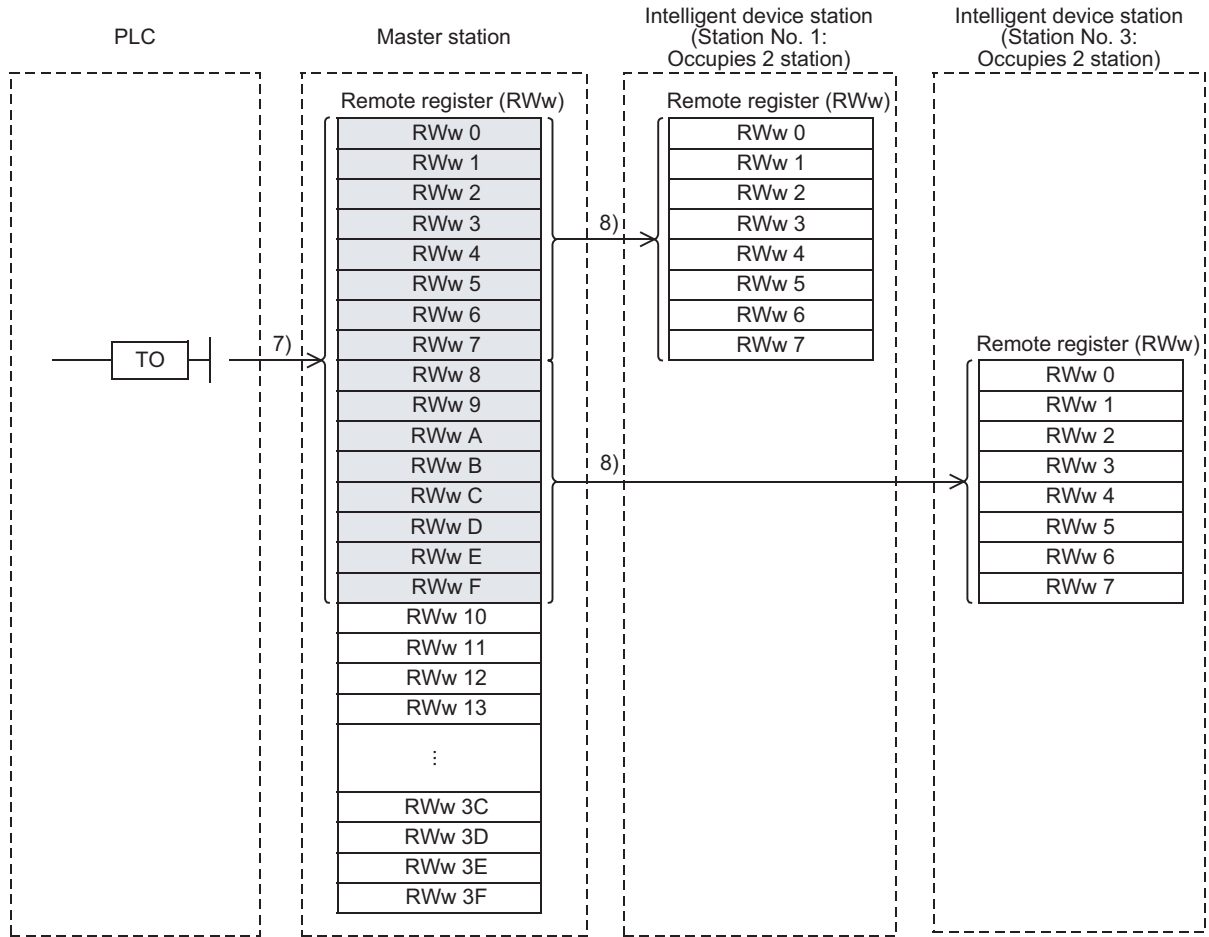

1	Introduction
2	Specification
3	System Configuration
4	Installation
5	Wiring
6	Introduction of Functions
7	Data Link Processing Time
8	Parameter Setting
9	Data Link Procedure
10	Buffer Memory

Read from remote register (RWr)

- 7) The data of the remote register (RWr) in the intelligent device stations is automatically (for each link scan) stored in the buffer memory "remote register (RWr)" in the master station.
- 8) The PLC receives the data of the remote register (RWr) in the intelligent device stations stored in the buffer memory "remote register (RWr)" using the FROM instruction.

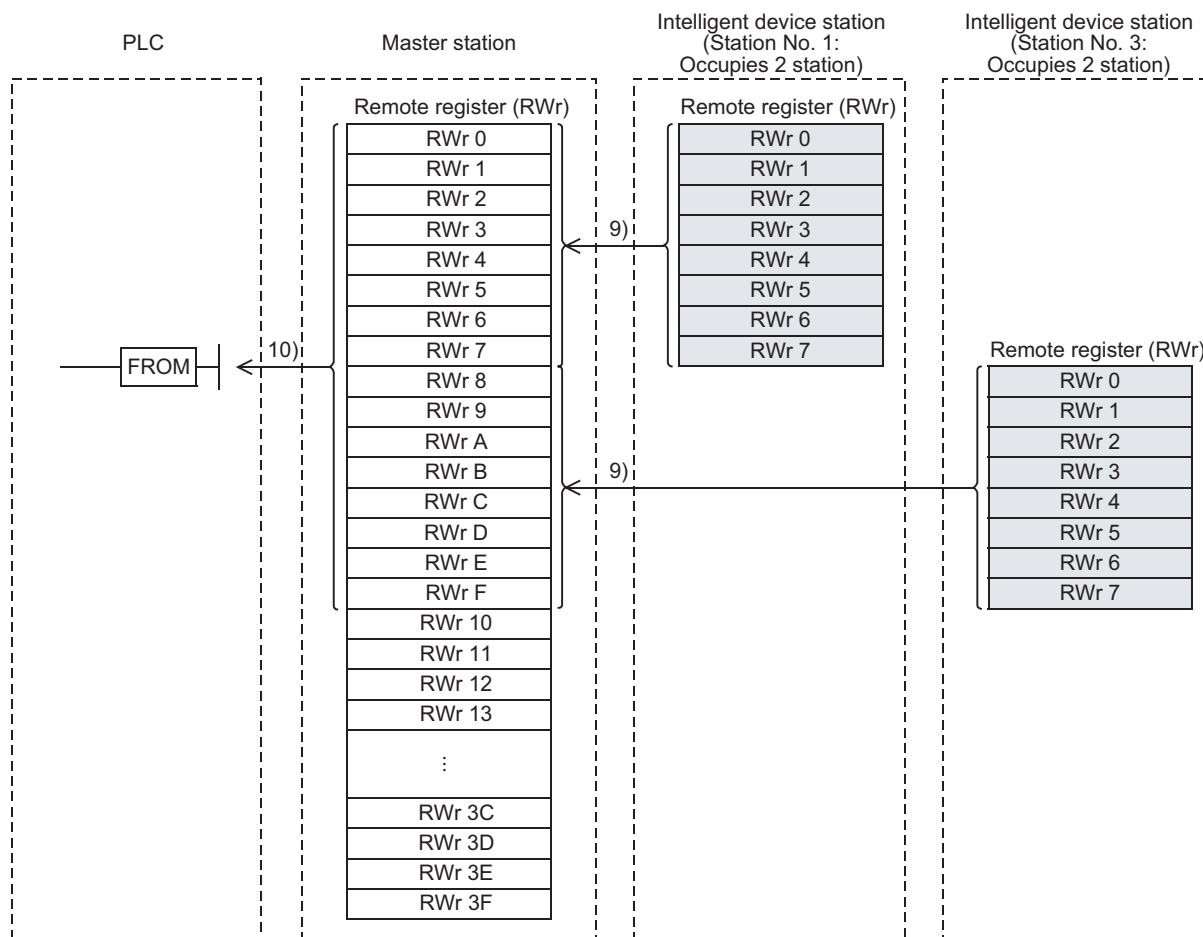

6.2.4 Communication in compound system

This section describes the overview of the communication in the system in which remote I/O stations, remote device stations and intelligent device station exist together.

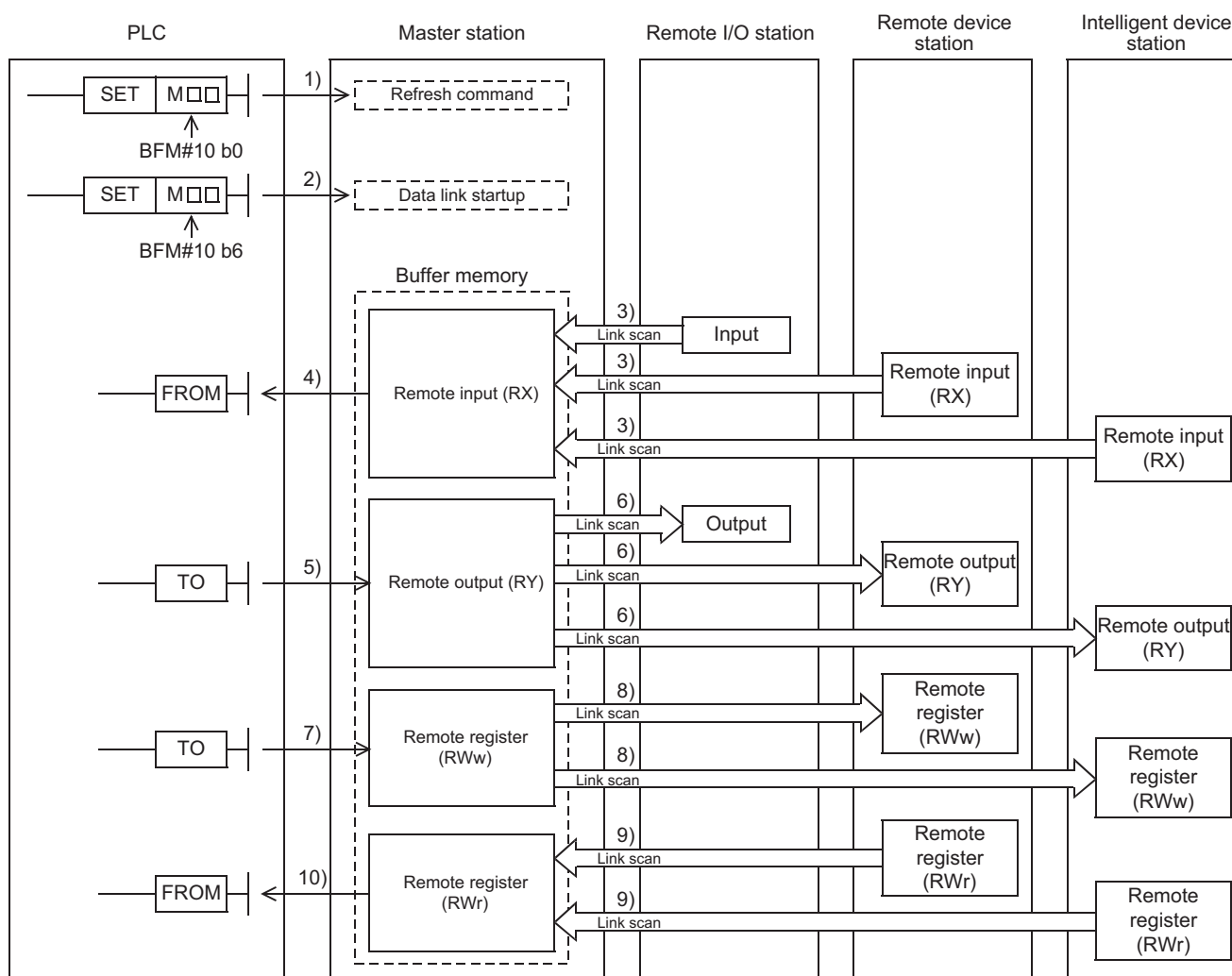

Data link startup

Two methods are available to start up data link, one method using buffer memories and another method using network parameters.

- Data link startup method using buffer memories

- 1) The PLC sets to ON the write refresh command (BFM#10 b0), and makes the data of the remote output (RY) effective.
When the write refresh command (BFM#10 b0) is OFF, all data of the remote output (RY) is treated as "0 (OFF)".
- 2) The PLC sets to ON the write data link startup by buffer memory parameters (BFM#10 b6) to start the data link.
When the data link starts normally, the read data link status in master station (BFM#10 b1) turns ON.

- Data link startup method using network parameters

Set network parameters to the main unit using GX Works2.

When network parameters are set, data link is automatically started up. (Data link startup processing is not required.)

Refer to Chapter 8 for network parameters.

Caution

Do not execute the data link startup method using buffer memories and data link startup method using network parameters at the same time.

1

Introduction

2

Specification

3

System Configuration

4

Installation

5

Wiring

6

Introduction of Functions

7

Data Link Processing Time

8

Parameter Setting

9

Data Link Procedure

10

Buffer Memory

ON/OFF information from the remote I/O station/remote device station/intelligent device station to the master station

- 1) The input status of the input (X) in the remote I/O station and the remote input (RX) in the remote device station/intelligent device station is automatically (for each link scan) stored in the buffer memory "remote input (RX)" in the master station.
- 2) The PLC receives the input status stored in the buffer memory "remote input (RX)" using the FROM instruction.

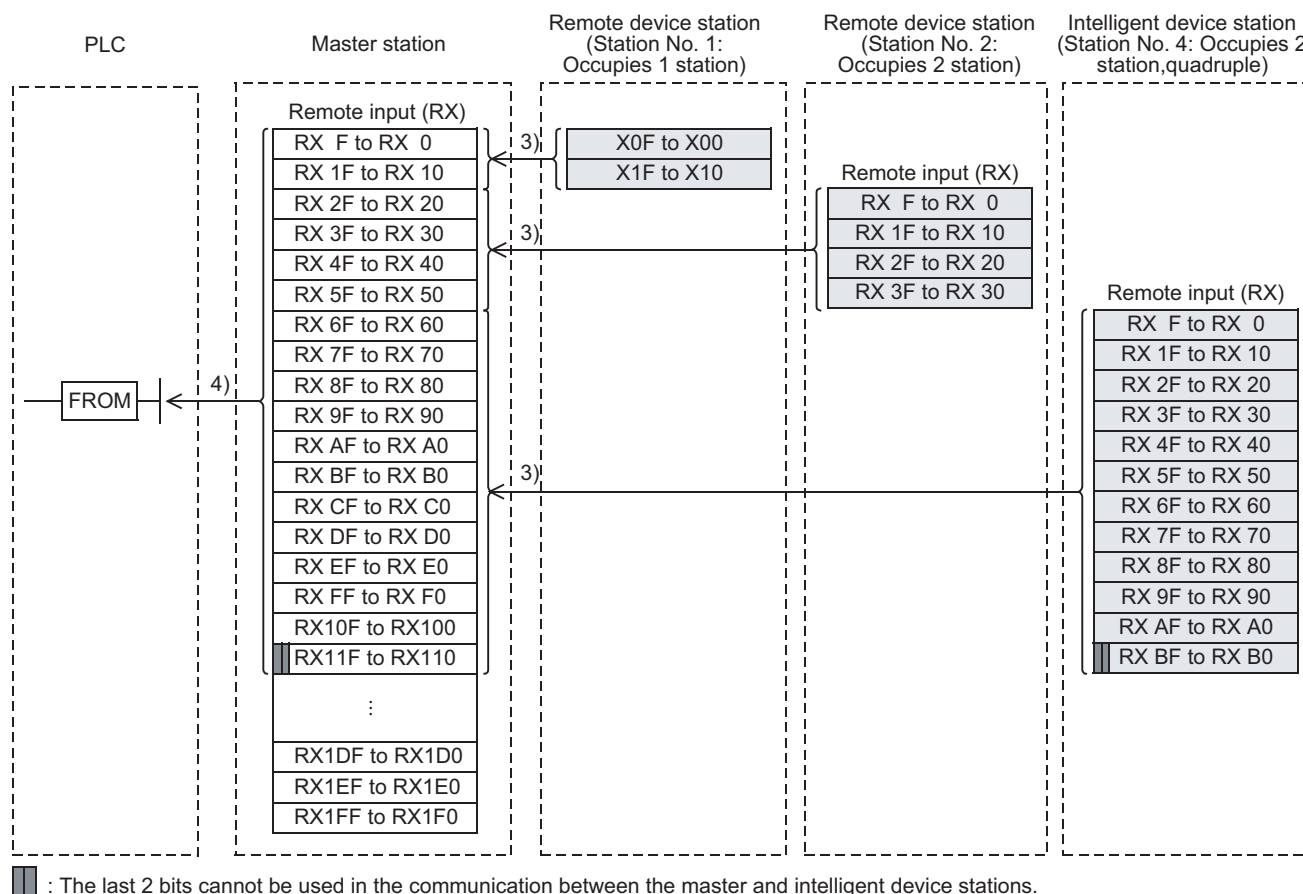

ON/OFF information from the master station to the remote I/O station/remote device station/intelligent device station

- 3) The PLC writes the ON/OFF information to be transmitted to the remote I/O station, the remote device station and the intelligent device station to the buffer memory "remote output (RY)" in the master station using the TO instruction.
- 4) The output status of the buffer memory "remote output (RY)" in the master station is automatically (for each link scan) transmitted to the output (RY) in the remote I/O station and the remote output (RY) in the remote device station and intelligent device station.

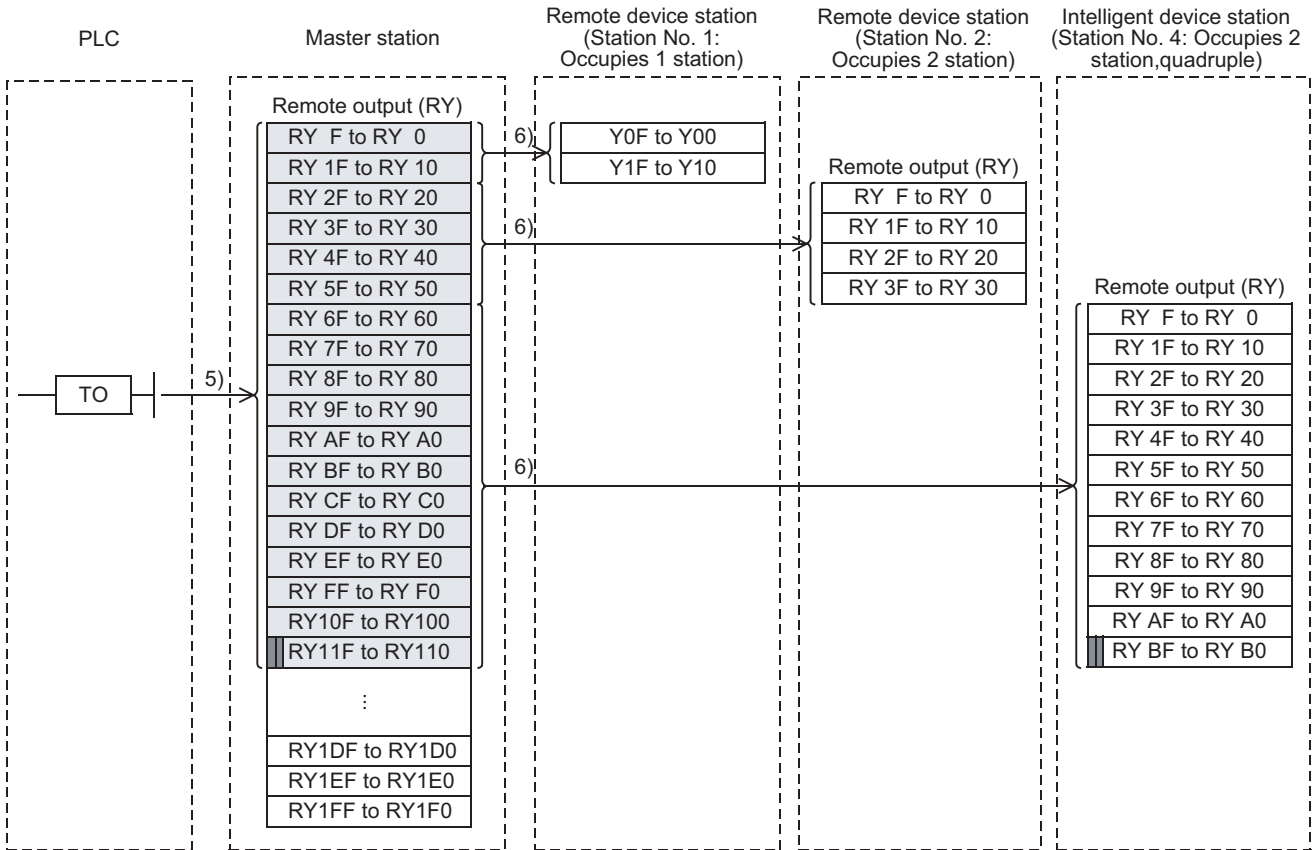

▬ : The last 2 bits cannot be used in the communication between the master and intelligent device stations.

1	Introduction
2	Specification
3	System Configuration
4	Installation
5	Wiring
6	Introduction of Functions
7	Data Link Processing Time
8	Parameter Setting
9	Data Link Procedure
10	Buffer Memory

Word information from the master station to the remote device station/intelligent device station

- 5) The PLC writes the word information to be transmitted to the remote device station and the intelligent device station to the buffer memory "remote register (RWw)" in the master station using the TO instruction.
- 6) The information of the buffer memory "remote register (RWw)" is automatically (for each link scan) stored in the remote register (RWw) in the remote device station and the intelligent device station.

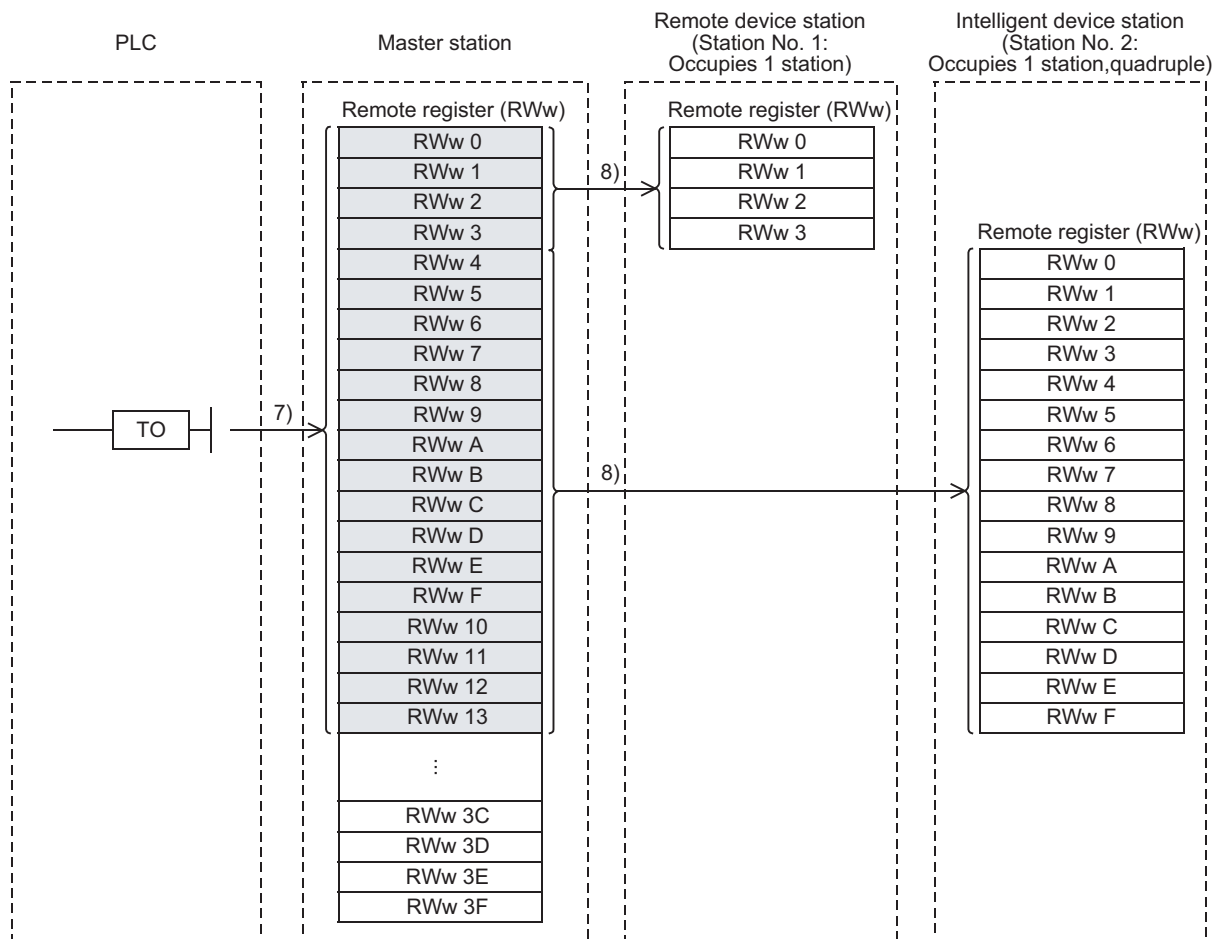

Word information from the remote device station/intelligent device station to the master station

- 7) The data of the remote register (RWr) in the remote device station and the intelligent device station is automatically (for each link scan) stored in the remote register (RWr) in the master station.
- 8) The PLC receives the data of the remote device station and the intelligent device station stored in the buffer memory "remote register (RWr)" using the FROM instruction.

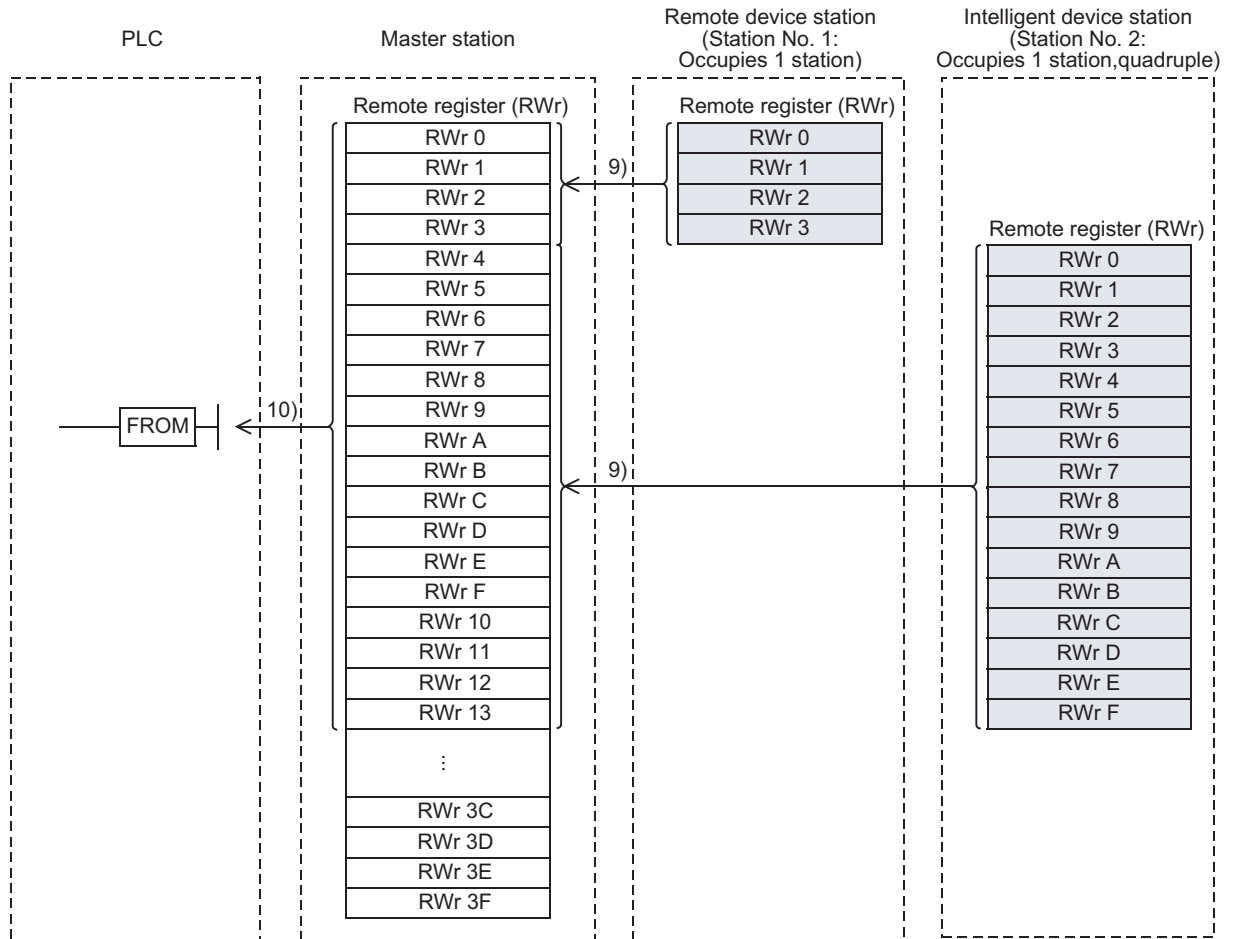

1	Introduction
2	Specification
3	System Configuration
4	Installation
5	Wiring
6	Introduction of Functions
7	Data Link Processing Time
8	Parameter Setting
9	Data Link Procedure
10	Buffer Memory

6.2.5 Network parameter setting with GX Works2

Using GX Works2 makes the setting of network parameters easier.

Make sure to turn OFF the power of the PLC once, and then turn it ON again after changing network parameters and transferring them.

The data link is automatically started if GX Works2 is used to set the parameters. Data link startup processing using buffer memories is not required.

Sequence programs for parameter setting are not required, either.

Refer to Section 3.2 for applicable PLCs and GX Works2 versions.

Refer to Chapter 8 for details of network parameters.

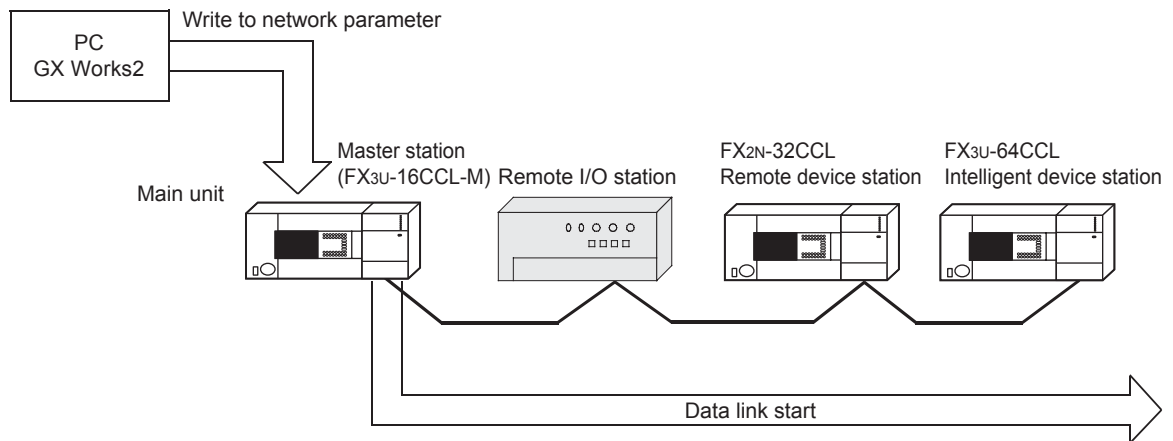

Caution

Do not execute the data link startup method using buffer memories and data link startup method using network parameters at the same time.

6.3 RAS Function

The term "RAS" stands for "reliability, availability and serviceability", and refers to the total operability of an automated facility.

6.3.1 Slave station cutoff function

This function cuts off only remote stations and intelligent device stations in which data link is disabled by power OFF, etc., and continues the data link using only normal remote stations and intelligent device stations. No setting is required.

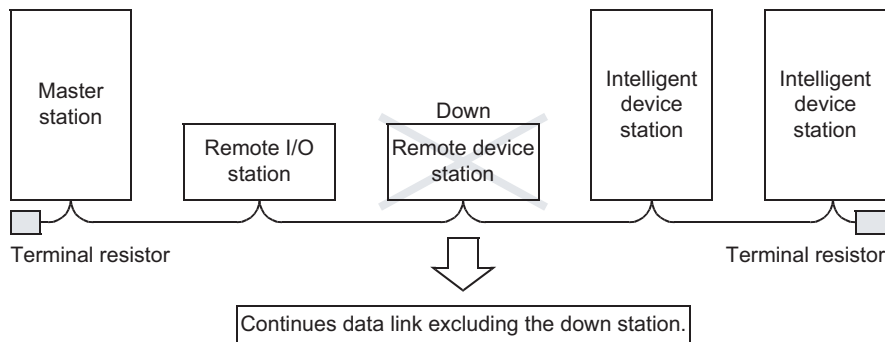

Caution

When a cable is broken, the data link is disabled in the entire system because terminal resistors do not function any more.

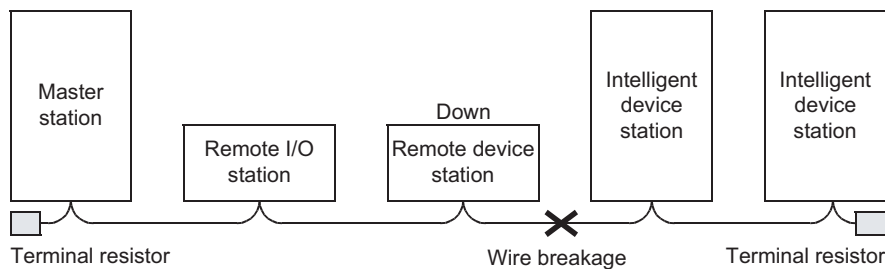

6.3.2 Automatic return function

This function allows a module which was disconnected from the data link by power OFF, etc. to automatically join the data link again when it recovers the normal status.

1. Setting method

- When using a sequence program
 - Set the operation status to the parameter information area "Number of automatic return units (BFM#3)" in the buffer memory in the master station.
 - Set the number of remote stations and intelligent device stations that can return to the system during one link scan. The setting range is "1 to 10 (units)".
- When using network parameters
 - Set automatic return using the network parameter "Automatic Reconnection Station Count" with GX Works2.
 - Refer to Section 8.5 for the setting method.

1	Introduction
2	Specification
3	System Configuration
4	Installation
5	Wiring
6	Introduction of Functions
7	Data Link Processing Time
8	Parameter Setting
9	Data Link Procedure
10	Buffer Memory

6.3.3 Data link status setting against error in master station PLC

This function sets the data link status for a case in which an operation stop error occurs in the master station PLC.

1. Setting method

- When using a sequence program
Set the operation status to the parameter information area "Operation specification when CPU is down (BFM#6)" in the buffer memory in the master station.
0: Stop
1: Continue
- When using network parameters
Set automatic return using the network parameter "PLC Down Select" with GX Works2.
Refer to Section 8.5 for the setting method.

Caution

Even if an operation continue error occurs in the master station PLC, the data link continues.

6.3.4 Setting of input data status from data link faulty station

The status of the data input (received) from a data link faulty station can be set.

→ For the status of each station when an error has occurred, refer to Section 7.3.

1. Target input (received) data

The figure below shows the buffer memory area regarded as the setting target.

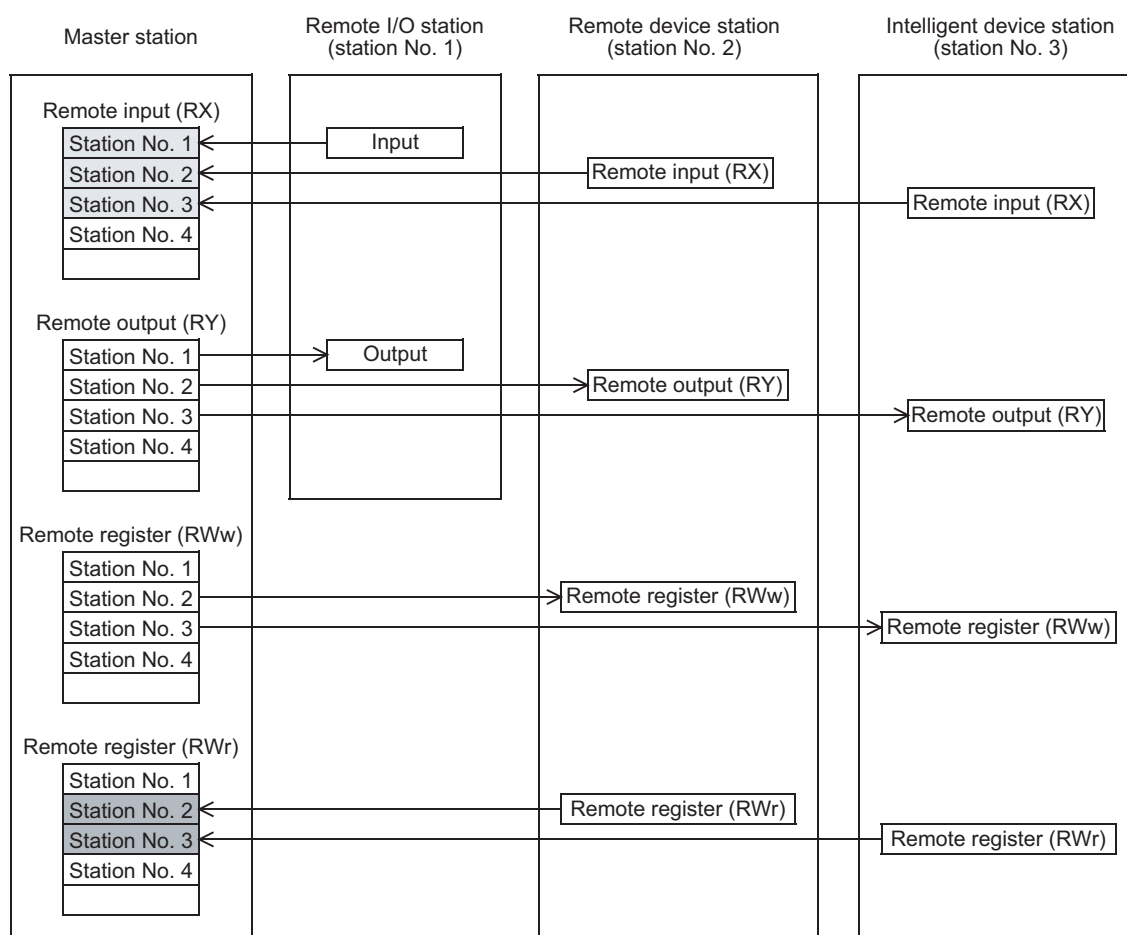

□ : Target area of clear/keep
 ■ : Area kept without regard to the setting

- The remote input (RX) in the master station clear or retain data from faulty stations according to the setting.
- The remote register (RWr) in the master station retain data from faulty stations regardless of the setting.

2. Setting method

- When using a sequence program
 Set the operation status to the parameter information area "Data link disorder station setting (BFM#12)" in the buffer memory in the master station.
 0: Hold (Keeps the status right before error)
 1: Clear
- When using network parameters
 Set automatic return using the network parameter "Operation Setting" with GX Works2.
 Refer to Section 8.5 for the setting method.

Caution

When the data link faulty station is set as an error invalid station, input data (remote input (RX)) from that station is retained regardless of the setting.

1	Introduction
2	Specification
3	System Configuration
4	Installation
5	Wiring
6	Introduction of Functions
7	Data Link Processing Time
8	Parameter Setting
9	Data Link Procedure
10	Buffer Memory

6.3.5 Slave station refresh/compulsory clear setting in case of programmable controller CPU STOP

This function compulsorily clears output (send) data to slave stations when the PLC CPU enters STOP mode.
→ For the status of each station when an error has occurred, refer to Section 7.3.

1. Target output (send) data

The figure below shows the buffer memory area regarded as the setting target.

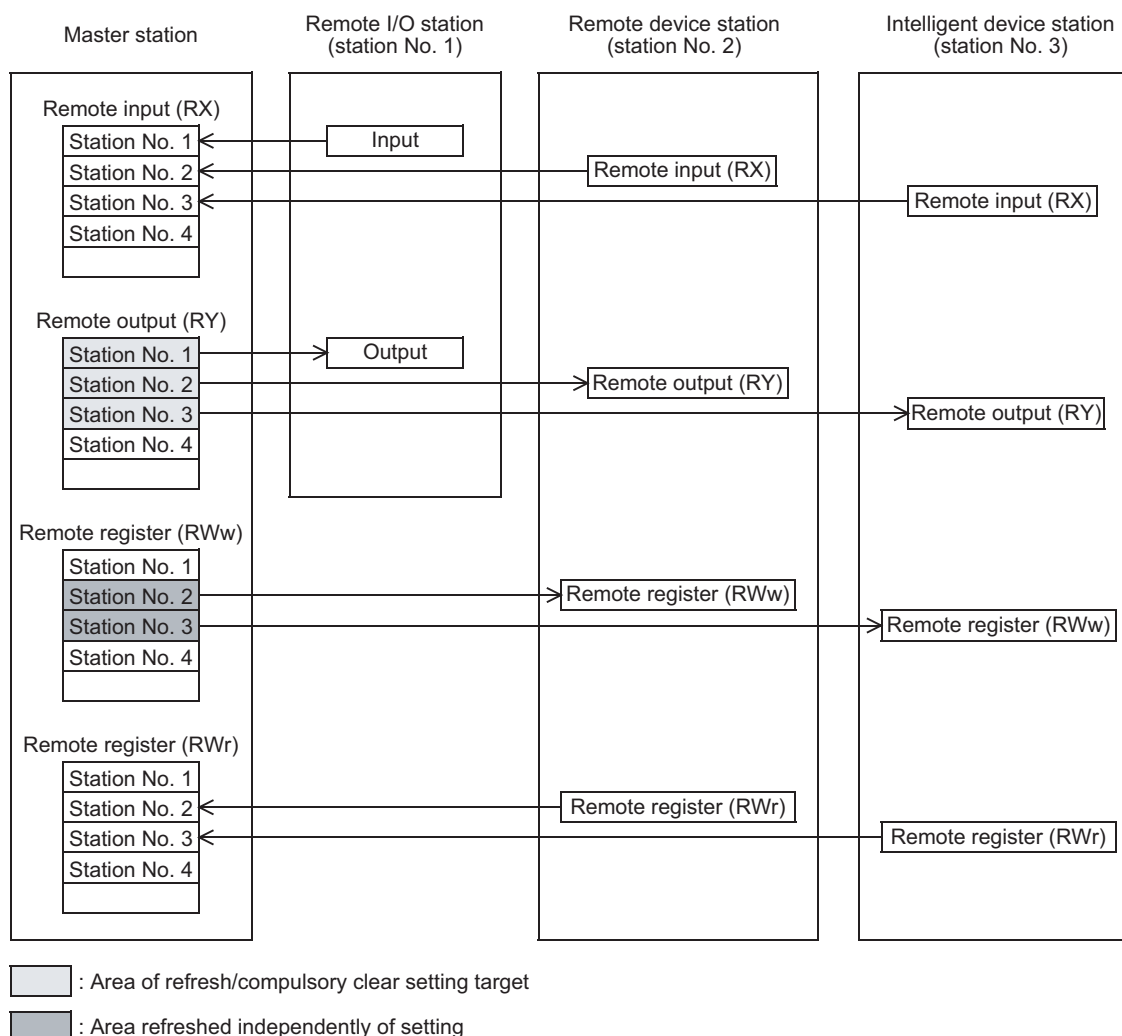

- The remote output (RY) is refreshed or compulsorily cleared according to the setting when the master station PLC CPUs come to STOP.
- The remote register (RWw) is refreshed regardless of the setting when the master station PLC CPUs come to STOP.

2. Setting method

- When using a sequence program
 - Set the operation status to the parameter information area "Case of CPU STOP setting (BFM#13)" in the buffer memory in the master station.
 - 0: Refresh
 - 1: Clears compulsorily
- When using network parameters
 - Set automatic return using the network parameter "Operation Setting" with GX Works2.
 - Refer to Section 8.5 for the setting method.

6.3.6 Consistency control function

Use these buffer memory addresses for consistency control to send or receive link data composed of 1 word (16 bits) or more or 2 words (32 bits) or more.

These buffer memory addresses assure data consistency for 1 word (16 bits) or more when read or written by the FROM/TO instructions, or data consistency for 2 words (32 bits) or more when read or written by the DFROM/DTO instructions.

BFM No.		Description	Explanation
Hex.	Dec.		
#DCH	#220	RX area consistency flag	Consistency control 1: Consistency accessibility start Set the latest data, and stop the buffer memory from being refreshed. 0: Data consistency accessibility is completed or not used. ("0" is the initial value.)
#DDH	#221	RY area consistency flag	
#DEH	#222	RWw area consistency flag	
#DFH	#223	RWr area consistency flag	Refresh the communication data and buffer memory as required. (When a device changes from "1" to "0", the unit resumes refreshing the communication data and buffer memory.) When any other number is set, these devices do not control the consistency in the same way as "0".

Consistency control operation examples and a sequence program example are as follows:

1. Explanation of RX and RWr consistency flag operation

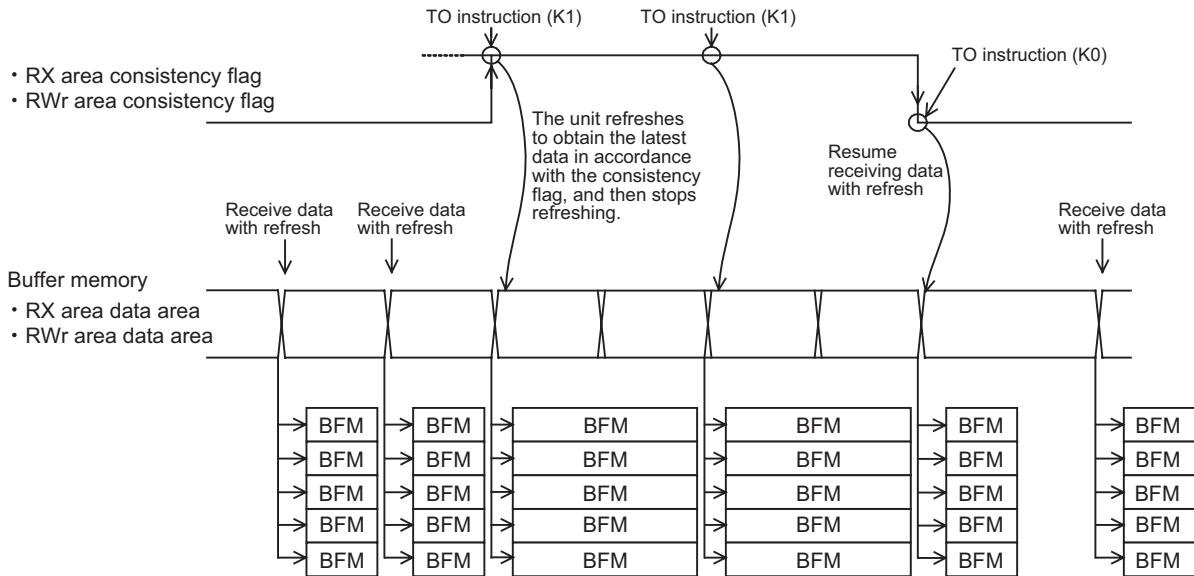

2. Explanation of RY and RWw consistency flag operation

- RY area consistency flag
- RWw area consistency flag

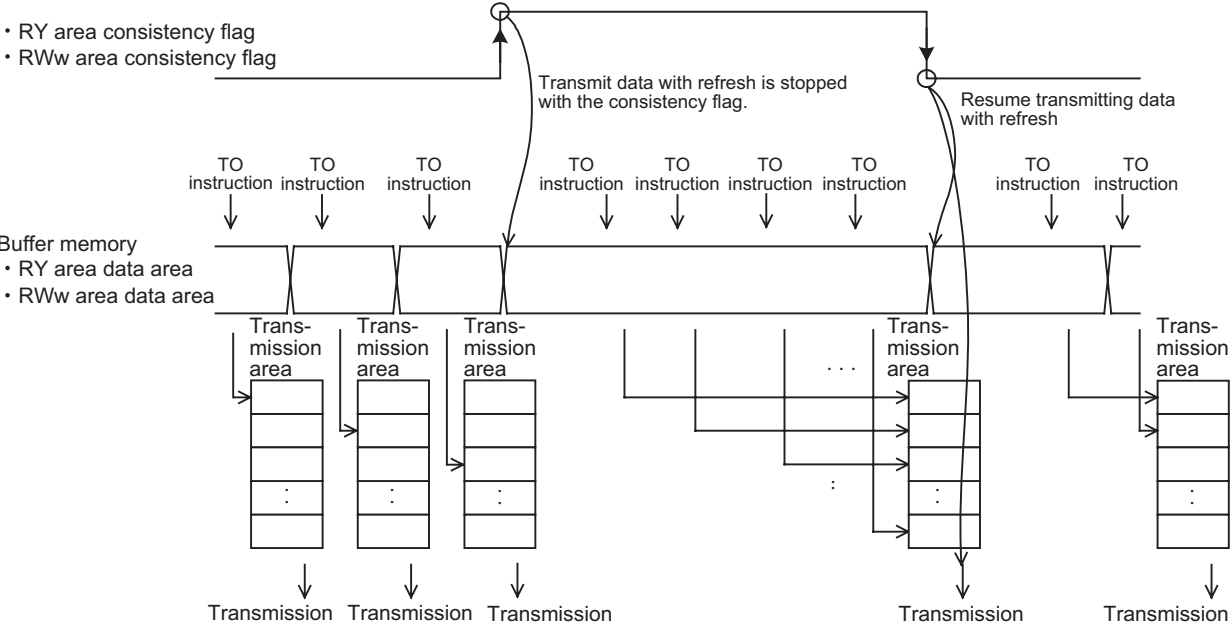

3. Sequence program example

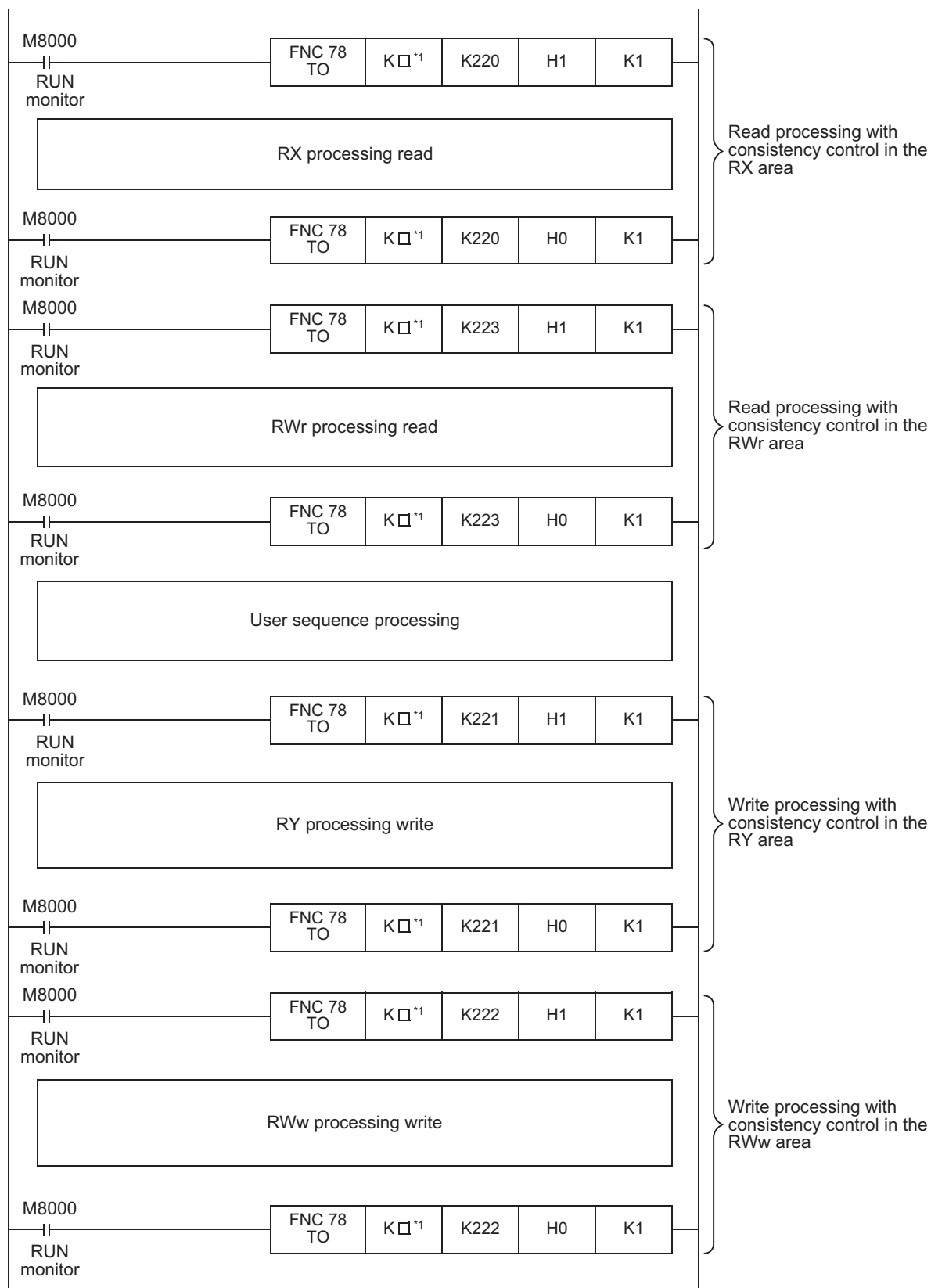

*1. □: Unit No. of FX3U-16CCL-M enters.

1	Introduction
2	Specification
3	System Configuration
4	Installation
5	Wiring
6	Introduction of Functions
7	Data Link Processing Time
8	Parameter Setting
9	Data Link Procedure
10	Buffer Memory

6.4 Handy Functions

6.4.1 Remote device station initialization procedure registration function

Set the initial setting of remote device stations using network parameters with GX Works2, and register it to the main unit.

The FX3U-16CCL-M instructs registration of remote device station initialization procedure, and then stores the number of the currently executing procedure to the buffer memory. For this reason, when processing has stopped, the relevant information such as the procedure number or target station number can be confirmed. When an operating remote device station is replaced due to failure, only the replaced remote device station can be specified and initialized. Remote device stations other than the specified station continue to operate.

For the availability of this function, refer to the manuals of the remote device stations to be used.

Refer to Section 3.2 for applicable PLCs and GX Works2 versions.

1. Number of setting items for remote device station initialization procedure registration

Remote device station initialization procedure registration can be executed up to 16 items per remote device station. If setting 17 items or more is necessary, execute initial setting with the sequence program.

Caution

- Remote device station initialization procedure registration and initial settings with the sequence program cannot be executed at the same time. If they are executed at the same time, remote device station may malfunction.
- Initial settings can be set for up to 8 remote device stations.

2. Remote device station initialization procedure setting method

Set the initialization procedure using the network parameter "Remote Device Station Initial Setting" with GX Works2.

- 1) In "Target Station No.", set the station number of the unit for which the initial settings are to be performed.

	Target Station No.	No. of Registered Procedures	Regist Procedure
1			Regist Procedure
2			Regist Procedure
3			Regist Procedure
4			Regist Procedure
5			Regist Procedure
6			Regist Procedure
7			Regist Procedure
8			Regist Procedure

Clear Check End Cancel

Set item	Contents of setting
Target Station No.	Set the station number of the unit to be initialized. [Setting range] 1 to 16
No. of Registered Procedures	Displays the number of procedures registered on the procedure registration screen.
Regist Procedure	Switches to the procedure registration screen when the target station number is set within the setting range.

2) Set the initial setting procedure in "Regist Procedure".

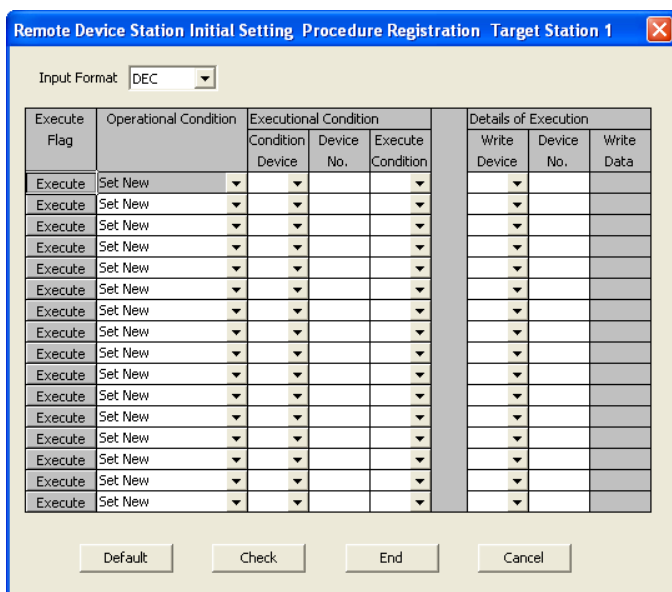

Set item		Contents of setting
Input Format		Select the data input format and display format of "Write Data" when "Write Device" in "Details of Execution" is set to "RWw". (Default: DEC) • DEC • HEX
Execute Flag		Set whether or not the initial setting is to be actually executed. (Default: Execute) • Execute • Only Set
Operational Condition		Select whether the initial setting operation condition is to be set anew or same as the previous condition. (Default: Set New) • Set New • Same as Prev. Set
Execuational Condition	Condition Device	Select the device used as the initial setting execution condition. • RX • SB
	Device No.	Set the device number used as the initial setting execution condition. [Setting range] • When "Condition Device" is set to "RX" Remote Net(Ver.1 Mode): 00 to 7FH Remote Net(Ver.2 Mode), Remote Net(Additional Mode): 00 to DFH • When "Condition Device" is set to "SB" Remote Net(Ver.1 Mode): 00 to FFH Remote Net(Ver.2 Mode), Remote Net(Additional Mode): 00 to 1FFH
	Execute Condition	Select the initial setting execution condition. • ON • OFF
Details of Execution	Write Device	Select the device to which the initial setting execution contents are written. • RY • RWw
	Device No.	Select the device number to which the initial setting execution contents are written. [Setting range] • When "Write Device" is set to "RY" Remote Net(Ver.1 Mode): 00 to 7FH Remote Net(Ver.2 Mode), Remote Net(Additional Mode): 00 to DFH • When "Write Device" is set to "RWw" Remote Net(Ver.1 Mode): 00 to FH Remote Net(Ver.2 Mode), Remote Net(Additional Mode): 00 to 1FH
	Write Data	Set the contents of the initial settings. [Setting range] • When "Write Device" is set to "RY" Select "ON" or "OFF". • When "Write Device" is set to "RWw" 0 to 65535 (DEC), 0 to FFFFH (HEX)

1	Introduction
2	Specification
3	System Configuration
4	Installation
5	Wiring
6	Introduction of Functions
7	Data Link Processing Time
8	Parameter Setting
9	Data Link Procedure
10	Buffer Memory

3. Method for initializing only a specified station (specification of remote device station to be initialized)

When an operating remote device station is replaced due to failure, only the replaced remote device station can be specified and initialized. Remote device stations other than the specified station continue their operations.

1) How to specify the remote device station to be initialized

Set the station to be initialized in the "specification of remote device station to be initialized (SW0014)" in the link special register (SW).

To set this, turn ON the bit corresponding to the specified station number within SW0014 (only the bit of the head station number). When all bits are OFF, initial processing is performed on all stations that are set in the "Remote Device Station Initial Setting" in the Network Parameter setting.

The table below shows the link special register (SW0014) configuration. (Numbers 1 to 16 indicate station numbers)

SW No.	BFM No.		b15	b14	b13	b12	b11	b10	b9	b8	b7	b6	b5	b4	b3	b2	b1	b0
	Hex.	Dec.																
SW0014	#614H	#1556	16	15	14	13	12	11	10	9	8	7	6	5	4	3	2	1

4. Enable initial settings

Before creating a program for communication with remote device stations, create a program to enable the initial settings using remote device station initialization procedure registration instruction (SB000D) and completion status of remote device station initialization procedure execution (SB005F).

[Procedure for the remote device station initialization procedure registration]

- 1) Turn SB000D ON, and start to execute the registered initial setting.
During execution of initial processing, remote device station initialization procedure execution status (SB005E) stays ON. Also, the execution procedure numbers and target station numbers of the registration are stored to remote device station initialization procedure registration execution individual information (SW0110 to SW0117).
- 2) When initial processing of all preset stations is completed, SB005F turns ON. Also, the execution result is stored to remote device station initialization procedure instruction result (SW005F).
The execution procedure numbers in SW0110 to SW0117 become FF00H.
- 3) When SB000D is turned OFF on completion of initial processing (SB005F : ON), SB005F, and SW0110 to SW0117 are cleared.

The following shows operation of the link special relays and link special registers when remote device station initialization procedure registration is performed.

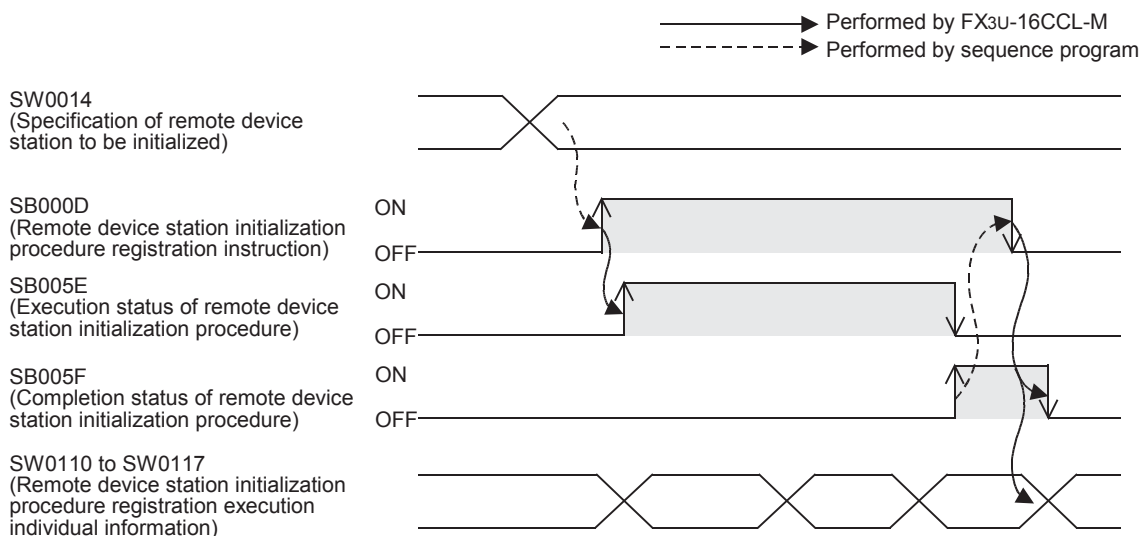

5. Preparation for communication with remote device stations

- 1) Register network parameters and the program created in step 4 above to the main unit.
- 2) Turn OFF the power of the main unit, and then turn it ON again.
- 3) Instruct the master station to register the remote device station initialization procedure.

Caution

- While the remote device station initialization procedure registration instruction (SB000D) is on, the refresh of the remote input/output and remote registers stops.
- When the remote device station initialization procedure registration instruction (SB000D) turns OFF after completion of the initial processing, all of RY signals that have turned ON during the initial processing turn OFF. Therefore, for signals that should be kept ON, turn them ON in the program.
- The remote device station initialization procedure registration completion status (SB005F) does not turn ON unless all of initial processing for the stations specified in the remote device station initialization procedure registration station specification (SW0014) is completed normally. If any error station exists, turn OFF the remote device station initialization procedure registration instruction (SB000D) depending on the status of the other stations.

6. Associated link special relays/link special registers (SB/SW)

The table below shows link special relays and registers related to the remote device station initialization procedure registration function.

- Link special relay (SB)

SB No.	BFM No.			Name	Description
	Hex.	Dec.	Bit		
SB000D	5E0H	1504	b13	Remote device station initialization procedure registration instruction	Starts the initial processing using the information registered during the initialization procedure registration. While SB000D is on, the refresh of the remote input/output and remote registers stops. OFF: Not instructed ON : Instructed
SB005E	5E5H	1509	b14	Execution status of remote device station initialization procedure	Indicates the execution status of the initialization procedure. OFF: Not executed ON : Being executed
SB005F	5E5H	1509	b15	Completion status of remote device station initialization procedure	Indicates the completion status of the initialization procedure execution. OFF: Not completed ON : Completed

- Link special register (SW)

SW No.	BFM No.		Name	Description																		
	Hex.	Dec.																				
SW0014	614H	1556	Specification of remote device station to be initialized	Specifies the station to be initialized using the information saved in initialization procedure registration. 0: Initial processing not performed 1: Initial processing performed <table border="1" style="margin-left: 20px;"> <tr> <td>b15</td><td>b14</td><td>b13</td><td>b12</td><td>to</td><td>b3</td><td>b2</td><td>b1</td><td>b0</td> </tr> <tr> <td>16</td><td>15</td><td>14</td><td>13</td><td>to</td><td>4</td><td>3</td><td>2</td><td>1</td> </tr> </table> Numbers 1 to 16 above indicate station numbers. (Only the bit corresponding to the head station number is set to ON.) Error invalid stations, reserved stations and any station of the number higher than the max. are not specified.	b15	b14	b13	b12	to	b3	b2	b1	b0	16	15	14	13	to	4	3	2	1
b15	b14	b13	b12	to	b3	b2	b1	b0														
16	15	14	13	to	4	3	2	1														
SW005F	65FH	1631	Remote device station initialization procedure registration instruction result	Stores the execution result of the initialization procedure registration instruction with SB000D. 0: Normal Other than 0: Stores the error code (Refer to Section 16.3.).																		
SW0110 to SW0117	710H to 717H	1808 to 1815	Remote device station initialization procedure registration execution individual information (target 1 to 8)	The execution phase of initialization procedure registration is stored. Upper bit: Next execution procedure number (FFH at completion) Lower bit: Targeted station number																		

1

Introduction

2

Specification

3

System Configuration

4

Installation

5

Wiring

6

Introduction of Functions

7

Data Link Processing Time

8

Parameter Setting

9

Data Link Procedure

10

Buffer Memory

6.4.2 Reserved station function

This function sets remote stations and intelligent device station to be connected in the future (which are not currently connected) as reserved ones so that such stations are not handled as data link faulty stations.

1. Setting method

- When using a sequence program

Set the operation status to the parameter information area "Reserved station specification (BFM#16)" in the buffer memory in the master station.

Set to ON the bits corresponding to the station numbers of the stations to be reserved.

The table below shows the buffer memory configuration. (Numbers 1 to 16 indicate station numbers)

BFM No.		b15	b14	b13	b12	b11	b10	b9	b8	b7	b6	b5	b4	b3	b2	b1	b0
Hex.	Dec.																
#10H	#16	16	15	14	13	12	11	10	9	8	7	6	5	4	3	2	1

- When using network parameters

Set reserved stations using the network parameter "Station Information Setting" with GX Works2.

Refer to Section 8.5 for the setting method.

2. Setting example

1) System configuration example

When one remote I/O station and two remote device stations are to be connected in the future to the system in which one intelligent device station and one remote I/O station are connected

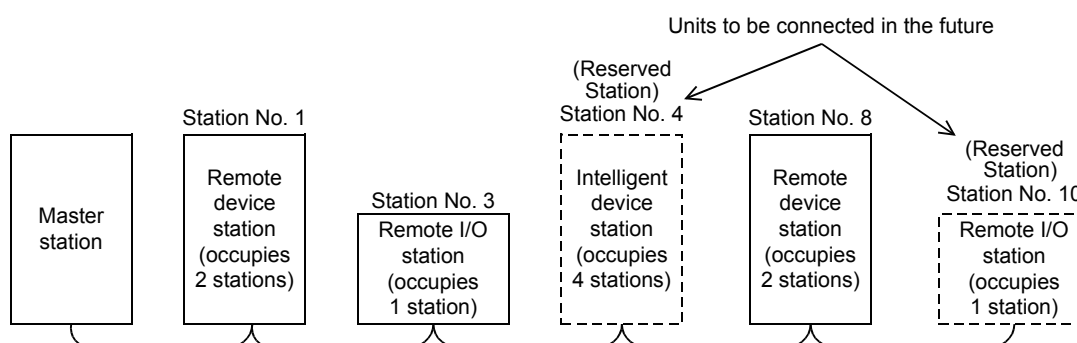

2) Buffer memory setting example

Set to ON the 3rd bit corresponding to the station No. 4 and the 9th bit corresponding to the station No. 10. (Set "0208H" to the BFM#16.)

BFM No.		b15	b14	b13	b12	b11	b10	b9	b8	b7	b6	b5	b4	b3	b2	b1	b0
Hex.	Dec.																
#10H	#16	0	0	0	0	0	0	1	0	0	0	0	0	1	0	0	0
								2							8		

Caution

- When a connected remote station or intelligent device station is set as a reserved station, the station cannot execute any data link at all.
- For a remote station or intelligent device station which occupies 2 or more stations, turn on only the bit for the station number set by the unit's station number setting switch.

6.4.3 Error invalid station function

This function sets remote station and intelligent device station in which data link is disabled by power OFF, etc. as error invalid stations so that such stations are not handled as data link faulty stations.

1. Setting method

- When using a sequence program

Set the operation status to the parameter information area "Error invalid station specification (BFM#20)" in the buffer memory in the master station.

Set the bits corresponding to the station numbers of the stations to be made invalid to ON. However, for a remote station occupying two or more stations, set to ON only the bit corresponding to the station number set by the station number (head station number) setting switch in the unit.

The table below shows the buffer memory configuration. (Numbers 1 to 16 indicate station numbers)

BFM No.		b15	b14	b13	b12	b11	b10	b9	b8	b7	b6	b5	b4	b3	b2	b1	b0
Hex.	Dec.																
#14H	#20	16	15	14	13	12	11	10	9	8	7	6	5	4	3	2	1

- When using network parameters

Set reserved stations using the network parameter "Station Information Setting" with GX Works2. Refer to Section 8.5 for the setting method.

2. Setting example

- System configuration example

When the remote I/O station No. 3 and the intelligent device station No. 7 are made invalid in the system in which two remote I/O stations, two remote device stations and one intelligent device station are connected

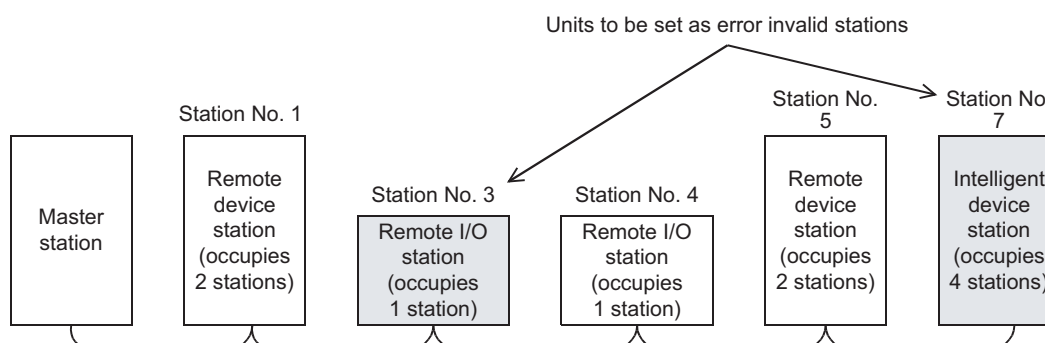

- Buffer memory setting example

Set to ON the 2nd bit corresponding to the station No. 3 and the 6th bit corresponding to the station No. 7. (Set "0044H" to the BFM#20.)

BFM No.		b15	b14	b13	b12	b11	b10	b9	b8	b7	b6	b5	b4	b3	b2	b1	b0
Hex.	Dec.																
#14H	#20	0	0	0	0	0	0	0	0	0	1	0	0	0	1	0	0
		0				0				4				4			

Caution

- For errors will not be detected at all in stations set as invalid stations.
- If a remote stations and intelligent device stations set as invalid station is also set as reserved station, the reserved station function has the priority.
- For a remote station or intelligent device station which occupies 2 or more stations, turn on only the bit for the station number set by the unit's station number setting switch.
- The error invalid station setting cannot be changed while online.

6.4.4 Temporary Error Invalid Station Specification Function

This function prevents remote stations and intelligent device stations that are designated not to be treated as "data link faulty stations" while online.

It allows the replacement of modules while online without error detection.

Different from the error invalid station specification by parameter setting, temporary error invalid stations can be temporarily specified with arbitrary timing.

Refer to Subsection 16.4.5 for the temporary error invalid station specification method using GX Works2.

1. I/O status when temporary error invalid stations are specified

In a station specified as a temporary error invalid station, all cyclic transmission data is refreshed.

2. Temporary error invalid station specification procedure

- 1) Select whether two or more stations are to be specified as temporary error invalid stations. (SW0003)
 - 0: Two or more stations
 - 01 to 16: One station
- 2) Set to ON the request for temporary error invalid stations. (SB0004)
- 3) Turn OFF the power of temporary error invalid stations, and replace them.
- 4) Turn ON the power of temporary error invalid stations.
- 5) Set to ON the request to cancel the setting of temporary error invalid stations. (SB0005)

Caution

- Even if the request for a temporary error invalid station is executed for a faulty station, the error information is not cleared. The temporary error invalid station specification function is effective only for errors which occur after setting.
- The request for setting temporary error invalid stations and the request for canceling of temporary error invalid stations are not effective to stations which are specified as error invalid stations.

3. Associated link special relays/link special registers (SB/SW)

The table below shows link special relays and registers related to the temporary error invalid station specification function.

- Link special relay (SB)

SB No.	BFM No.			Name	Description
	Hex.	Dec.	Bit		
SB0004	5E0H	1504	b4	Request for temporary error invalid station	Determines stations specified by SW0003 or SW0004 as temporary error invalid stations. OFF: Does not give the request. ON : Gives the request.
SB0005	5E0H	1504	b5	Request for cancel of temporary error invalid station	Cancels the stations specified by SW0003 or SW0004 from temporary error invalid stations. OFF: Does not give the request. ON : Gives the request.
SB0048	5E4H	1508	b8	Temporary error invalid station acceptance status	Indicates the temporary error invalid station request acceptance status. OFF: Not accepted ON : Accepted
SB0049	5E4H	1508	b9	Temporary error invalid station completion status	Indicates the temporary error invalid station request acceptance completion status. OFF: Not completed ON : Temporary error invalid stations are determined/ Specified station number is invalid
SB004A	5E4H	1508	b10	Temporary error invalid station completion status	Indicates the temporary error invalid station cancel request acceptance status. OFF: Not accepted ON : Accepted
SB004B	5E4H	1508	b11	Temporary error invalid station cancel acceptance status	Indicates the temporary error invalid station cancel request acceptance completion status. OFF: Not completed ON : Cancel of temporary error invalid stations is completed.

- Link special register (SW)

SW No.	BFM No.		Name	Description																		
	Hex.	Dec.																				
SW0003	603H	1539	Specification of multiple temporary error invalid stations	Selects whether or not to specify two or more temporary error invalid stations. 00: Specifies two or more stations stored in SW0004. 1 to 16: Specifies a single station whose station number is 1 to 16. (The number indicates the station number of a temporary error invalid station.)																		
SW0004	604H	1540	Temporary error invalid station specification	Specifies temporary error invalid stations. 0: Does not specify as temporary error invalid station. 1: Specifies as temporary error invalid station. <table border="1" style="margin-left: 20px;"> <tr> <td>b15</td><td>b14</td><td>b13</td><td>b12</td> <td>to</td> <td>b3</td><td>b2</td><td>b1</td><td>b0</td> </tr> <tr> <td>16</td><td>15</td><td>14</td><td>13</td> <td>to</td> <td>4</td><td>3</td><td>2</td><td>1</td> </tr> </table> Numbers 1 to 16 above indicate station numbers. (Only the bit corresponding to the head station number is set to ON.) Error invalid stations, reserved stations and any station of the number higher than the max. are not specified.	b15	b14	b13	b12	to	b3	b2	b1	b0	16	15	14	13	to	4	3	2	1
b15	b14	b13	b12	to	b3	b2	b1	b0														
16	15	14	13	to	4	3	2	1														
SW0049	649H	1609	Result of request for temporary error invalid stations	Stores the execution result of request for temporary error invalid stations by SB0004. 0: Normal Other than 0: Stores the error code (Refer to Section 16.3.).																		
SW004B	64BH	1611	Result of request for cancel of temporary error invalid stations	Stores the execution result of request for cancel of temporary error invalid stations by SB0005. 0: Normal Other than 0: Stores the error code (Refer to Section 16.3.).																		
SW007C	67CH	1660	Temporary error invalid station specification status	Stores the temporary error invalid station specification status. 0: Normal status 1: Temporary error invalid status <table border="1" style="margin-left: 20px;"> <tr> <td>b15</td><td>b14</td><td>b13</td><td>b12</td> <td>to</td> <td>b3</td><td>b2</td><td>b1</td><td>b0</td> </tr> <tr> <td>16</td><td>15</td><td>14</td><td>13</td> <td>to</td> <td>4</td><td>3</td><td>2</td><td>1</td> </tr> </table> Numbers 1 to 16 above indicate station numbers. (Bits corresponding to as many as the number of occupied stations are set to ON.) Error invalid stations, reserved stations and any station of the number higher than the max. are excepted.	b15	b14	b13	b12	to	b3	b2	b1	b0	16	15	14	13	to	4	3	2	1
b15	b14	b13	b12	to	b3	b2	b1	b0														
16	15	14	13	to	4	3	2	1														

1

Introduction

2

Specification

3

System Configuration

4

Installation

5

Wiring

6

Introduction of Functions

7

Data Link Processing Time

8

Parameter Setting

9

Data Link Procedure

10

Buffer Memory

6.4.5 Data link stop/restart

This function stops and restarts the data link in the host station.

When the data link is stopped in the master station, the data link is stopped in the entire system.

Refer to Subsection 16.4.4 for the data link stop/restart method using GX Works2.

1. The table below shows link special relays and registers related to data link stop/restart

- Link special relay (SB)

SB No.	BFM No.			Name	Description
	Hex.	Dec.	Bit		
SB0000	5E0H	1504	b0	Data link restart	Restarts the data link which was stopped by SB0002. OFF: Does not give restart specification. ON : Gives restart specification.
SB0002	5E0H	1504	b2	Data link stop	Stops the data link in the master station. If the master station sets this relay to ON, the entire system stops. OFF: Does not give stop specification. ON : Gives stop specification.
SB0040	5E4H	1508	b0	Data link restart acceptance status	Indicates the data link restart specification acceptance status. OFF: Not accepted ON : Accepted
SB0041	5E4H	1508	b1	Data link restart completion status	Indicates the data link restart specification acceptance completion status. OFF: Not completed ON : Completed
SB0044	5E4H	1508	b4	Data link stop acceptance	Indicates the data link stop specification acceptance status. OFF: Not accepted ON : Accepted
SB0045	5E4H	1508	b5	Data link stop complete	Indicates the data link stop specification acceptance completion status. OFF: Not completed ON : Completed

- Link special register (SW)

SB No.	BFM No.		Name	Description
	Hex.	Dec.		
SW0041	641H	1601	Result of data link restart	Stores the execution result of data link restart specification by SB0000. 0: Normal Other than 0: Stores the error code (Refer to Section 16.3).
SW0045	645H	1605	Result of data link stop	Stores the execution result of data link stop specification by SB0002. 0: Normal Other than 0: Stores the error code (Refer to Section 16.3).

2. The figure below shows a program example to stop/restart the data link

- 1) Relationship between the PLC and the master station

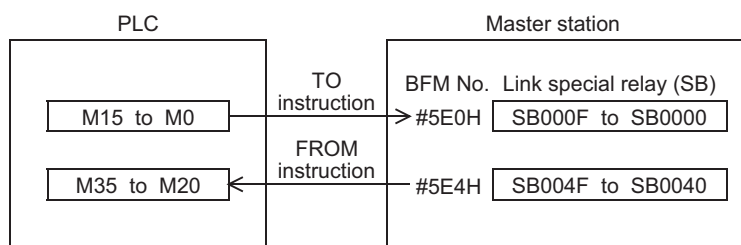

2) Program example

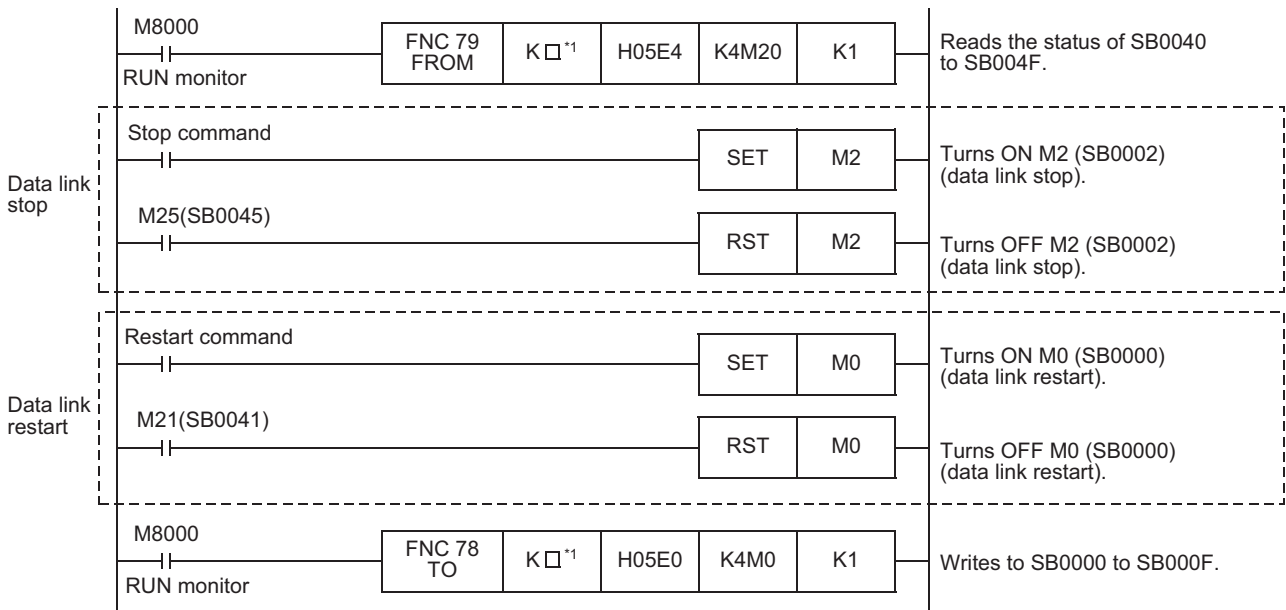

*1. □: Unit No. of FX3U-16CCL-M enters.

Caution

When you have stopped the data link using SB0002, make sure to start up the data link using SB0000.

6.4.6 Station number overlap check function

This function checks the status of actually connected stations when the write request for data link start is given (when BFM#10 b6 is set to ON), and checks whether the assigned station numbers overlap.

1. Number of occupied station number overlap checking

Checks whether or not occupied station numbers duplicate.

(Example)

Intelligent device station (station No. 1 occupies 4 stations)

Station No. 1	Station No. 2	Station No. 3	Station No. 4
---------------	---------------	---------------	---------------



Remote device station (station No. 4 occupies 2 stations)

Station No. 4	Station No. 5
---------------	---------------

- 1) When there is an overlap, the ERR. LED flashes and the overlap status is stored in SW0098 (station number overlap status).
- 2) Even if an overlap exists, data link can be continued with other normally functioning stations.
- 3) When the switch setting is corrected to normal status and the write request for data link startup is given again (BFM#10 b6 is set to ON), the ERR. LED turns off and the data stored in SW0098 (station number overlap status) is cleared.

However, if the starting head number overlaps, it is not regarded as an overlap check target.

(Example)

Intelligent device station (station No. 1 occupies 4 stations)

Station No. 1	Station No. 2	Station No. 3	Station No. 4	Station No. 5	Station No. 6
---------------	---------------	---------------	---------------	---------------	---------------



Remote device station (station No. 1 occupies 2 stations)

Station No. 1	Station No. 2
---------------	---------------

1 Introduction
2 Specification
3 System Configuration
4 Installation
5 Wiring
6 Introduction of Functions
7 Data Link Processing Time
8 Parameter Setting
9 Data Link Procedure
10 Buffer Memory

6.4.7 Increasing the number of cyclic points

This function increases the number of cyclic points.

When increasing the number of cyclic points, select one of the following two modes.

- Remote net ver. 2 mode
Mode suitable for configuring a new system
- Remote net additional mode
Mode suitable for adding a ver. 2 compatible slave station to the existing ver. 1 system

Caution

In the remote net ver. 1 mode, the number of cyclic points cannot be increased.

The expanded cyclic points are extendable within the range shown in the following table.

However, determine the range based on the maximum number of connectable stations with the whole system.

Maximum number of connectable stations

- 1) Remote I/O stations: 8 maximum^{*1}
(Each station occupies 32 I/O points of the PLC.)
 - *1. Up to 4 stations can be connected to the FX3G/FX3GC PLC.
- 2) Remote device stations + Intelligent device stations ≤ 8 maximum
(The total number of RX/RV points is 256 or less.)

Cyclic points

		Expanded cyclic setting			
		Single	Double	Quadruple	Octuple
Occupies 1 station	Remote I/O (RX, RY)	32 points	32 points	64 points	128 points
	Remote register (RWw, RWr)	4 points	8 points	16 points	32 points
Occupies 2 stations	Remote I/O (RX, RY)	64 points	96 points	192 points	Not used
	Remote register (RWw, RWr)	8 points	16 points	32 points	
Occupies 3 stations	Remote I/O (RX, RY)	96 points	160 points	Not used	Not used
	Remote register (RWw, RWr)	12 points	24 points		
Occupies 4 stations	Remote I/O (RX, RY)	128 points	224 points	Not used	Not used
	Remote register (RWw, RWr)	16 points	32 points		

1. Remote net ver. 2 mode

This mode is designed to configure a new system.

The number of cyclic points can be increased as indicated below. For a single station, RX/RV can be increased to up to 128 points and RWw/RWv to up to 32 points.

- The expanded example of a remote output (RY)

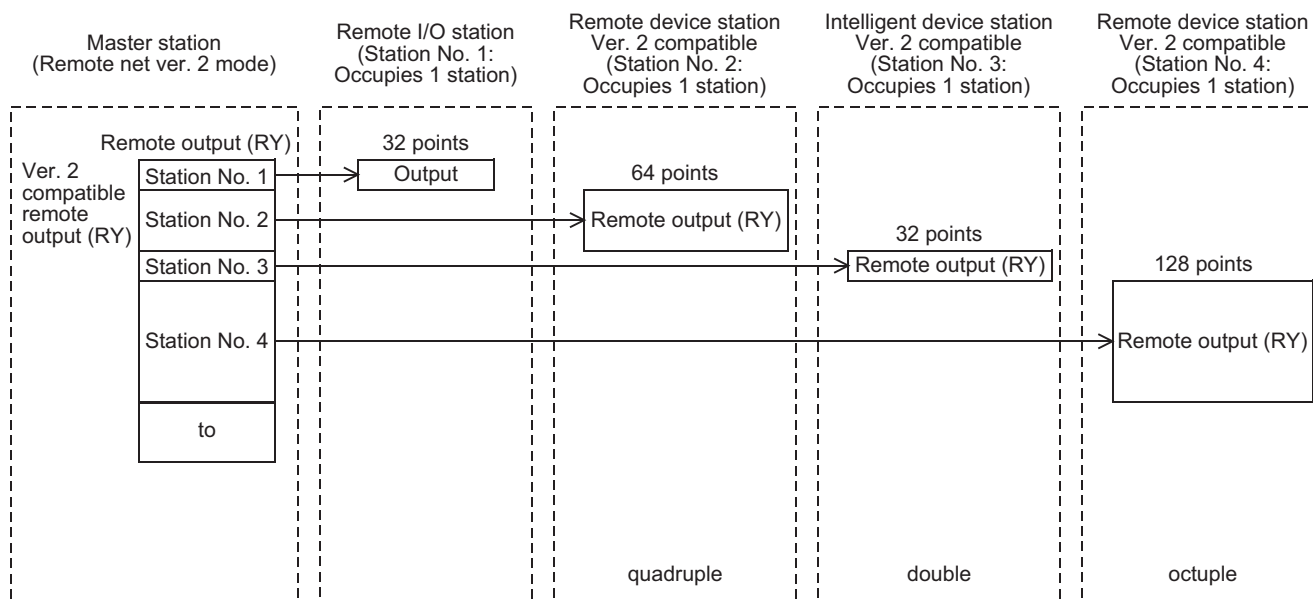

Caution

In remote net ver. 2 mode, the remote registers of the remote I/O stations are set to 0 points.

2. Remote net additional mode

This mode is designed for use when slave stations including a ver. 2 compatible station are added to the existing ver. 1 system.

- The expanded example of a remote output (RY)

In the following example, ver. 2 compatible slave stations are added from station No. 4 and on since the existing system uses stations up to station No. 3.

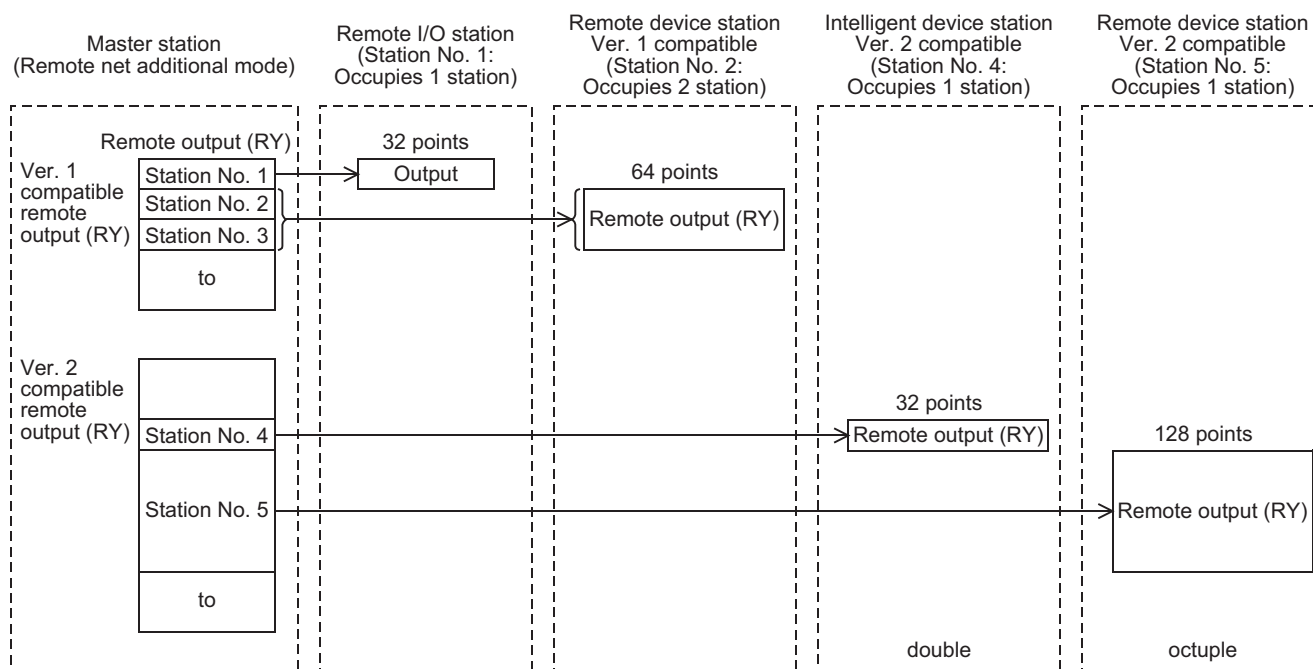

Caution

When you use remote net additional mode, place ver. 1 compatible slave stations before ver. 2 compatible slave stations.

1

Introduction

2

Specification

3

System Configuration

4

Installation

5

Wiring

6

Introduction of Functions

7

Data Link Processing Time

8

Parameter Setting

9

Data Link Procedure

10

Buffer Memory

3. Precautions for cyclic points increase setting

1) Whether system can be configured or not

The following table indicates whether cyclic transmission is possible or not for each station.

		Intelligent device station		Remote device station		Remote I/O station
		Ver. 2 compatible	Ver. 1 compatible	Ver. 2 compatible	Ver. 1 compatible	Ver. 1 compatible
Master station	Remote net ver. 2 mode	✓	✓	✓	✓	✓
	Remote net additional mode	✓	✓	✓	✓	✓
	Remote net ver. 1 mode	×	✓	×	✓	✓

✓ : Cyclic transmission enabled

× : Cyclic transmission disabled

Caution

Data link is not available when the version set in the station type of the master station information is different from that of the remote station.

For example, when the station type of the master station information is set as "ver. 1 remote device station" although the actual remote device station is set to "ver. 2 remote device station", data link cannot be performed with the "ERR." LED on the master station flashing and the "L RUN" LED on the remote device station turned OFF.

2) Whether send/receive is enabled or not

The following table indicates whether send/receive of cyclic data is enabled or not.

			Intelligent device station		Remote device station		Remote I/O station
			Ver. 2 compatible	Ver. 1 compatible	Ver. 2 compatible	Ver. 1 compatible	Ver. 1 compatible
Master station	Remote net ver. 2 mode	Ver. 2 compatible area	✓	✓	✓	✓	✓
		Ver. 1 compatible area	-	-	-	-	-
	Remote net additional mode	Ver. 2 compatible area	✓	×	✓	×	×
		Ver. 1 compatible area	×	✓	×	✓	✓
	Remote net ver. 1 mode	Ver. 2 compatible area	-	-	-	-	-
		Ver. 1 compatible area	×	✓	×	✓	✓

✓ : Cyclic transmission enabled

× : Cyclic transmission disabled

- : Prohibited

4. Mismatch in number of points between parameter-set expanded cyclic setting and installation status

If there is a mismatch in the number of points between the parameter-set expanded cyclic setting and installation status, the FX3U-16CCL-M stores the error code into SW0069. Also, it stores the matching status of each station into SW009C.

6.4.8 Accessing the other station from CC-Link

The operator can execute program writing, program reading, program verification and device batch monitoring to the main unit connected to a FX3U-64CCL from CC-Link using GX Works2.

Refer to Section 3.2 for applicable PLCs and GX Works2 versions.

The communication path of CC-Link is illustrated as follows.

Please refer to the GX Works2 Version 1 Operating Manual (Common) for routing details.

- Communication path for the other station access function from CC-Link

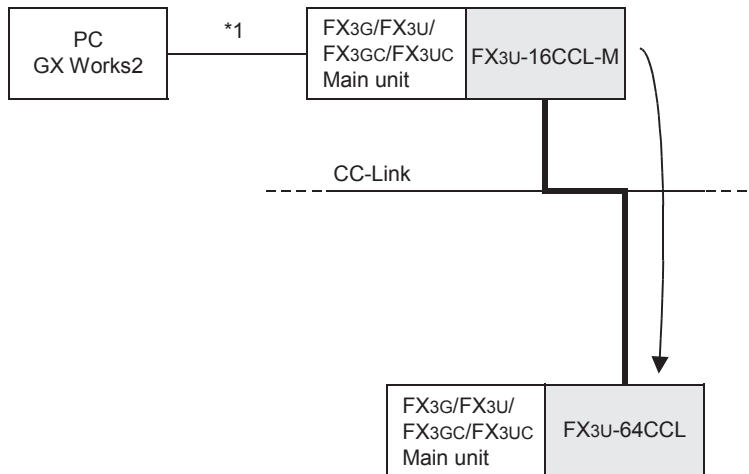

- *1. Direct connection or connection using the GOT transparent mode.

1	Introduction
2	Specification
3	System Configuration
4	Installation
5	Wiring
6	Introduction of Functions
7	Data Link Processing Time
8	Parameter Setting
9	Data Link Procedure
10	Buffer Memory

7. Data Link Processing Time

This chapter explains the data link processing time such as the link scan time and transmission delay time.

7.1 Link Scan Time

This section explains the CC-Link scan time.

When data links are normally being performed among all stations in the CC-Link system, the retry processing time (RT) and the return processing time (F) in the formula are not necessary to be added.

1. Link scan time (LS)

Calculation expression

$$LS = BT \{27 + (NI \times 4.8) + (NW \times 9.6) + (N \times 30) + (ni \times 4.8) + (nw \times 9.6) + TR\} + ST + EX + RT + F [\mu s]$$

- BT: Constant (transmission speed)

Transmission speed	156 kbps	625 kbps	2.5 Mbps	5 Mbps	10 Mbps
BT	51.2	12.8	3.2	1.6	0.8

- NI: The final station number in A, B and C
(Includes the number of dedicated stations but excludes the reserved stations, and must be a multiple of 8.)
 - A: Last station number of remote I/O stations
 - B: Last station number of remote device stations (including the number of occupied stations)
 - C: Last station number of intelligent device stations (including the number of occupied stations)
- NW: The final station number in B and C
(Includes the number of dedicated stations but excludes the reserved stations, and must be a multiple of 8.)

Last station Number	1 to 8	9 to 16
NI, NW	8	16

- N: Number of connected stations (excluding reserved stations)
- ni: a + b + c (excluding reserved stations)
 - a: Total number of occupied stations for remote I/O stations
 - b: Total number of occupied stations for remote device stations
 - c: Total number of occupied stations for intelligent device stations
- nw: b + c (excluding reserved stations)
- TR: Transient processing time (only when a transient request is made)
 - When there is a transient request from the master station: 180
 - When there is a transient request from an intelligent device station:
40.8 × number of transient transmission stations
- ST: Constant
(The largest value found in 1) to 3) below. However, 2) is disregarded when B = 0 and 3) is disregarded when C = 0)
 - 1) 800 + (A × 15)
 - 2) 900 + (B × 50)
 - 3) 1200 + (C × 100)
- EX: Constant (only when remote net ver. 2 mode or remote net additional mode is used)
50 + total in the following table

Expanded cyclic setting	Number of occupied stations			
	Occupies 1 station	Occupies 2 stations	Occupies 3 stations	Occupies 4 stations
single	0	0	0	0
double	70 × Number of stations	80 × Number of stations	90 × Number of stations	100 × Number of stations
quadruple	90 × Number of stations	110 × Number of stations	-	-
octuple	110 × Number of stations	-	-	-

- RT: Retry processing time (only applies to the link scan with a faulty slave station in which data link is being performed)
 $\alpha + \beta \times (\text{Number of the detected faulty stations} - 1)$
 - α : Retry processing time of the first station
 $BT \times \{(200 + R) \times \text{Retry count setting value} + 178.5\}$
 - When a transient request is made
 $R: 13.2 + (NI \times 4.8) + (NW \times 9.6) + 180$
 - When a transient request is not made
 $R: 13.2 + (NI \times 4.8) + (NW \times 9.6)$
 - β : Retry processing time of the second and subsequent stations
 $BT \times \{(200 + P) \times \text{Retry count setting value} + 178.5\}$
 $P: 10.8$
- F: Return processing time (only when there is a faulty station)
 $BT \times \{243.1 + 210.8 \times (\text{number of automatic return modules} - 1)\} + ST$

2. Calculation example

Using the following system configuration when the transmission speed is 10 Mbps (assuming that there is no faulty station, transient transmission or retry)

Example of system configuration

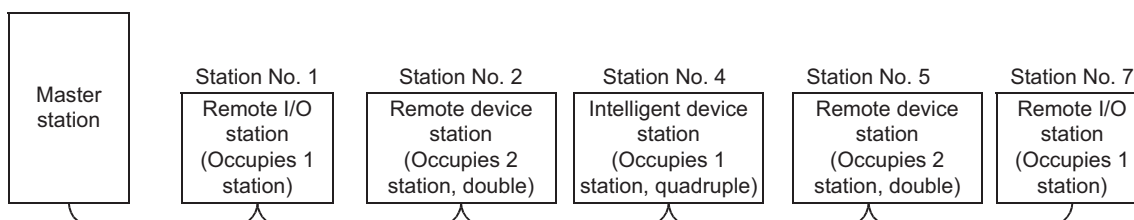

Calculation expression

$$LS = BT \{27 + (NI \times 4.8) + (NW \times 9.6) + (N \times 30) + (Ni \times 4.8) + (nw \times 9.6) + TR\} + ST + EX + RT + F [\mu s]$$

- $BT = 0.8$
- $ST = 1600$
 - 1) $800 + (7 \times 15) = 905$
 - 2) $900 + (6 \times 50) = 1200$
 - 3) $1200 + (4 \times 100) = 1600$
- $EX = 250$
 $\{50 + 80 (\text{occupies 2 stations, double}) \times 2 + 90 (\text{occupies 1 stations, quadruple}) \times 1 = 250\}$
- $NI = 7 \rightarrow 8$
- $NW = 6 \rightarrow 8$
- $N = 5$ (Number of connected units)
- $Ni = 7$ (Total number of stations occupied)
- $nw = 5$ (Number of stations occupied other than the remote I/O station)
- $TR = 0$ (No transient transmission)
- $RT = 0$ (No retry)
- $F = 0$ (No faulty station)

$$\begin{aligned}
 LS &= BT \{27 + (NI \times 4.8) + (NW \times 9.6) + (N \times 30) + (Ni \times 4.8) + (nw \times 9.6) + TR\} + ST + EX + RT + F \\
 &= 0.8 \{27 + (8 \times 4.8) + (8 \times 9.6) + (5 \times 30) + (7 \times 4.8) + (5 \times 9.6) + 0\} + 1600 + 250 + 0 + 0 \\
 &= 2149.0 [\mu s] \\
 &= 2.149 [ms]
 \end{aligned}$$

7.2 Transmission Delay Time

This section explains the transmission delay time (the time until data is transmitted).

When consistency control is being used, it becomes delay time from a consistency control completed.

→ For details on the consistency control, refer to Subsection 6.3.6.

7.2.1 Master station <-> Remote I/O station

1. Master station (RX) <- Remote I/O station (input)

This indicates the time from the moment a signal is input to a remote I/O station until the corresponding master station PLC device turns ON (OFF).

Calculation expression

SM + LS × 2 + Remote I/O station processing time [ms]

- SM: Master station sequence program scan time
- LS: Link scan time

2. Master station (RY) -> Remote I/O station (output)

This indicates the time from the moment a master station PLC device turns ON (OFF) until a remote I/O station output turns ON (OFF).

Calculation expression

SM + LS × 2 + Remote I/O station processing time [ms]

- SM: Master station sequence program scan time
- LS: Link scan time

7.2.2 Master station <-> Remote device station (Ver. 1 compatible slave station)

1. Master station (RX) <- Remote device station (RX)

This indicates the time from the moment a signal is input to a remote device station until the corresponding master station PLC device turns ON (OFF).

Calculation expression

SM + LS × 2 + Remote device station processing time [ms]

- SM: Master station sequence program scan time
- LS: Link scan time

2. Master station (RY) -> Remote device station (RY)

This indicates the time from the moment a master station PLC device turns ON (OFF) until a remote device station output turns ON (OFF).

Calculation expression

SM + LS × 2 + Remote device station processing time [ms]

- SM: Master station sequence program scan time
- LS: Link scan time

3. Master station (RWw) -> Remote device station (RWw)

This indicates the time from when data is set to a master station PLC device until the corresponding data on the remote device station is changed.

Calculation expression

SM + LS × 2 + Remote device station processing time [ms]

- SM: Master station sequence program scan time
- LS: Link scan time

4. Master station (RWr) <- Remote device station (RWr)

This indicates the time from when data is set to a master station PLC device until the corresponding data on the remote device station is changed.

Calculation expression

$$\mathbf{SM + LS \times 2 + Remote\ device\ station\ processing\ time\ [ms]}$$

- SM: Master station sequence program scan time
- LS: Link scan time

7.2.3 Master station <-> Remote device station (Ver. 2 compatible slave station)**1. Master station (RX) <- Remote device station (RX)**

This indicates the time from the moment a signal is input to a remote device station until the corresponding master station PLC device turns ON (OFF).

Calculation expression

$$\mathbf{SM + LS \times 2 \times m + Remote\ device\ station\ processing\ time\ [ms]}$$

- SM: Master station sequence program scan time
- LS: Link scan time
- m: Constant (Constant set in the extended cyclic setting)

Expanded cyclic setting	Single	Double	Quadruple	Octuple
m	1	3	7	15

2. Master station (RY) -> Remote device station (RY)

This indicates the time from the moment a master station PLC device turns ON (OFF) until a remote device station output turns ON (OFF).

Calculation expression

$$\mathbf{SM + LS \times (2 \times m + 1) + Remote\ device\ station\ processing\ time\ [ms]}$$

- SM: Master station sequence program scan time
- LS: Link scan time
- m: Constant (Constant set in the extended cyclic setting)

Expanded cyclic setting	Single	Double	Quadruple	Octuple
m	1	3	7	15

3. Master station (RWw) -> Remote device station (RWw)

This indicates the time from when data is set to a master station PLC device until the corresponding data on the remote device station is changed.

Calculation expression

$$\mathbf{SM + LS \times (2 \times m + 1) + Remote\ device\ station\ processing\ time\ [ms]}$$

- SM: Master station sequence program scan time
- LS: Link scan time
- m: Constant (Constant set in the extended cyclic setting)

Expanded cyclic setting	Single	Double	Quadruple	Octuple
m	1	3	7	15

4. Master station (RWr) <- Remote device station (RWr)

This indicates the time from when data is set to a master station PLC device until the corresponding data on the remote device station is changed.

Calculation expression

$SM + LS \times 2 \times m + \text{Remote device station processing time [ms]}$

- SM: Master station sequence program scan time
- LS: Link scan time
- m: Constant (Constant set in the extended cyclic setting)

Expanded cyclic setting	Single	Double	Quadruple	Octuple
m	1	3	7	15

7.2.4 Master station <-> Intelligent device station (Ver. 1 compatible slave station)**1. Master station (RX) <- Intelligent device station (RX)**

This indicates the time from the moment a signal is input to an intelligent device station until the corresponding master station PLC device turns ON (OFF).

Calculation expression

$SM + LS \times 3 + \text{Intelligent device station processing time [ms]}$

- SM: Master station sequence program scan time
- LS: Link scan time

2. Master station (RY) -> Intelligent device station (RY)

This indicates the time from the moment a master station PLC device turns ON (OFF) until an intelligent device station output turns ON (OFF).

Calculation expression

$SM + LS \times 3 + \text{Intelligent device station processing time [ms]}$

- SM: Master station sequence program scan time
- LS: Link scan time

3. Master station (RWw) -> Intelligent device station (RWw)

This indicates the time from when data is set to a master station PLC device until the corresponding data on the intelligent device station is changed.

Calculation expression

$SM + LS \times 3 + \text{Intelligent device station processing time [ms]}$

- SM: Master station sequence program scan time
- LS: Link scan time

4. Master station (RWr) <- Intelligent device station (RWr)

This indicates the time from when data is set to a master station PLC device until the corresponding data on the intelligent device station is changed.

Calculation expression

$SM + LS \times 3 + \text{Intelligent device station processing time [ms]}$

- SM: Master station sequence program scan time
- LS: Link scan time

7.2.5 Master station <-> Intelligent device station (Ver. 2 compatible slave station)

1. Master station (RX) <- Intelligent device station (RX)

This indicates the time from the moment a signal is input to an intelligent device station until the corresponding master station PLC device turns ON (OFF).

Calculation expression

SM + LS × (2 × m + 1) + Intelligent device station processing time [ms]

- SM: Master station sequence program scan time
- LS: Link scan time
- m: Constant (Constant set in the extended cyclic setting)

Expanded cyclic setting	Single	Double	Quadruple	Octuple
m	1	3	7	15

2. Master station (RY) -> Intelligent device station (RY)

This indicates the time from the moment a master station PLC device turns ON (OFF) until an intelligent device station output turns ON (OFF).

Calculation expression

SM + LS × (2 × m + 1) + Intelligent device station processing time [ms]

- SM: Master station sequence program scan time
- LS: Link scan time
- m: Constant (Constant set in the extended cyclic setting)

Expanded cyclic setting	Single	Double	Quadruple	Octuple
m	1	3	7	15

3. Master station (RWw) -> Intelligent device station (RWw)

This indicates the time from when data is set to a master station PLC device until the corresponding data on the intelligent device station is changed.

Calculation expression

SM + LS × (2 × m + 1) + Intelligent device station processing time [ms]

- SM: Master station sequence program scan time
- LS: Link scan time
- m: Constant (Constant set in the extended cyclic setting)

Expanded cyclic setting	Single	Double	Quadruple	Octuple
m	1	3	7	15

4. Master station (RWr) <- Intelligent device station (RWr)

This indicates the time from when data is set to a master station PLC device until the corresponding data on the intelligent device station is changed.

Calculation expression

SM + LS × (2 × m + 1) + Intelligent device station processing time [ms]

- SM: Master station sequence program scan time
- LS: Link scan time
- m: Constant (Constant set in the extended cyclic setting)

Expanded cyclic setting	Single	Double	Quadruple	Octuple
m	1	3	7	15

1

Introduction

2

Specification

3

System Configuration

4

Installation

5

Wiring

6

Introduction of Functions

7

Data Link Processing Time

8

Parameter Setting

9

Data Link Procedure

10

Buffer Memory

7.3 Status of Each Station when an Error has Occurred

7.3.1 Status of master station and remote I/O station when an error has occurred

The table below shows the status of master station and remote I/O station when an error has occurred.

Data link status			Master station				Remote I/O station	
			Remote input (RX)	Remote output (RY)	Remote register (RWw)	Remote register (RWr)	Input	Output
When the master station PLC is stopped (data link continues)			Continue	Clear	Continue	Continue	Continue	Clear
When data link is stopped in the entire system	Data link disorder station setting (master station setting)	Clear	Clear	Undefined	Undefined	Keep	By external signals	All OFF
		Keep	Keep					
When a communication error occurred (due to power OFF, etc.) in a remote I/O station	Data link disorder station setting (master station setting)	Clear	Clears the receive area for data from remote I/O station with a communication error.	Continue	Continue	Continue	By external signals	All OFF
		Keep	Keeps the receive area for data from remote I/O station with a communication error.					
When a communication error occurred (due to power OFF, etc.) in a remote device station	Data link disorder station setting (master station setting)	Clear	Clears the receive area for data from remote device station with a communication error.	Continue	Continue	Keeps the receive area for data from remote device station with a communication error.	Continue (Not affected by the communication status of the remote device station)	Continue (Not affected by the communication status of the remote device station)
		Keep	Keeps the receive area for data from remote device station with a communication error.					
When a communication error occurred (due to power OFF, etc.) in an intelligent device station	Data link disorder station setting (master station setting)	Clear	Clears the receive area for data from intelligent device station with a communication error.	Continue	Continue	Keeps the receive area for data from intelligent device station with a communication error.	Continue (Not affected by the communication status of the intelligent device station)	Continue (Not affected by the communication status of the intelligent device station)
		Keep	Keeps the receive area for data from intelligent device station with a communication error.					

7.3.2 Status of remote device station and intelligent device station when an error has occurred

The table below shows the status of remote device station and intelligent device station when an error has occurred.

Data link status			Remote device station			
			Remote input (RX)	Remote output (RY)	Remote register (RWw)	Remote register (RWr)
When the master station PLC is stopped (data link continues)			Continue	Clear	Continue	Continue
When data link is stopped in the entire system	Data link disorder station setting (master station setting)	Clear	Undefined	All OFF	Undefined	Undefined
		Keep				
When a communication error occurred (due to power OFF, etc.) in a remote I/O station	Data link disorder station setting (master station setting)	Clear	Continue	Continue	Continue	Continue
		Keep				
When a communication error occurred (due to power OFF, etc.) in a remote device station	Data link disorder station setting (master station setting)	Clear	Undefined	Undefined	Undefined	Undefined
		Keep				
When a communication error occurred (due to power OFF, etc.) in an intelligent device station	Data link disorder station setting (master station setting)	Clear	Continue	Continue	Continue	Continue
		Keep				

Data link status			Intelligent device station			
			Remote input (RX)	Remote output (RY)	Remote register (RWw)	Remote register (RWr)
When the master station PLC is stopped (data link continues)			Continue	Clear	Continue	Continue
When data link is stopped in the entire system	Data link disorder station setting (master station setting)	Clear	Undefined	All OFF	Undefined	Undefined
		Keep				
When a communication error occurred (due to power OFF, etc.) in a remote I/O station	Data link disorder station setting (master station setting)	Clear	Continue	Continue	Continue	Continue
		Keep				
When a communication error occurred (due to power OFF, etc.) in a remote device station	Data link disorder station setting (master station setting)	Clear	Continue	Continue	Continue	Continue
		Keep				
When a communication error occurred (due to power OFF, etc.) in an intelligent device station	Data link disorder station setting (master station setting)	Clear	Undefined	Undefined	Undefined	Undefined
		Keep				

1

Introduction

2

Specification

3

System Configuration

4

Installation

5

Wiring

6

Introduction of Functions

7

Data Link Processing Time

8

Parameter Setting

9

Data Link Procedure

10

Buffer Memory

8. Parameter Setting

This chapter describes the parameter settings required in order to execute data link in the CC-Link system.

8.1 Procedure from Parameter Setting to Data Link Startup

This section describes the flow from parameter setting to data link startup.

When starting up data link from parameter setting, two methods are available, one method using buffer memories and another method using network parameters.

When starting up data link using buffer memories, refer to Subsections 8.1.1 and 8.1.2.

When starting up data link using network parameters, refer to Subsections 8.1.3 and 8.1.4.

Refer to Section 3.2 for applicable PLCs and GX Works2 versions supporting network parameters.

Caution

Do not execute the data link startup method using buffer memories and data link startup method using network parameters at the same time.

8.1.1 Relationship between buffer memory and internal memory

This subsection describes the relationship between the buffer memory and the internal memory in the master station.

1) Buffer memory

This is a temporary storage area to write parameter information to the internal memory.

Write the parameter information to the buffer memory using a sequence program.

When the power of the master block is turned off, parameter information is erased.

2) Internal memory

Data link is executed using the parameter information stored in the internal memory.

When the power of the master block is turned off, parameter information is erased.

8.1.2 Procedure from parameter settings to data link startup with buffer memory

Follow the procedure below from parameter settings to data link startup. Refer to Section 8.3 for parameter setting using a sequence program.

Procedure 1

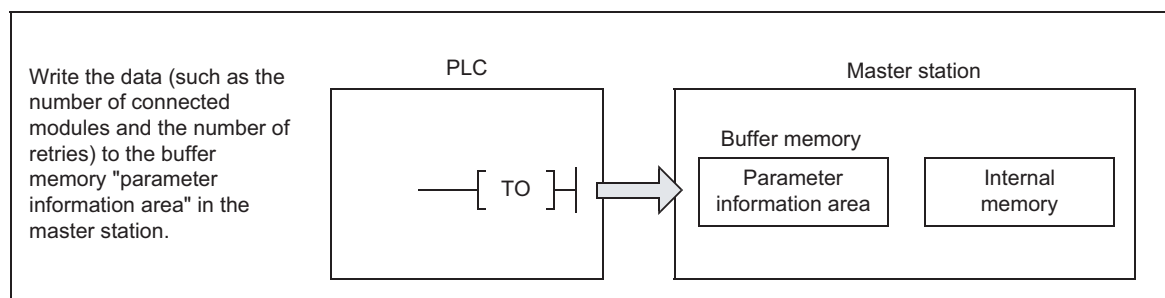

Procedure 2

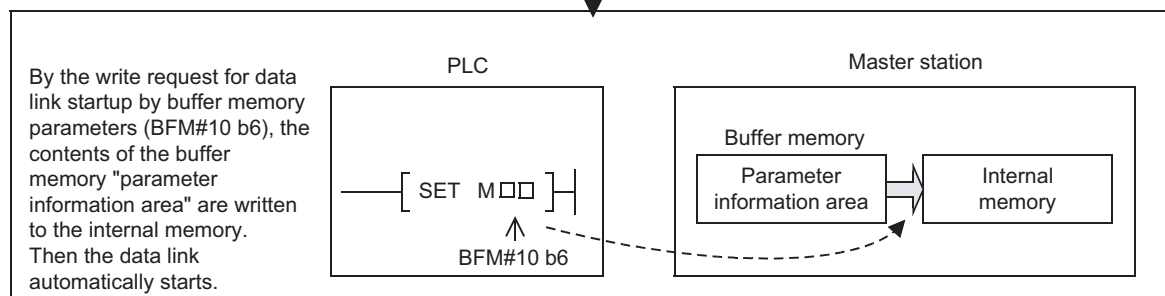

8.1.3 Relationship between network parameter and internal memory

This subsection describes the relationship between the network parameter and the internal memory.

- 1) Network parameter
Write network parameters to the parameter area of the PLC using GX Works2.
When the power of the PLC is turned ON, network parameters are stored in the internal memory of the master station.
- 2) Internal memory
Network parameters stored in the internal memory execute data link.
The internal memory information is reflected also on the parameter information area in buffer memories.
When the power of the master block is turned OFF, the parameter information is erased.

8.1.4 Procedure from parameter settings to data link startup with GX Works2

Follow the procedure below from parameter settings to data link startup. Refer to Section 8.4 for parameter setting using GX Works2.

Procedure 1

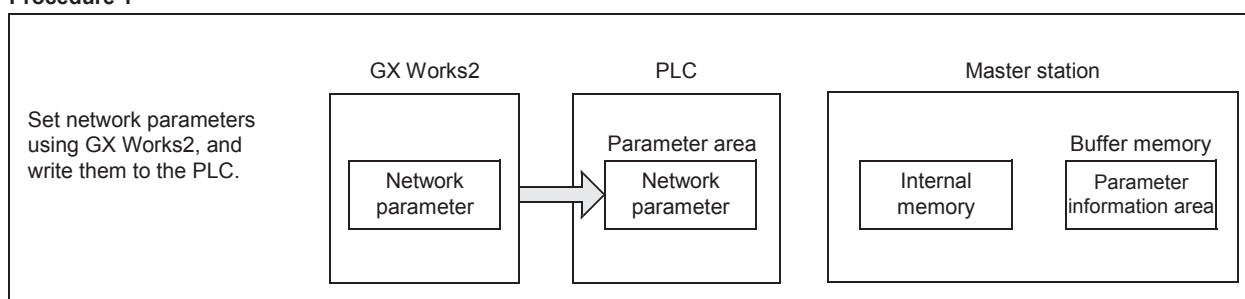

Procedure 2

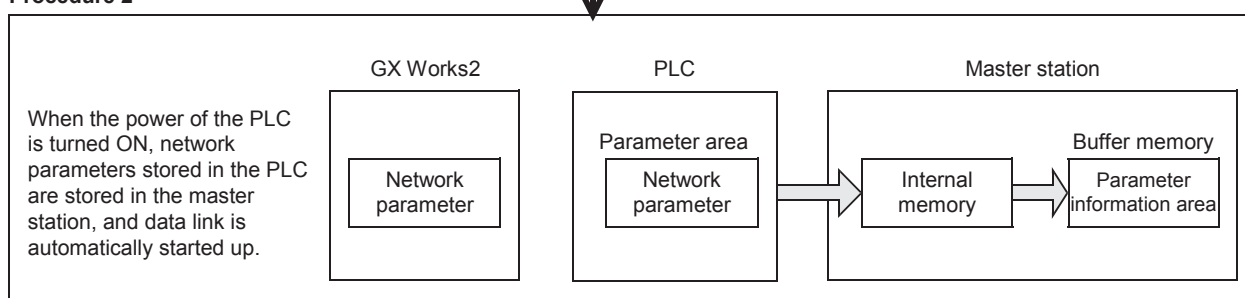

8.2 Parameter Setting Items

The table below shows the items set in the buffer memory "parameter information area" in the master station.

BFM No.		Item	Description	Initial value	Reference						
Hex.	Dec.										
#0H	#0	Mode	Sets the operation mode of the master station. [Setting range] 0: Remote net ver. 1 mode 1: Remote net additional mode 2: Remote net ver. 2 mode	K0	Subsection 10.3.1						
#1H	#1	Number of connected units	Sets the number of remote station and intelligent device station (including reserved stations) connected to the master station. [Setting range] For FX3U/FX3UC PLC 1 to 16 (units) For FX3G/FX3GC PLC 1 to 12 (units)	K8	Subsection 10.3.2						
#2H	#2	Number of retries	Sets the number of retries executed when communication error occurs. [Setting range] 1 to 7 (times)	K3	Subsection 10.3.3						
#3H	#3	Number of automatic return units	Sets the number of remote station and intelligent device station which can recover in one link scan. [Setting range] 1 to 10 (units)	K1	Subsection 10.3.4						
#6H	#6	Operation specification when CPU is down	Specifies the data link status when an error occurs in the master station PLC CPU. [Setting range] 0: Stop 1: Continue	K0	Subsection 10.3.5						
#0CH	#12	Data link disorder station setting	Specifies the input status for the data link error station. [Setting range] 0: Hold 1: Clear	K1	Subsection 10.3.6						
#0DH	#13	Case of CPU STOP setting	Specifies the slave station refresh/compulsory clear setting at programmable controller CPU STOP. [Setting range] 0: Refresh 1: Clears compulsorily	K0	Subsection 10.3.7						
#10H	#16	Reserved station specification	Specifies reserved stations. [Setting range] 0 to FFFE _H (Set to ON the bits corresponding to the station numbers to be set as reserved.)	K0	Subsection 10.3.8						
#14H	#20	Error invalid station specification	Specifies invalid stations. [Setting range] 0 to FFFF _H (Set to ON the bits corresponding to the station numbers to be set as error invalid stations.)	K0	Subsection 10.3.9						
#20H to #2FH	#32 to #47	Station information	Sets the type of connected remote station and intelligent device station (including reserved stations). [Setting range] As shown below <table border="1" style="margin-left: 20px;"> <tr> <td style="text-align: center;">b15 to b12</td> <td style="text-align: center;">b11 to b8</td> <td style="text-align: center;">b7 to b0</td> </tr> <tr> <td style="text-align: center;">Station type</td> <td style="text-align: center;">Number of occupied stations</td> <td style="text-align: center;">Station No.</td> </tr> </table> <p style="margin-left: 20px;"> 1: Occupies 1 station 2: Occupies 2 stations 3: Occupies 3 stations 4: Occupies 4 stations 1 to 16 (01H to 10H) </p> <p style="margin-left: 20px;"> 0H: Ver. 1 compatible remote I/O station 1H: Ver. 1 compatible remote device station 2H: Ver. 1 compatible intelligent device station 5H: Ver. 2 compatible single remote device station 6H: Ver. 2 compatible single intelligent device station 8H: Ver. 2 compatible double remote device station 9H: Ver. 2 compatible double intelligent device station BH: Ver. 2 compatible quadruple remote device station CH: Ver. 2 compatible quadruple intelligent device station EH: Ver. 2 compatible octuple remote device station FH: Ver. 2 compatible octuple intelligent device station </p>	b15 to b12	b11 to b8	b7 to b0	Station type	Number of occupied stations	Station No.	*1	Subsection 10.3.10
b15 to b12	b11 to b8	b7 to b0									
Station type	Number of occupied stations	Station No.									

BFM#32 to #39: 0101H to 0108H, BFM#40 to #47: 0000H

8.3 Parameter Setting from Sequence Program

This section explains the parameter setting within the sequence program.

Caution

The auxiliary relays in the non-keep area must be used as auxiliary relays (M) for parameter setting programs. For details, refer to Section 11.1.

Parameter setting program

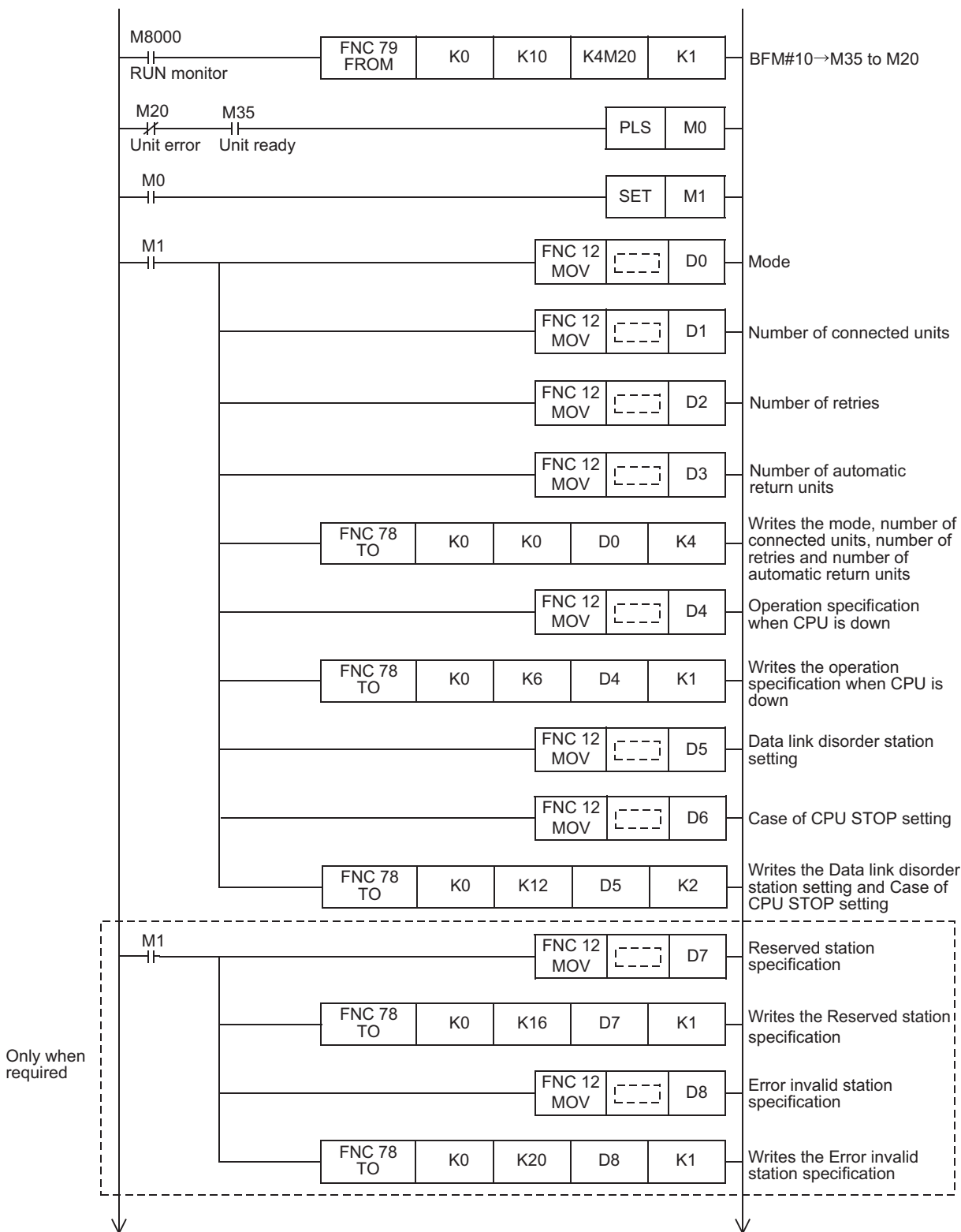

- 1 Introduction
- 2 Specification
- 3 System Configuration
- 4 Installation
- 5 Wiring
- 6 Introduction of Functions
- 7 Data Link Processing Time
- 8 Parameter Setting
- 9 Data Link Procedure
- 10 Buffer Memory

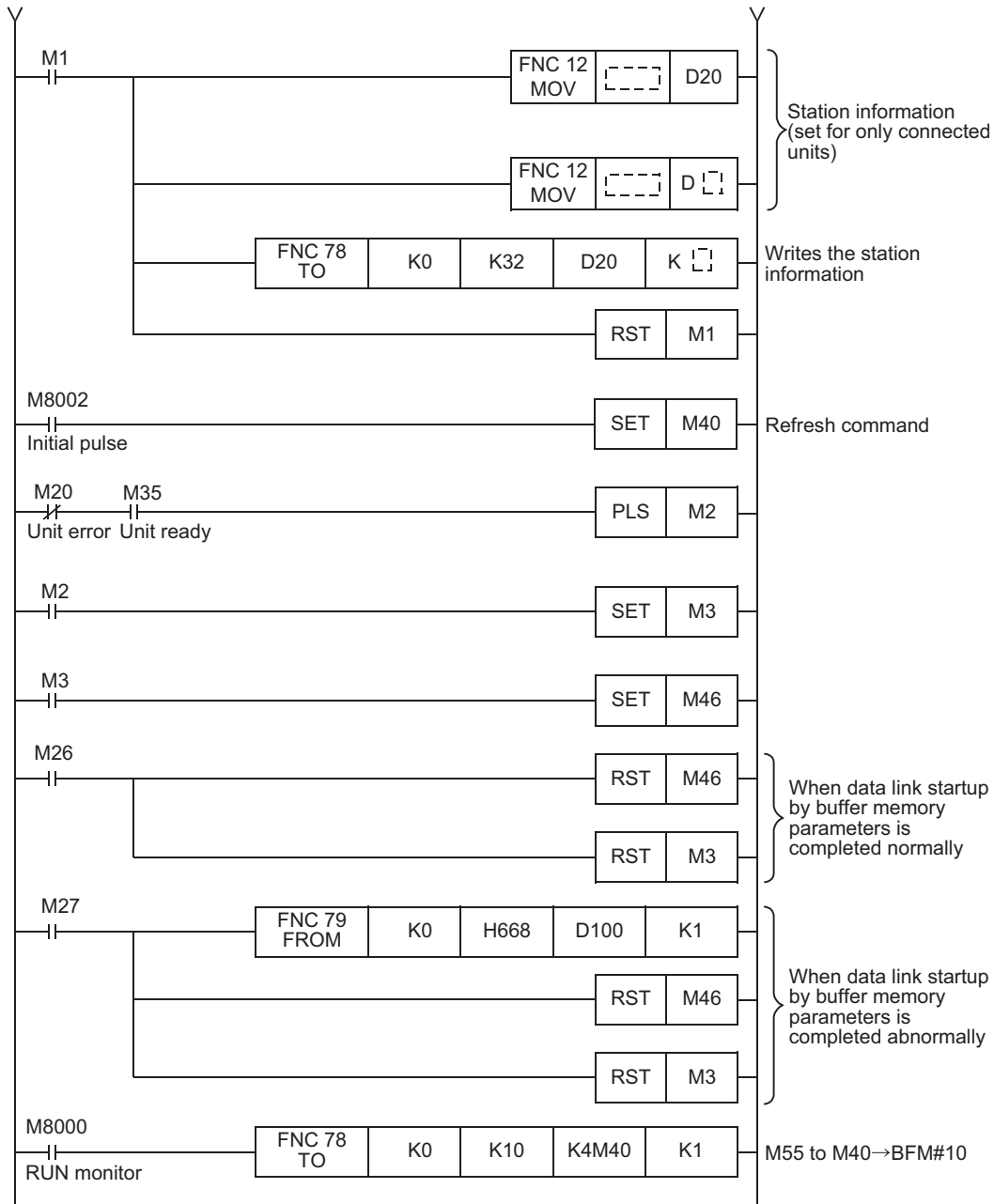

8.4 Parameter Setting from GX Works2

This section describes parameter setting using GX Works2.

Refer to the GX Works2 Version 1 Operating Manual (Common) for details of GX Works2 operation procedures.

8.4.1 Network parameter setting

Set network parameters on the "Network Parameter" screen.

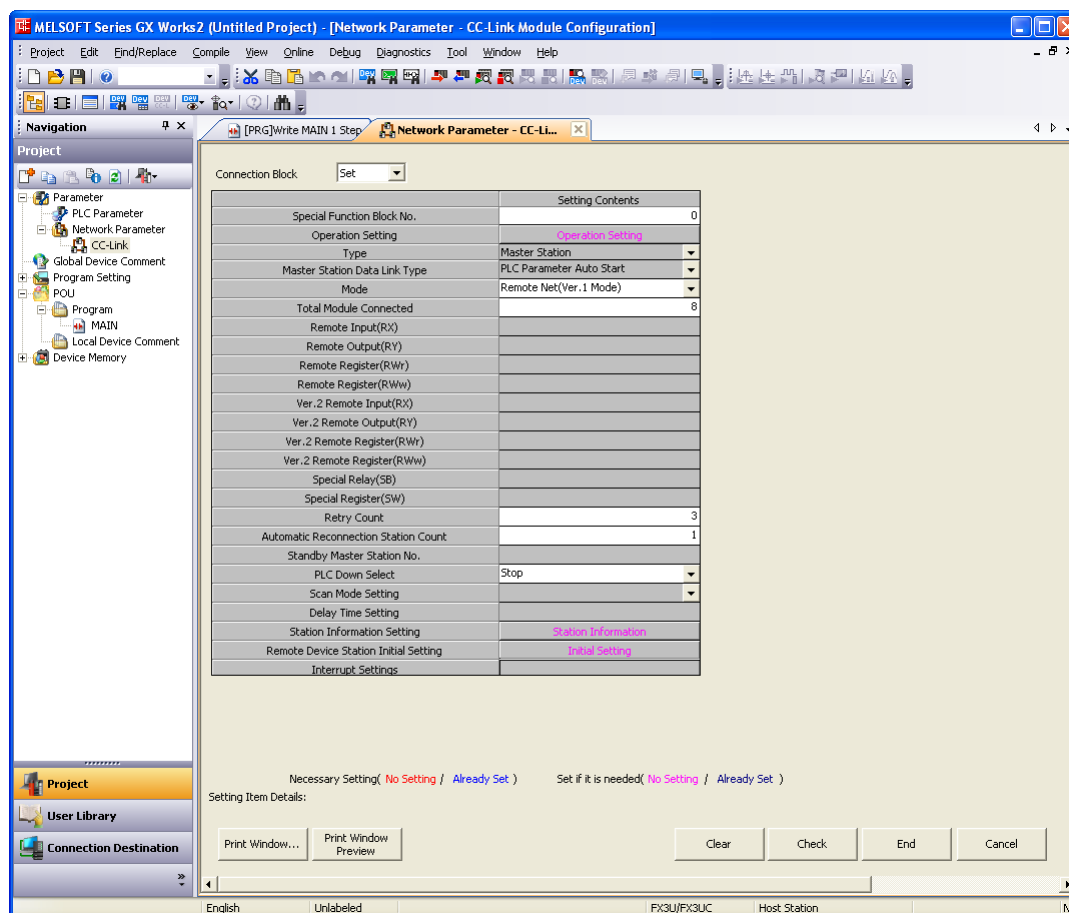

Set item	Description
Connection Block	Select whether or not the FX3U-16CCL-M is connected. Not Set Set
Special Function Block No.	Set the special function block number of the FX3U-16CCL-M. [Setting range] 0 to 7
Operation setting	Click the [Operation Setting] button to display the "Operation Setting" screen. (Refer to Subsection 8.4.2)
Type	Fixed to "Master Station" when "Connection Block" is set to "Set".
Master Station Data Link Type	Fixed to "PLC Parameter Auto Start" when "Connection Block" is set to "Set".
Mode	Select the operation mode of the master station. Remote Net(Ver.1 Mode) Remote Net(Ver.2 Mode) Remote Net(Additional Mode)
Total Module Connected	Set the number of remote stations and intelligent device stations (including reserved stations) connected to the master station. [Setting range] For FX3U/FX3UC PLC 1 to 16 For FX3G/FX3GC PLC 1 to 12

1

Introduction

2

Specification

3

System Configuration

4

Installation

5

Wiring

6

Introduction of Functions

7

Data Link Processing Time

8

Parameter Setting

9

Data Link Procedure

10

Buffer Memory

Set item	Description
Retry Count	Set the number of retries to be executed when a communication error occurs. [Setting range] 1 to 7
Automatic Reconnection Station Count	Set the number of remote stations and intelligent device stations which can be automatically reconnected by 1-link scan. [Setting range] 1 to 10
PLC Down Select	Select the data link status to become effective when an error occurs in the master station PLC. Stop Continue
Station Information Setting	Displays the "CC-Link Station Information" screen when clicked. (Refer to Subsection 8.4.3)
Remote Device Station Initial Setting	Displays the "Remote Device Station Initial Setting Target Station No. Setting" screen when clicked. (Refer to Subsection 6.4.1)

8.4.2 Operation setting

On the "Operation Setting" screen, set "Parameter Name", "Data Link Disorder Station Setting" and "Case of CPU STOP Setting".

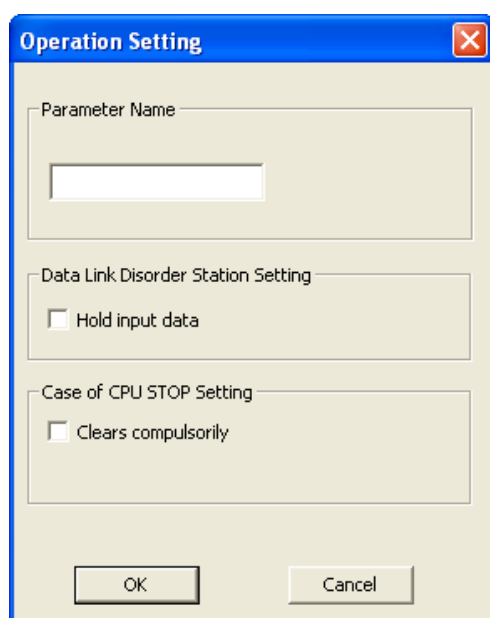

Set item	Description
Parameter Name	Set the parameter name. (Even if the parameter name is not set, this will not affect the operation of the CC-Link system). [Setting range] 8 half-width characters
Data Link Disorder Station Setting	Set the input status for the data link error station. "Hold input data" not checked: Clear "Hold input data" checked : Hold
Case of CPU STOP Setting	Set the slave station refresh/compulsory clear setting at programmable controller CPU STOP. "Clears compulsorily" not checked: Refresh "Clears compulsorily" checked : Clears compulsorily

8.4.3 Station Information Setting

On the "CC-Link Station Information" screen, set the station information.

Station No.	Station Type	Expanded Cyclic Setting	Number of Occupied Stations	Remote Station Points	Reserve/Invalid Station Select
1/ 1	Remote I/O Station	Single	Occupied Station 1	32Points	No Setting
2/ 2	Remote I/O Station	Single	Occupied Station 1	32Points	No Setting
3/ 3	Remote I/O Station	Single	Occupied Station 1	32Points	No Setting
4/ 4	Remote I/O Station	Single	Occupied Station 1	32Points	No Setting
5/ 5	Remote I/O Station	Single	Occupied Station 1	32Points	No Setting
6/ 6	Remote I/O Station	Single	Occupied Station 1	32Points	No Setting
7/ 7	Remote I/O Station	Single	Occupied Station 1	32Points	No Setting
8/ 8	Remote I/O Station	Single	Occupied Station 1	32Points	No Setting

Set item	Description
Station No.	Displays "Number of connected stations/Start station number" (including the number of exclusively occupied stations).
Station Type	Select the slave station type. When the mode is set to "Remote Net(Ver.1 Mode)" No Setting Remote I/O Station Remote Device Station Intelligent Device Station When the mode is set to "Remote Net(Ver. 2 Mode)" or "Remote Net(Additional Mode)" No Setting Ver.1 Remote I/O Station Ver.1 Remote Device Station Ver.1 Intelligent Device Station Ver.2 Remote Device Station Ver.2 Intelligent Device Station
Expanded Cyclic Setting	When the station type is Ver. 2 compatible slave station, select the expanded cyclic setting. Single Double Quadruple Octuple
Number of Occupied Stations	Select the number of stations exclusively occupied by the slave station. No Setting Occupied Station 1 Occupied Stations 2 Occupied Stations 3 Occupied Stations 4
Remote Station Points	Displays the number of remote station points of the slave station in according to "Station Type", "Occupied Count" and "Expanded Cyclic Setting". Refer to Section 2.3 for the number of points.
Reserve/Invalid Station Select	Select whether the slave station is a reserved one or error invalid one. No Setting Reserved Station Invalid Station

Caution

Local stations can not be connected.

1

Introduction

2

Specification

3

System Configuration

4

Installation

5

Wiring

6

Introduction of Functions

7

Data Link Processing Time

8

Parameter Setting

9

Data Link Procedure

10

Buffer Memory

8.5 Example of Parameter Setting

This section shows the parameter setting in the system configuration example shown below. Refer to Subsection 8.5.2 for the parameter setting method using a sequence program. Refer to Subsection 8.5.3 for the parameter setting method using network parameters.

8.5.1 Example of system configuration

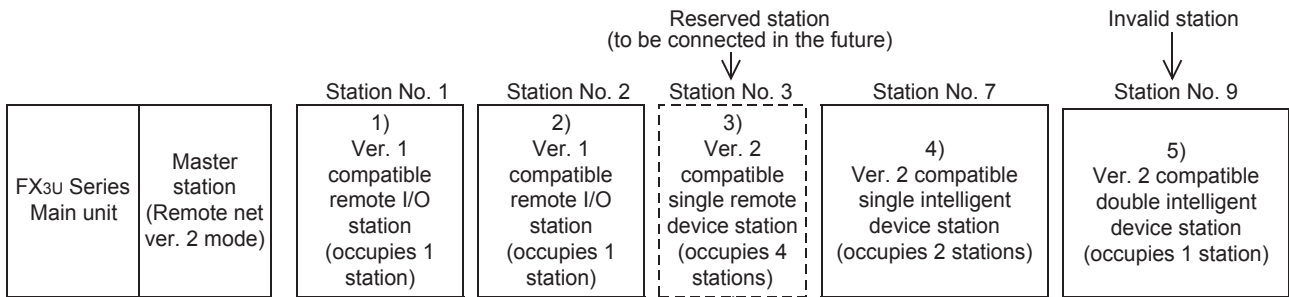

Caution

Local station can not be connected.

8.5.2 Example of program for parameter setting

This example shows the parameter setting using a sequence program.

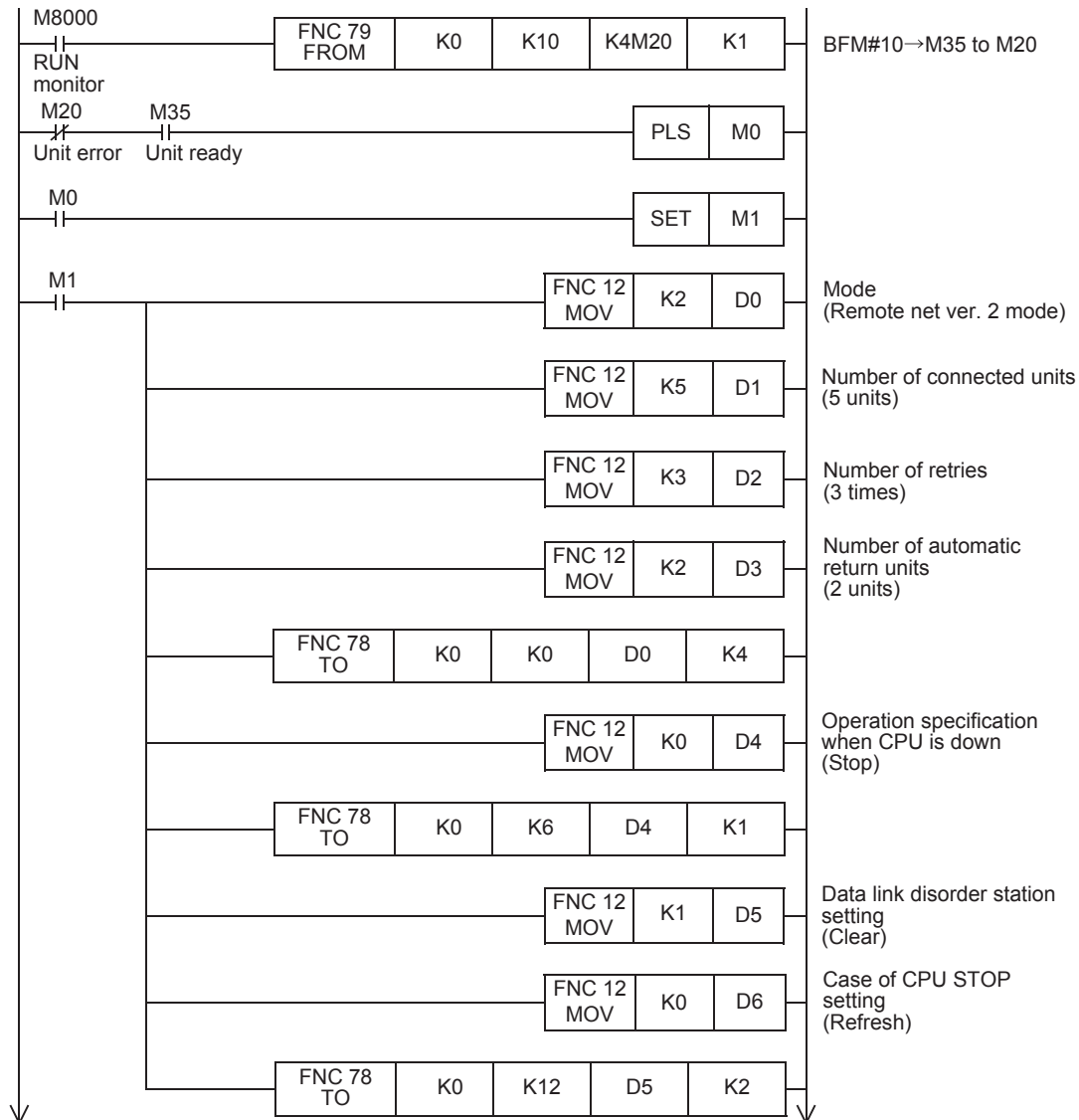

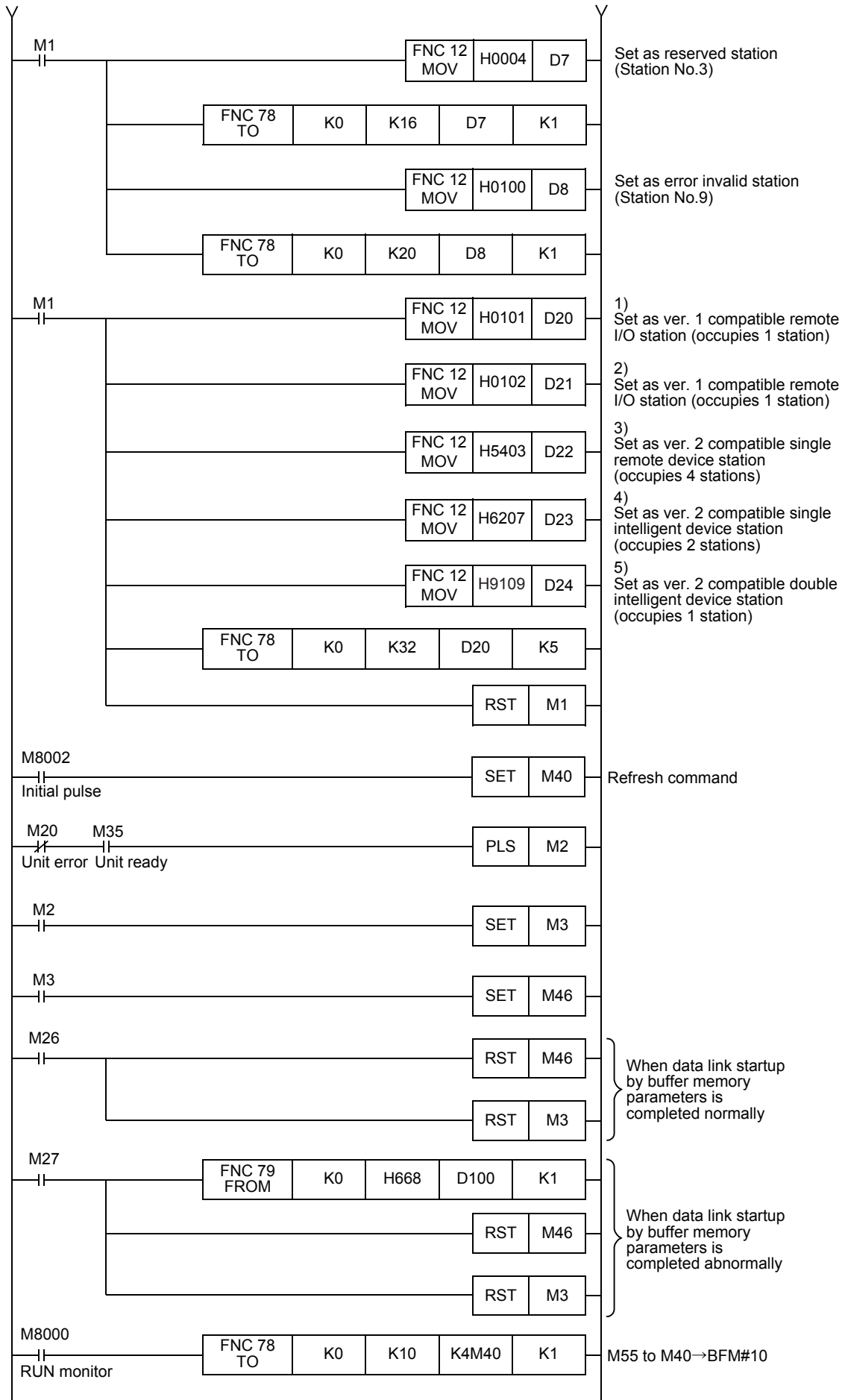

1	Introduction
2	Specification
3	System Configuration
4	Installation
5	Wiring
6	Introduction of Functions
7	Data Link Processing Time
8	Parameter Setting
9	Data Link Procedure
10	Buffer Memory

8.5.3 Parameter setting using network parameters

This subsection describes the parameter setting using GX Works2.

1. Network parameter

Set network parameters as shown below.

Setting Contents	Setting Contents
Special Function Block No.	0
Operation Setting	Operation Setting
Type	Master Station
Master Station Data Link Type	PLC Parameter Auto Start
Mode	Remote Net(Ver.2 Mode)
Total Module Connected	5
Remote Input(RX)	
Remote Output(RY)	
Remote Register(RWr)	
Remote Register(RWw)	
Ver.2 Remote Input(RX)	
Ver.2 Remote Output(RY)	
Ver.2 Remote Register(RWr)	
Ver.2 Remote Register(RWw)	
Special Relay(SB)	
Special Register(SW)	
Retry Count	3
Automatic Reconnection Station Count	2
Standby Master Station No.	
PLC Down Select	Stop
Scan Mode Setting	
Delay Time Setting	
Station Information Setting	Station Information
Remote Device Station Initial Setting	Initial Setting
Interrupt Settings	

Necessary Setting(No Setting / Already Set) Set if it is needed(No Setting / Already Set)

Setting Item Details:

Print Window... Print Window Preview Clear Check End Cancel

Set item	Description
Connection Block	Set "Set".
Special Function Block No.	Set "0".
Mode	Set "Remote Net(Ver.2 Mode)".
Total Module Connected	Set "5".
Retry Count	Set "3".
Automatic Reconnection Station Count	Set "2".
PLC Down Select	Set "Stop".

2. Operation setting

Set the operation setting as shown below.

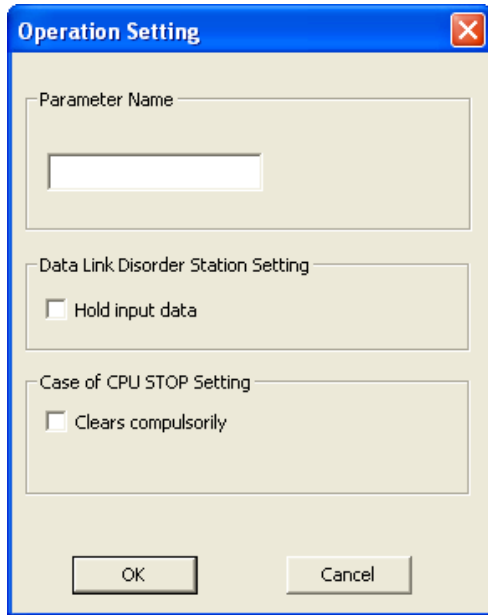

Set item	Description
Parameter Name	Do not set the parameter name. (Even if the Parameter name is not set, this will not affect the operation of the CC-Link system).
Data Link Disorder Station Setting	Uncheck the item "Hold input data".
Case of CPU STOP Setting	Uncheck the item "Clears compulsorily".

3. Station information setting

Set the station information as shown below.

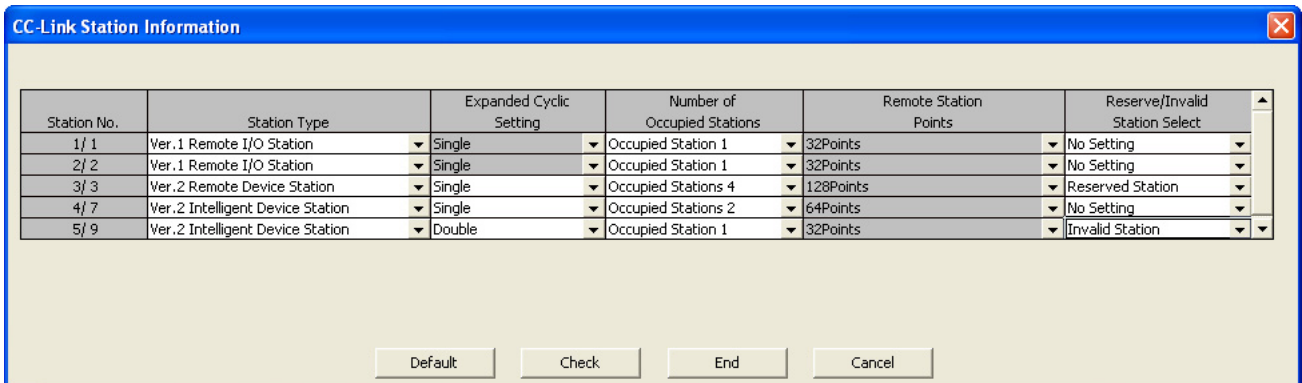

Station No.	Station Type	Expanded Cyclic Setting	Number of Occupied Stations	Remote Station Points	Reserve/Invalid Station Select
1/1	Ver.1 Remote I/O Station	Single	Occupied Station 1	32Points	No Setting
2/2	Ver.1 Remote I/O Station	Single	Occupied Station 1	32Points	No Setting
3/3	Ver.2 Remote Device Station	Single	Occupied Stations 4	128Points	Reserved Station
4/7	Ver.2 Intelligent Device Station	Single	Occupied Stations 2	64Points	No Setting
5/9	Ver.2 Intelligent Device Station	Double	Occupied Station 1	32Points	Invalid Station

Caution

Local stations can not be connected.

1 Introduction

2 Specification

3 System Configuration

4 Installation

5 Wiring

6 Introduction of Functions

7 Data Link Processing Time

8 Parameter Setting

9 Data Link Procedure

10 Buffer Memory

9. Data Link Procedure

DESIGN PRECAUTIONS



DANGER

- When executing control (data changes) to an operating PLC, construct an interlock circuit in the sequence program so that the entire system operates conservatively.
In addition, when executing control such as program changes and operation status changes (status control) to an operating PLC, thoroughly read the manual and sufficiently confirm safety in advance.
Especially in control from external equipment to a PLC in a remote place, problems in the PLC may not be able to be handled promptly due to abnormality in data transfer.
Construct an interlock circuit in the sequence program. At the same time, determine the actions in the system between the external equipment and the PLC for protection against abnormalities in data transfer.
- Make sure to include the following safety circuits outside the PLC to ensure safe system operation even during external power supply problems or PLC failure.
Otherwise, malfunctions may cause serious accidents.
 - 1) Above all, the following components should be included: an emergency stop circuit, a protection circuit, an interlock circuit for opposite movements (such as normal vs. reverse rotation), and an interlock circuit (to prevent damage to the equipment at the upper and lower positioning limits).
 - 2) Note that when the PLC main unit detects an error during self diagnosis, such as a watchdog timer error, all outputs are turned off. Also, when an error that cannot be detected by the PLC main unit occurs in an input/ output control block, output control may be disabled.
External circuits and mechanisms should be designed to ensure safe machinery operation in such cases.

DESIGN PRECAUTIONS

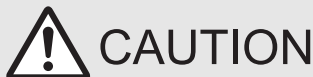

CAUTION

- Observe the following items. Failure to do so may cause incorrect data-writing through noise to the PLC and result in PLC failure, machine damage or other accident.
 - 1) Do not bundle the control line together with or lay it close to the main circuit or power line. As a guideline, lay the control line at least 100mm (3.94") or more away from the main circuit or power line.
Noise may cause malfunctions.
 - 2) Ground the shield wire or shield of a shielded cable. Do not use common grounding with heavy electrical systems
- Do not apply excessive pressure to the power supply terminal block or CC-Link connection terminal block.
Excessive pressure may cause damage or error.

STARTUP AND MAINTENANCE PRECAUTIONS



DANGER

- Do not touch any terminal while the PLC's power is on.
Doing so may cause electric shock or malfunctions.
- Before cleaning or retightening terminals, cut off all phases of the power supply externally.
Failure to do so may cause electric shock.
- Before modifying or disrupting the program in operation or running the PLC, carefully read through this manual and the associated manuals and ensure the safety of the operation.
An operation error may damage the machinery or cause accidents.

STARTUP AND MAINTENANCE PRECAUTIONS



CAUTION

- Do not disassemble or modify the PLC.
Doing so may cause fire, equipment failures, or malfunctions.
For repair, contact your local Mitsubishi Electric representative.
- Turn off the power to the PLC before connecting or disconnecting any extension cable.
Failure to do so may cause equipment failures or malfunctions.
- Turn off the power to the PLC before attaching or detaching the following devices.
- Failure to do so may cause equipment failures or malfunctions.
 - Peripheral devices, display modules, expansion boards and special adapters
 - I/O extension units/blocks, FX Series terminal block and the special function units/blocks
 - Battery and memory cassette

9.1 Data Link Procedure

The flowchart below shows the procedure for data link in the CC-Link system.

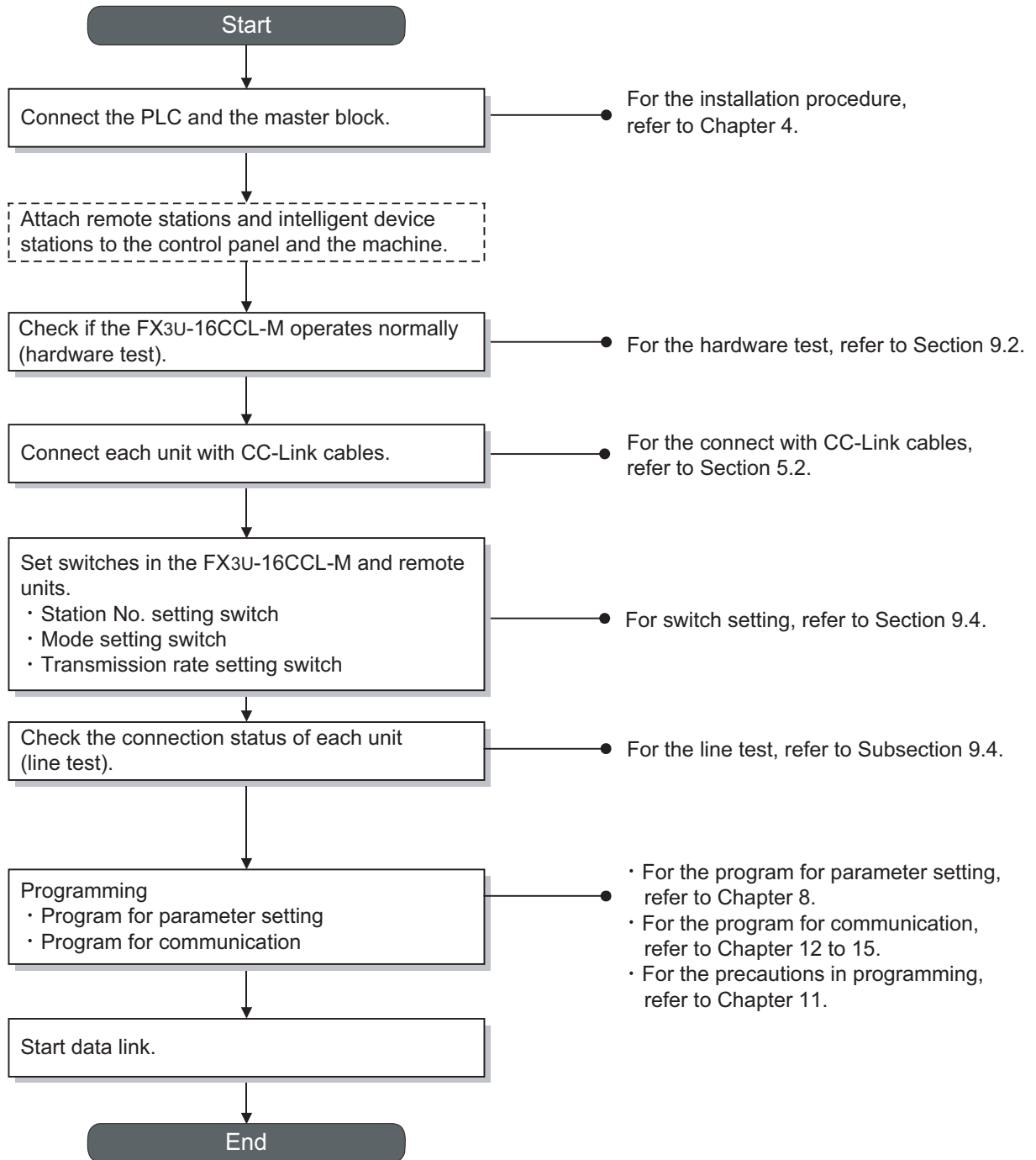

1	Introduction
2	Specification
3	System Configuration
4	Installation
5	Wiring
6	Introduction of Functions
7	Data Link Processing Time
8	Parameter Setting
9	Data Link Procedure
10	Buffer Memory

9.2 Hardware Test (Master Block Status Check)

Using only the FX3U-16CCL-M, confirm that the hardware operates normally. Make sure to execute the hardware test before configuring the CC-Link system. Make sure to execute the hardware test using the FX3U-16CCL-M without any CC-Link cable connections. Connected CC-Link cables disable normal operation of the hardware test. Check the following items in the hardware test.

Hardware test
Communication LSI test (Include for the CC-Link interface circuit)
ROM test
RAM test
Timer functionality test
Watchdog timer functionality test

- The following sequence outlines the hardware test execution procedure:
 - 1) Power OFF the FX3U-16CCL-M.
 - 2) Connect a terminal resistor between the terminals [DA] and [DB] in the FX3U-16CCL-M.
 - 3) A transmission rate setting switch is set as "A" to "E" (hardware test mode).
 - 4) Set the station number setting switches of the FX3U-16CCL-M to "× 10: 0" and "× 1: 0".
 - 5) Power ON the PLC and the FX3U-16CCL-M.
 - 6) Confirm the test results using LEDs of the FX3U-16CCL-M.
 - When the initial communication processing is normally completed: The RUN LED turns ON.
 - Normal status:
The watchdog timer function is activated, and the RUN LED turns OFF.
 - Abnormal status:
The ERR. LED flickers to indicate abnormality in the hardware.

9.3 Switch setting

Set the station number, transmission rate, hardware test, line test and transmission speed test using the rotary switches located under the top cover of the FX3U-16CCL-M.

The setting contents of each switch becomes valid after FX3U-16CCL-M startup. Set the switches while the power to the PLC and FX3U-16CCL-M is OFF. If the switch settings are changed after FX3U-16CCL-M startup, the L ERR. LED will flicker. To make the switch setting changes valid, reset the power of the PLC and the FX3U-16CCL-M.

9.3.1 Station number setting

1. Station number setting of the FX3U-16CCL-M

Set the station number using two station number setting switches (Setting range: 0 to 9).

Setting items	Range	Description
× 10	0, 1	Online: 0 (Master station)
× 1	0 to 9	Line test: 0 to 16

Caution

When a station number setting is 17 to 99, the ERR. LED turns ON.

2. The set the station number of the remote stations and intelligent device stations.

The explanation of method to set the station number of the remote stations and intelligent device stations. Specify the station numbers according to the following conditions.

- 1) Set the station numbers to be consecutive.
The station number can be set without regard to the connection order.
For a unit occupying 2 or more stations, set the head station number.
 - 2) Do not skip station numbers.
Skipped station numbers are treated as "data link faulty stations. However, by setting such stations as a reserved station they are not treated as data link faulty stations.
Data link faulty stations can be checked in the link special register SW0080 (BFM#1664).
- When one station number is skipped

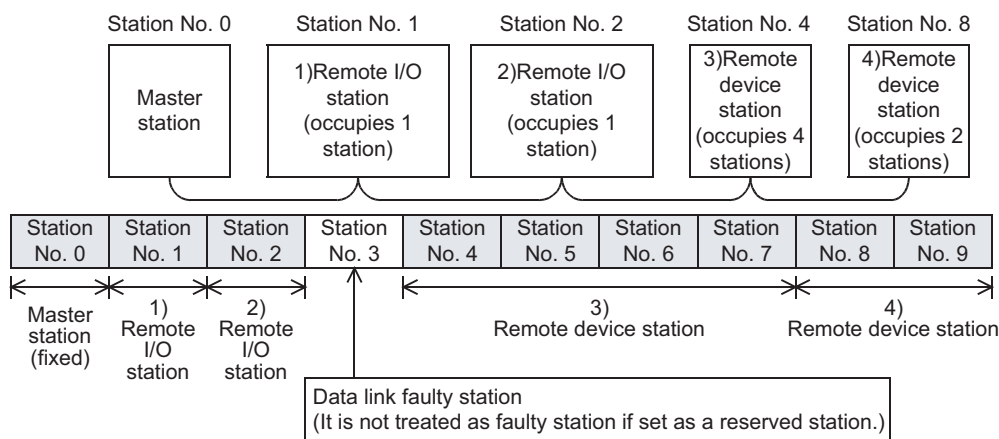

1

Introduction

2

Specification

3

System Configuration

4

Installation

5

Wiring

6

Introduction of Functions

7

Data Link Processing Time

8

Parameter Setting

9

Data Link Procedure

10

Buffer Memory

- 3) Duplicate station numbers are not allowed.
 If there are duplicate numbers, a loading status error occurs.
 The error code is stored in SW0069 (BFM#1641).
 - When one station number is duplicated

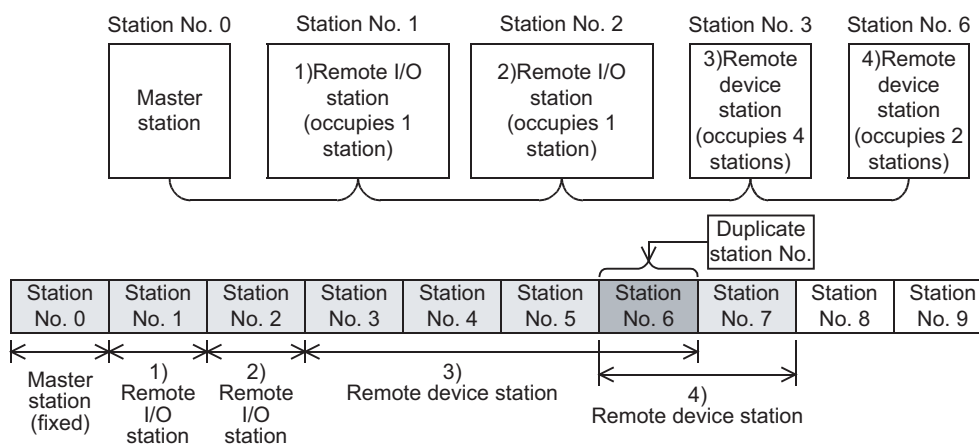

9.3.2 Transmission rate setting, line test, hardware test, transmission speed test

Set the transmission rate setting, line test, hardware test and transmission speed test using the transmission rate setting switch (Setting range: 0 to E).

For details on the transmission rate setting, line test, hardware test, transmission speed test, refer to the following.

→ For details on the line test, refer to Section 9.4.

→ For details on the hardware test, refer to Section 9.2.

→ For details on the transmission speed test, refer to Section 9.5.

Setting	Transmission rate setting	Mode
0	Transmission rate 156 Kbps	<ul style="list-style-type: none"> • Online • Transmission speed test
1	Transmission rate 625 Kbps	
2	Transmission rate 2.5 Mbps	
3	Transmission rate 5 Mbps	
4	Transmission rate 10 Mbps	
5	Transmission rate 156 Kbps	Line test <ul style="list-style-type: none"> • When the station number setting switch is 0: Line test 1 • When the station number setting switch is 1 to 16: Line test 2
6	Transmission rate 625 Kbps	
7	Transmission rate 2.5 Mbps	
8	Transmission rate 5 Mbps	
9	Transmission rate 10 Mbps	Hardware test
A	Transmission rate 156 Kbps	
B	Transmission rate 625 Kbps	
C	Transmission rate 2.5 Mbps	
D	Transmission rate 5 Mbps	Unusable
E	Transmission rate 10 Mbps	
F	Unusable	

Caution

- Set the same transmission speed to the master station and remote stations/intelligent device stations. If the setting is different in even one station, normal data link is not possible.
- The maximum transmission and distance cable length between stations that can be set varies depending on the transmission speed.
 For details, refer to Section 2.5.

9.4 Line Test (Connection Status Check)

After connecting all of the units with CC-Link dedicated cables, verify that they are correctly connected and that data linking can be performed with remote stations and intelligent device stations.

Refer to Subsection 16.4.2 for the line test method using GX Works2.

Check whether data link can be normally executed with all (16) remote stations and intelligent device stations.

Line test 2 checks the status of communication with specific remote stations and intelligent device stations.

Neither line test 1 nor line test 2 requires parameter settings.

Point

Execute line test 2 when an error occurs in line test 1.

Accordingly, when no error is detected in the line test 1, there is no necessity to execute line test 2.

9.4.1 Line test 1

Check whether data link can be normally executed with all (16) remote stations and intelligent device stations. Line test 1 does not requires parameter settings.

• The following sequence outlines the line test 1 execution procedure:

- 1) Set the station number setting switches of the FX3U-16CCL-M to "× 10: 0" and "× 1: 0".
- 2) Set the transmission rate setting switch of the FX3U-16CCL-M to "5" to "9" (line test mode).

Caution

Set the same transmission speed to all of the FX3U-16CCL-M and remote stations/intelligent device stations.

- 3) Turn off the power of the PLC and the FX3U-16CCL-M, then turn it on again. Approximately 4 seconds later, line test 1 starts.
- 4) Confirm the line test results using the LEDs of the FX3U-16CCL-M.

[When the line test is complete]

- The L RUN LED turns ON → Communication with or more stations is normal.
- Line test 1 results are stored in SW00B4 (BFM#6B4H). However, since line test 1 is performed for 16 stations, disregard the bit (s) for any unconnected stations.

[When the test is incomplete (all stations are abnormal)]

- The ERR. LED flickers → All stations are faulty or cable is broken. Line test 1 results (error codes) are stored in SW00B8 (BFM#6B84H).
- ON LED: None → Test cannot start (due to abnormality in hardware or power OFF in all stations).

1

Introduction

2

Specification

3

System Configuration

4

Installation

5

Wiring

6

Introduction of Functions

7

Data Link Processing Time

8

Parameter Setting

9

Data Link Procedure

10

Buffer Memory

9.4.2 Line test 2

Execute the line test 2 to check whether data link is normally executed with a specific remote station or intelligent device station.

Line test 2 does not requires parameter settings.

• The following sequence outlines the line test 2 execution procedure:

- 1) Connect only the unit to be tested to the FX3U-16CCL-M. Or turn on only the power of the unit to be tested.
- 2) Set the station number setting switch in the FX3U-16CCL-M to the station No. (1 to 16) of the unit to be tested.
- 3) Set the transmission rate setting switch of the FX3U-16CCL-M to "5" to "9" (line test mode).

Caution

Set the same transmission speed to the FX3U-16CCL-M and remote stations/intelligent device stations.

- 4) Turn off the power of the PLC and the FX3U-16CCL-M, then turn it on again.
Approximately 4 seconds later, line test 2 starts.
- 5) Confirm the line test results using the LEDs of the FX3U-16CCL-M.

[When the line test is complete]

- The L RUN LED turns ON → Communication with the specified remote station or intelligent device station is normal.

[When the test is incomplete (specified station is abnormal)]

- The ERR. LED flickers → Cable is broken, the corresponding station has an error or test transmission text was corrupted.
Line test 2 results (error codes) are stored in SW00B8 (BFM#6B84H).
- ON LED: None → Test cannot start (due to abnormality in hardware or power OFF in specified station).

9.5 Transmission Speed Test

Whether or not the same transmission speed is set for remote stations or intelligent device stations and the FX3U-16CCL-M can be checked.

Since the station No. of the remote stations or intelligent device station with a different transmission speed setting can be identified, a communication error can be resolved easily.

Refer to Subsection 16.4.2 for the transmission speed test method using GX Works2.

• The following sequence outlines the transmission speed test execution procedure:

- 1) Set the station number setting switches of the FX3U-16CCL-M to "× 10: 0" and "× 1: 0".
- 2) Set the "Transmission rate setting switch" of the FX3U-16CCL-M to "0 to 4 (the transmission speed should be the same as when the system is operating)".
- 3) Set the RUN/STOP switch of PLC to STOP.
- 4) Power ON the PLC and the FX3U-16CCL-M.
- 5) Set SB0002 (Data link stop) to ON to stop data link.
- 6) Set SB000B (Transmission speed test request) to ON to start the transmission speed test. Upon start of the test, SB0185 (Transmission speed test accept status) is set to ON.
- 7) Upon completion of the test, SB0186 (Transmission speed test completion status) is set to ON. The transmission speed test is complete in approximately 10 seconds.
- 8) Using SW0183 (Transmission speed test result), check the transmission speed test result. Check if the same transmission speed is set for the remote stations and intelligent device stations and the FX3U-16CCL-M, with SW0184 (Transmission speed test result for each station).
- 9) After confirming the test results, set SB000B (Transmission speed test request) to OFF.

• Timing chart

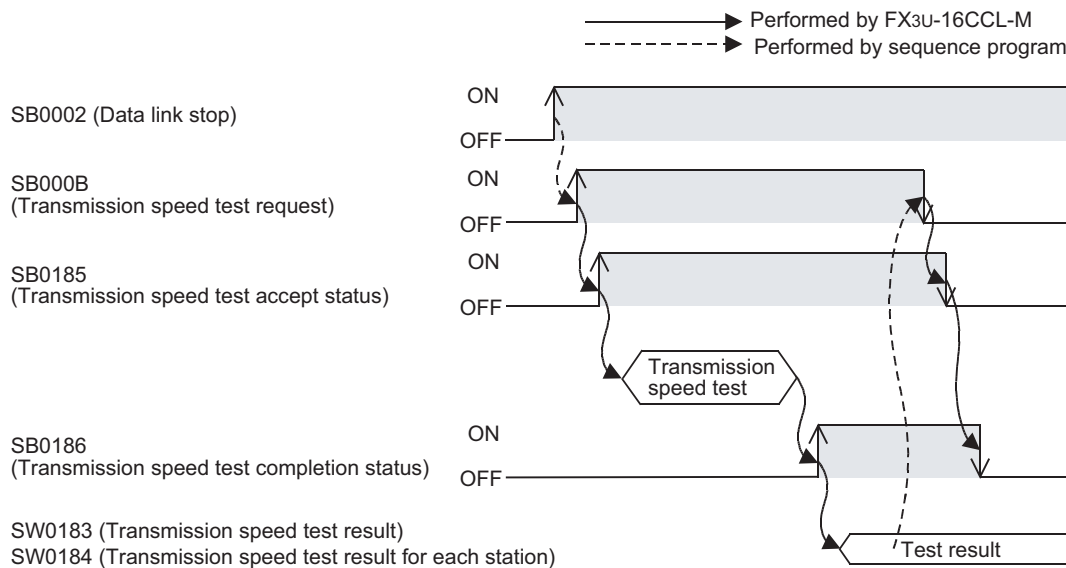

1	Introduction
2	Specification
3	System Configuration
4	Installation
5	Wiring
6	Introduction of Functions
7	Data Link Processing Time
8	Parameter Setting
9	Data Link Procedure
10	Buffer Memory

10. Buffer Memory

10.1 How to read/write from/to buffer memory

To read/write from/to buffer memory in the FX3U-16CCL-M, use the FROM/TO instructions or applied instructions that directly specify the buffer memory. For other methods, refer to the Programming Manual.

10.1.1 FROM/TO instructions

1. FROM instruction (Reading out BFM data to PLC)

Use the FROM instruction to read the data from the buffer memory. If the following program is created, 1 point of data will be read out from the buffer memory BFM #29 of unit No.1 to data register D10.

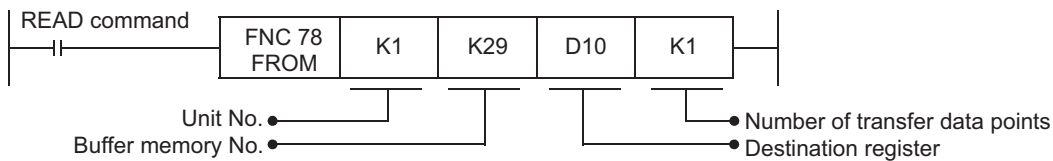

2. TO instruction (Writing PLC data into BFM)

Use the TO instruction to write data to a buffer memory. If the following program is created, 1 point of data (H0001) will be written to buffer memory BFM #0 of unit No.1.

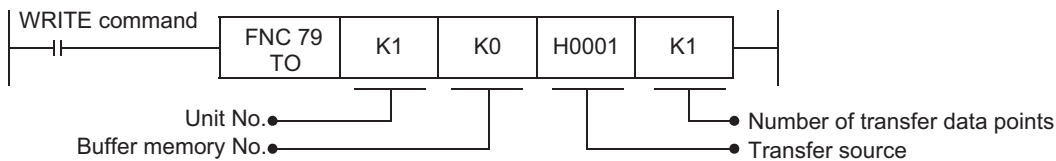

10.1.2 Direct specification of buffer memory

When directly specifying the buffer memory, specify the following device in the source or destination area of the applied instruction as follows:

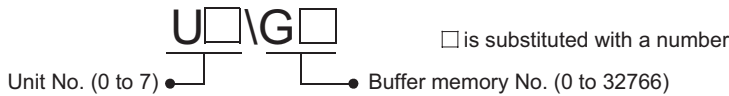

1. Reading out BFM data to PLC (MOV instruction)

If the following program is created, 1 point of data will be read out from the buffer memory BFM #29 of unit No.1 to data register D10.

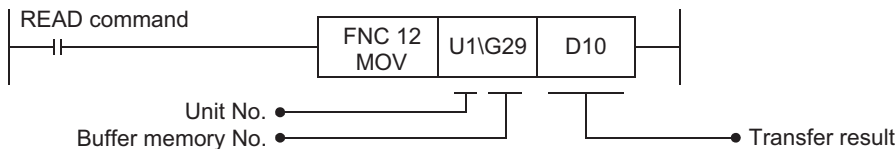

2. Writing PLC data into BFM (MOV instruction)

If the following program is created, 1 point of data (H0001) will be written to buffer memory BFM #0 of unit No.1.

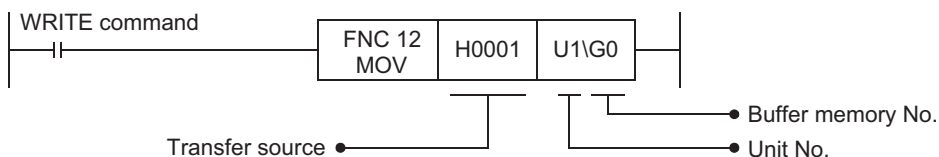

10.2 Buffer Memory List

The table below provides a brief description and reference information for the FX3U-16CCL-M buffer memory.
→ For details on the buffer memory, refer to the Section 10.3 or later.

BFM No.		Item	Description	Read/Write	Reference
Hex.	Dec.				
#0H to #9H	#0 to #9	Parameter information area	Stores the information (parameters) to execute the data link.	R/W ^{*5}	Section 10.3
#AH, #BH	#10, #11	I/O signals to PLC	I/O signals to control the master block	R/W ^{*5}	Section 10.4
#CH to #1BH	#12 to #27	Parameter information area	Stores the information (parameters) to execute the data link.	R/W ^{*5}	Section 10.3
#1CH to #1EH	#28 to #30	Master block control signal	Signals to control the master block	R/W	Section 10.5
#1FH	#31	Use prohibited ^{*1}	-	-	-
#20H to #2FH	#32 to #47	Parameter information area	Stores the information (parameters) to execute the data link.	R/W ^{*5}	Section 10.3
#30H to #DBH	#48 to #219	Use prohibited ^{*1}	-	-	-
#DCH to #DFH	#220 to #223	Consistency control	Consistency control flag (For RX, RY, RWw, RWr flag)	R/W	Section 10.6
#E0H to #FFH	#224 to #255	Remote input (RX) ^{*2}	Stores the input status from a remote station and intelligent device station.	R/O	Section 10.7
#100H to #15FH	#256 to #351	Use prohibited ^{*1}	-	-	-
#160H to #17FH	#352 to #383	Remote output (RY) ^{*2}	Stores the output status to a remote station and intelligent device station.	R/W	Section 10.8
#180H to #1DFH	#384 to #479	Use prohibited ^{*1}	-	-	-
#1E0H to #21FH	#480 to #543	Remote registers (RWw) ^{*2}	Stores the transmission data to a remote station and intelligent device station.	R/W	Section 10.9
#220H to #2DFH	#544 to #735	Use prohibited ^{*1}	-	-	-
#2E0H to #31FH	#736 to #799	Remote registers (RWr) ^{*2}	Stores the received data from a remote station and intelligent device station.	R/O	Section 10.10
#320H to #3DFH	#800 to #991	Use prohibited ^{*1}	-	-	-
#3E0H to #5DFH	#992 to #1503	Slave station offset, size information	Stores the offset and size of RX/RY/RWw/RWr per remote station/intelligent device station.	R/O	Section 10.11
#5E0H to #5FFH	#1504 to #1535	Link special relay (SB)	Stores the data link status.	R/W ^{*4}	Section 10.12
#600H to #7FFH	#1536 to #2047	Link special register (SW)	Stores the data link status.		
#800H to #3FFFH	#2048 to #16383	Use prohibited ^{*1}	-	-	-
#4000H to #401FH	#16384 to #16415	Ver. 2 compatible remote input (RX) ^{*3}	Stores the input status from a remote station and intelligent device station.	R/O	Section 10.13
#4020H to #41FFH	#16416 to #16895	Use prohibited ^{*1}	-	-	-
#4200H to #421FH	#16896 to #16927	Ver. 2 compatible remote output (RY) ^{*3}	Stores the output status to a remote station and intelligent device station.	R/W	Section 10.14
#4220H to #43FFH	#16928 to #17407	Use prohibited ^{*1}	-	-	-
#4400H to #445FH	#17408 to #17503	Ver. 2 compatible remote registers (RWw) ^{*3}	Stores the transmission data to a remote station and intelligent device station.	R/W	Section 10.15
#4460H to #4BFFH	#17504 to #19455	Use prohibited ^{*1}	-	-	-
#4C00H to #4C5FH	#19456 to #19551	Ver. 2 compatible remote registers (RWr) ^{*3}	Stores the received data from a remote station and intelligent device station.	R/O	Section 10.16
#4C60H to	#19552 to	Use prohibited ^{*1}	-	-	-

*1. Do not write to areas that are prohibited to use. Such write may cause errors.

- *2. Used when the remote net ver. 1 mode or remote net additional mode is selected.
- *3. Used when the remote net ver. 2 mode or remote net additional mode is selected.
- *4. Write disabled depending on device. For details, refer to the Section 10.12.
- *5. "R/O" when set using network parameters.

10.3 Parameter information area

Set the conditions to perform the data link.
The table below shows the parameter list.

BFM No.		Item	Description	Read/Write	Initial value
Hex.	Dec.				
#0H	#0	Mode setting	Sets the operation mode of the master station.	R/W ^{*3}	K0
#1H	#1	Number of connected units	Set the number of connected remote stations and intelligent device stations.	R/W ^{*3}	K8
#2H	#2	Number of retries	Set the number of retries to a faulty station.	R/W ^{*3}	K3
#3H	#3	Number of automatic return units	Set the number of remote stations and intelligent device stations that can return to the system during one link scan.	R/W ^{*3}	K1
#4H, #5H	#4, #5	Use prohibited ^{*1}	-	-	-
#6H	#6	Operation specification when CPU is down	Specify the data link status when an error occurs in the master station PLC.	R/W ^{*3}	K0
#7H to #9H	#7 to #9	Use prohibited ^{*1}	-	-	-
#0CH	#12	Data link disorder station setting	Sets the input data status from the data link disorder station.	R/W ^{*3}	K1
#0DH	#13	Case of CPU STOP setting	Sets whether slave stations will be refreshed or compulsorily cleared in case of programmable controller CPU STOP.	R/W ^{*3}	K0
#0EH, #0FH	#14, #15	Use prohibited ^{*1}	-	-	-
#10H	#16	Reserved station specification	Set reserved stations.	R/W ^{*3}	K0
#11H to #13H	#17 to #19	Use prohibited ^{*1}	-	-	-
#14H	#20	Error invalid station specification	Specify error invalid stations.	R/W ^{*3}	K0
#15H to #1BH	#21 to #27	Use prohibited ^{*1}	-	-	-
#20H to #2FH	#32 to #47	Station information	Set the connected station type.	R/W ^{*3}	*2

- *1. Do not write to areas that are prohibited to use. Such write may cause errors.
- *2. BFM#32 to #39: 0101H to 0108H, BFM#40 to #47: 0000H
- *3. "R/O" when set using network parameters.

10.3.1 [BFM#0] Mode setting

Sets the operation mode of the master station.

Setting value	Mode	Explanation	R/W	Initial value
K0	Remote net ver. 1 mode	Mode in which compatibility with the predecessor product (FX2N-16CCL-M) is possible. Select this mode when the number of cyclic points do not used be increased or when the FX3U-16CCL-M is used to replace an existing product module for maintenance.	R/W*1	K0
K1	Remote net additional mode	Select this mode when increasing the number of cyclic points and configuring a new system.		
K2	Remote net ver. 2 mode	Select this mode when adding a ver. 2 compatible slave station to the existing system to increase the number of cyclic points. CC-Link ver. 1 compatible slave stations (not ver. 2 compatible slave station) are also supported by the FX3U-16CCL-M.		

*1. "R/O" when set using network parameters.

Use buffer memory area in each mode of operation

• Remote net ver. 1 mode

Ver.1 area (FX2N-16CCL-M Compatible area)
Ver.1 Remote input (RX) area (BFM#E0H to #FFH)
Ver.1 Remote output (RY) area (BFM#160H to #17FH)
Ver.1 Remote register (RWw) area (BFM#1E0H to #21FH)
Ver.1 Remote register (RWr) area (BFM#2E0H to #31FH)
Ver.2 Expanded area
Remote net ver. 1 mode cannot be used this area.

• Remote net additional mode

Ver.1 area (FX2N-16CCL-M Compatible area)
Ver.1 Remote input (RX) area (BFM#E0H to #FFH)
Ver.1 Remote output (RY) area (BFM#160H to #17FH)
Ver.1 Remote register (RWw) area (BFM#1E0H to #21FH)
Ver.1 Remote register (RWr) area (BFM#2E0H to #31FH)
Ver.2 Expanded area
Ver.2 Remote input (RX) area (BFM#4000H to #401FH)
Ver.2 Remote output (RY) area (BFM#4200H to #421FH)
Ver.2 Remote register (RWw) area (BFM#4400H to #445FH)
Ver.2 Remote register (RWr) area (BFM#4C00H to #4C5FH)

Remote net additional mode uses both of ver. 1 compatible area and ver. 2 expanded area.

• Remote net ver. 2 mode

Ver.1 area (FX2N-16CCL-M Compatible area)
Remote net ver. 2 mode cannot be used this area.
Ver.2 Expanded area
Ver.2 Remote input (RX) area (BFM#4000H to #401FH)
Ver.2 Remote output (RY) area (BFM#4200H to #421FH)
Ver.2 Remote register (RWw) area (BFM#4400H to #443FH)
Ver.2 Remote register (RWr) area (BFM#4C00H to #4C3FH)

Caution

- When you use remote net additional mode, place ver. 1 compatible slave stations before ver. 2 compatible slave stations.
- When values other than 0 to 2 are set, operation is performed in "Remote net ver. 1 mode".

1	Introduction
2	Specification
3	System Configuration
4	Installation
5	Wiring
6	Introduction of Functions
7	Data Link Processing Time
8	Parameter Setting
9	Data Link Procedure
10	Buffer Memory

10.3.2 [BFM#1] Number of connected units

Set the number of connected remote stations and intelligent device stations.

BFM No.		Description	R/W	Default
Hex.	Dec.			
#1H	#1	Setting range: For FX3U/FX3UC PLC 1 to 16 (units) For FX3G/FX3GC PLC 1 to 12 (units)	R/W*1	K8

*1. "R/O" when set using network parameters.

Caution

- Including reserved stations.
- This is not a station count.

10.3.3 [BFM#2] Number of retries

Set the number of retries to a remote station and intelligent device station with a link data error. If a remote stations and intelligent device stations cannot recover the normal data link after executing the specified number of retries, the station is regarded as a "data link faulty station".

BFM No.		Description	R/W	Default
Hex.	Dec.			
#2H	#2	Setting range: 1 to 7 (times)	R/W*1	K3

*1. "R/O" when set using network parameters.

10.3.4 [BFM#3] Number of automatic return units

Set the number of remote stations and intelligent device stations that can return to the system during one link scan.

→ For details on the number of automatic return units, refer to Subsection 6.3.2.

BFM No.		Description	R/W	Default
Hex.	Dec.			
#3H	#3	Setting range: 1 to 10 (units)	R/W*1	K1

*1. "R/O" when set using network parameters.

10.3.5 [BFM#6] Operation specification when CPU is down

Specify the data link status when an "operation stop error" occurs in the master station PLC.

→ For details on the operation specification when CPU is down, refer to Subsection 6.3.3

BFM No.		Description	R/W	Default
Hex.	Dec.			
#6H	#6	0: Stop 1: Continue	R/W*1	K0

*1. "R/O" when set using network parameters.

Caution

Even if an operation continue error occurs in the master station PLC, the data link continues.

10.3.6 [BFM#12] Data link disorder station setting

Sets the input data status from the data link disorder station.

→ For details on the data link disorder station setting, refer to Subsection 6.3.4.

BFM No.		Description	R/W	Default
Hex.	Dec.			
#0CH	#12	0: Hold 1: Clear	R/W*1	K1

*1. "R/O" when set using network parameters.

Caution

When values other than 0 or 1 are set, "Clear" operation is performed.

10.3.7 [BFM#13] Case of CPU STOP setting

Sets whether slave stations will be refreshed or compulsorily cleared in case of programmable controller CPU STOP.

→ For details on the case of CPU STOP setting, refer to Subsection 6.3.5.

BFM No.		Description	R/W	Default
Hex.	Dec.			
#0DH	#13	0: Refresh 1: Clears compulsorily	R/W*1	K0

*1. "R/O" when set using network parameters.

Caution

When values other than 0 or 1 are set, "Refresh" operation is performed.

10.3.8 [BFM#16] Reserved station specification

Set remote stations and intelligent device stations which are included in the number of connected units but are not actually connected now so that such stations will not be handled as "data link faulty stations"

Set to ON the bits corresponding to the station numbers to be set as reserved.

→ For details on the reserved station specification, refer to Subsection 6.4.2.

BFM No.		Description	R/W	Default
Hex.	Dec.			
#10H	#16	Setting range: 0 to FFEH	R/W*1	K0

*1. "R/O" when set using network parameters.

Caution

- When a connected remote stations and intelligent device stations are set as a reserved station, the station cannot execute any data link at all.
- For a remote station or intelligent device station which occupies 2 or more stations, turn on only the bit for the station number set by the unit's station number setting switch.

10.3.9 [BFM#20] Error invalid station specification

Specify remote stations and intelligent device stations in which data link is disabled by power OFF, etc. so that they are not handled as "data link faulty stations" by the master station.

Set to ON the bits corresponding to the station numbers to be set as error invalid stations.

→ For details on the error invalid station specification, refer to Subsection 6.4.3.

BFM No.		Description	R/W	Default
Hex.	Dec.			
#14H	#20	Setting range: 0 to FFFFH	R/W*1	K0

*1. "R/O" when set using network parameters.

Caution

- For errors will not be detected at all in stations set as invalid stations.
- If a remote stations and intelligent device stations set as invalid station is also set as reserved station, the reserved station function has the priority.
- For a remote station or intelligent device station which occupies 2 or more stations, turn on only the bit for the station number set by the unit's station number setting switch.
- The error invalid station setting cannot be changed while online.

10.3.10 [BFM#32 to #47] Station information

Set the station type for connected remote stations, intelligent device stations and reserved stations.

BFM No.		Description	R/W	Default
Hex.	Dec.			
#20H to #2FH	#32 to #47	As shown below	R/W*1	*2

- *1. "R/O" when set using network parameters.
- *2. BFM#32 to #39: 0101H to 0108H, BFM#40 to #47: 0000H

1. The figure below shows the data configuration to be set

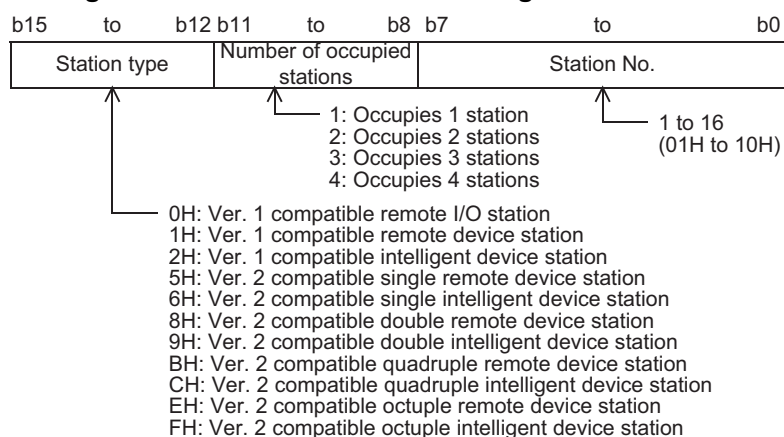

2. The table below shows the buffer memory address for each units.

For example, when setting for the 10th units, write the buffer memory address "BFM#41".

Unit	BFM No.		Unit	BFM No.	
	Hex.	Dec.		Hex.	Dec.
1st unit	#20H	#32	9th unit	#28H	#40
2nd unit	#21H	#33	10th unit	#29H	#41
3rd unit	#22H	#34	11th unit	#2AH	#42
4th unit	#23H	#35	12th unit	#2BH	#43
5th unit	#24H	#36	13th unit	#2CH	#44
6th unit	#25H	#37	14th unit	#2DH	#45
7th unit	#26H	#38	15th unit	#2EH	#46
8th unit	#27H	#39	16th unit	#2FH	#47

3. Setting example

The table below shows the system configuration and station information setting.

- System configuration

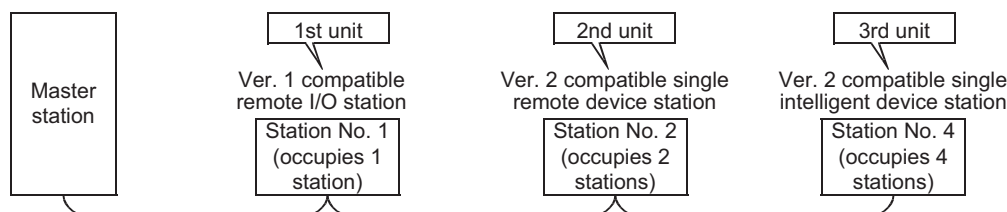

- Station information setting

BFM No.		Station type	Number of occupied stations	Station No.	Setting value
Hex.	Dec.				
#20H	#32	0H	1H	01H	0101H
#21H	#33	5H	2H	02H	5202H
#22H	#34	6H	4H	04H	6404H

10.4 I/O signals to PLC

This section describes I/O signals used to control the master block.

The signals used to control the master block are assigned to the buffer memory (BFM#10 and BFM#11) built in the FX3U-16CCL-M. The buffer memory of the same number works differently between the time of read (when the FROM instruction is used) and the time of write (when the TO instruction is used) as shown in the table below.

The system automatically changes over these functions in accordance with the instruction (FROM or TO).

Caution

- The output signals prohibited in the table below are used by the system, thus cannot be accessed by the user.
If used, normal operations cannot be guaranteed.
- Only reading is enabled when network parameters are used for setting.

I/O signals list

- PLC ← Master block : Read (when FROM instruction is used)

BFM No.		Bit	Input signal name
Hex.	Dec.		
#AH	#10	b0	Unit error
		b1	Data link status in master station
		b2	Parameter setting status
		b3	Data link status in other stations
		b4	Use prohibited
		b5	Use prohibited
		b6	Normal completion of data link startup by buffer memory parameters
		b7	Abnormal completion of data link startup by buffer memory parameters
		b8	Use prohibited
		b9	
		b10	
		b11	
		b12	
		b13	
		b14	Unit ready
		b15	
#BH	#11	b0	Use prohibited
		b1	
		b2	
		b3	
		b4	
		b5	
		b6	
		b7	
		b8	
		b9	
		b10	
		b11	
		b12	
		b13	
		b14	
		b15	

- PLC → Master block : Write (when TO instruction is used)

BFM No.		Bit	Output signal name
Hex.	Dec.		
#AH	#10	b0	Refresh command
		b1	Use prohibited
		b2	
		b3	
		b4	
		b5	
		b6	Request for data link startup by buffer memory parameters
		b7	Use prohibited
		b8	
		b9	
		b10	
		b11	
		b12	
		b13	
		b14	
b15			
#BH	#11	b0	Use prohibited
		b1	
		b2	
		b3	
		b4	
		b5	
		b6	
		b7	
		b8	
		b9	
		b10	
		b11	
		b12	
		b13	
		b14	
b15			

1	Introduction
2	Specification
3	System Configuration
4	Installation
5	Wiring
6	Introduction of Functions
7	Data Link Processing Time
8	Parameter Setting
9	Data Link Procedure
10	Buffer Memory

10.4.1 [BFM#10] Input signal details

1. Unit error (b0)

Indicates whether the unit is normal or not.
 OFF: The unit is normal.
 ON : The unit is abnormal.

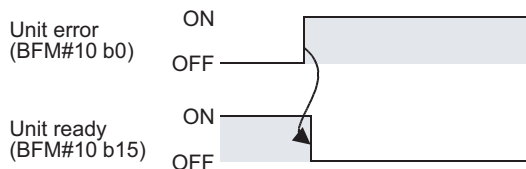

2. Data link status in master station (b1)

Indicates the data link status in the master station.
 OFF: Data link is stopped.
 ON : Data link is in progress.

3. Parameter setting status (b2)

Indicates the parameter setting status in the master station.
 The signal SB006D has the same meaning.
 OFF: The setting is normal.
 ON : There is an error in the setting. (The error code is stored in SW0068.)
 This signal turns OFF when the write request for data link startup by buffer memory parameters (BFM#10 b6) in which no error has occurred.

4. Data link status in other stations (b3)

Indicates the data link status at other stations (remote stations and intelligent device stations).
 The signal SB0080 has the same meaning.
 OFF: All stations are normal.
 ON : There is an error in some stations. (The error station status is stored in SW0080.)

Caution

The other station data link status takes up to 6 seconds to turn ON after a slave station connected to the master station becomes faulty. The time to turn ON differs according to the system configuration, faulty status or other conditions.

5. Normal completion of data link startup by buffer memory parameters (b6)

Indicates the normal completion status of the data link startup request by the write request for data link startup by buffer memory parameters (BFM#10 b6).

- 1) When the write request for data link startup by buffer memory parameters (BFM#10 b6) is set to ON, the contents of the buffer memory parameters are checked. When the contents are normal, the system automatically starts data link.
- 2) When data link startup is normally completed, the read data link startup normal completion (BFM#10 b6) turns ON.
- 3) When the write request for data link startup by buffer memory parameters (BFM#10 b6) is set to OFF, the read normal completion of data link startup by buffer memory parameters (BFM#10 b6) turns OFF.

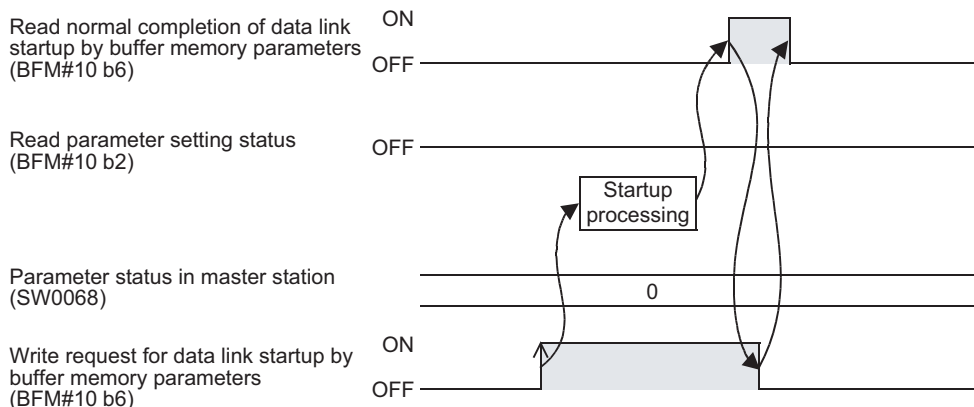

6. Abnormal completion of data link startup by buffer memory parameters (b7)

Indicates the abnormal completion status of the data link startup request by the write request for data link startup by buffer memory parameters (BFM#10 b6).

- 1) When the write request for data link startup by buffer memory parameters (BFM#10 b6) is set to ON, the contents of the buffer memory are checked. When the contents are abnormal, the read abnormal completion of data link startup by buffer memory parameters (BFM#10 b7) turns ON.
- 2) The parameter setting status (BFM#10 b2) turns ON, and the error code is stored in the buffer memory for the parameter status in master station (SW0068).
- 3) When the write request for data link startup by buffer memory parameters (BFM#10 b6) is set to OFF, the read abnormal completion of data link startup by buffer memory parameters (BFM#10 b7) turns OFF.

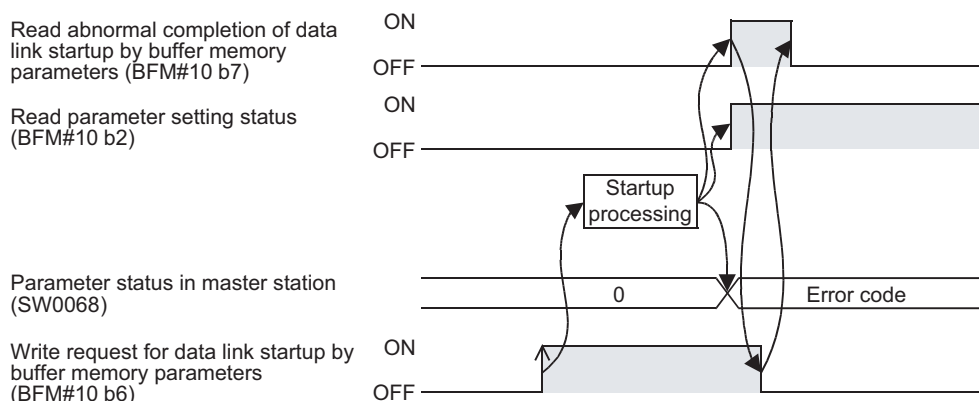

7. Unit ready (b15)

Indicates whether or not the unit is ready for operation.

- 1) The signal automatically turns ON when the unit becomes ready for operation.
- 2) The signal turns OFF when one of the following conditions occur:
 - There is an error in the unit switch settings.
 - The input signal of unit error (BFM#10 b0) turns ON.

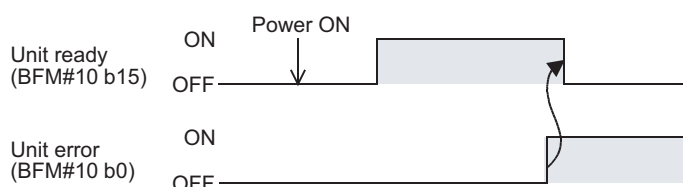

1	Introduction
2	Specification
3	System Configuration
4	Installation
5	Wiring
6	Introduction of Functions
7	Data Link Processing Time
8	Parameter Setting
9	Data Link Procedure
10	Buffer Memory

10.4.2 [BFM#10] Output signal

1. Refresh command (b0)

Indicates whether or not the contents of the buffer memory for "remote output RY (BFM#352 to #383, BFM#16896 to #16927)" are valid.

OFF: Not effective (Sends all OFF data.)

ON : Effective (Sends the data in "remote output (BFM#352 to #383, BFM#16896 to #16927)" in the buffer memory.)

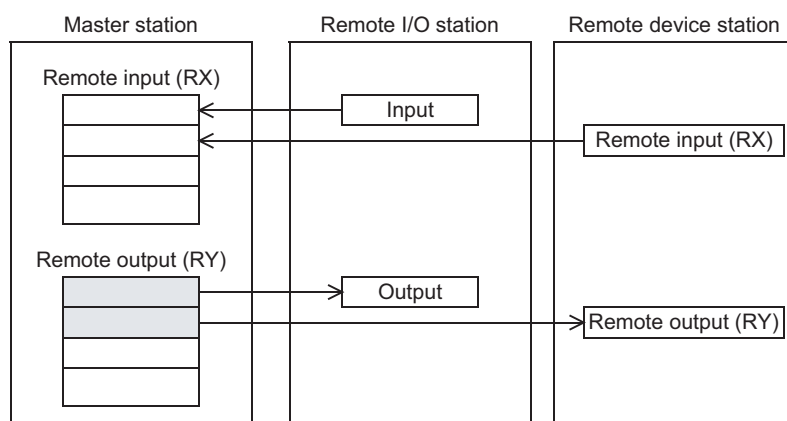

Caution

- Set to ON the write refresh command (BFM#10 b0) before starting up the data link.
- When the master station PLC is in the stop status, the write refresh command (BFM#10 b0) turns OFF.
- When output signals are set using network parameters, they are refreshed without regard to the setting of "Refresh command (BFM#10 b0)".

2. Request for data link startup by buffer memory parameters (b6)

Starts up the data link in accordance with the contents of the parameters in the buffer memory.

For the signal timing, refer to Subsection 10.4.1.5) and 6).

Caution

When the parameter outside a setting range is set up, it becomes a parameter error and a data link can not startup.

10.4.3 [BFM#14] Output signal monitor

Output signal monitor (BFM#14) can read the status set to the Input signal (BFM#10).

For details, refer to the Input signal (BFM#10) write value.

10.5 Master Block Control Signals

10.5.1 [BFM#29] Error code

This buffer memory address stores error code information for the FX3U-16CCL-M.
The following meaning is assigned to the error code handled as the ON/OFF information of bit 0 to bit 15.

BFM#29 Error code		
Bit	Description	Explanation
b0	BFM accessibility error	OFF: No error ON: This bit turns ON when the executed TO instruction specifies an area set by network parameters, unavailable area, unassigned remote I/O (RX/Ry) area or remote register (RWw/RWr) area. Communication state: Continuation Action: Please check the PLC program. To reset this bit, write "K0" to BFM #29.
b1	Transmission rate setting error	OFF: No errors in the setting ON: The rotary switch is set outside the allowable setting range.
b2	Station number setting error	Communication state: Stop Action: Please check the setting of the rotary switch.
b3	Reserved	0 (Not used)
b4	Reserved	0 (Not used)
b5	Transmission rate change error	OFF: No setting change ON: This bit turns ON when the rotary switch setting is changed after the FX3U-16CCL-M is started, and turns OFF when the rotary switch is returned to its previous setting.
b6	Station number change error	Communication state: Continuation Action: Please check the setting of the rotary switch.
b7	Reserved	0 (Not used)
b8	Errors in internal communication power supply	OFF: No error ON: Inside communication power supply error Communication state: Stop Action: For repair, contact your local Mitsubishi Electric representative.
b9	Hardware error	OFF: No error ON: Hardware error Communication state: Stop Action: For repair, contact your local Mitsubishi Electric representative.
b10	Unit status	OFF: Normal ON: Abnormal Data cannot be transferred normally to/from the main unit. Communication state: Stop
b11	Master station operation status	OFF: Normal ON: Abnormal Communication state: Continuation or stop
b12	Transient transmission status	OFF: No error ON: Error (SB0094) Communication state: Continuation or stop
b13	Main unit initialization status	OFF: Main unit initialization completed ON : Main unit initialization not completed This bit turns ON when the main unit is not powered, or when there is a power failure in the FX3U-16CCL-M. Communication state: Continuation or stop
b14	Reserved	0 (Not used)
b15	Reserved	0 (Not used)

1

Introduction

2

Specification

3

System Configuration

4

Installation

5

Wiring

6

Introduction of Functions

7

Data Link Processing Time

8

Parameter Setting

9

Data Link Procedure

10

Buffer Memory

10.5.2 [BFM#30] FX Series model code

The model code of the FX3U-16CCL-M (K7530) is stored.

BFM No.		Description	R/W	Initial value
Hex.	Dec.			
#1EH	#30	The model code of the FX3U-16CCL-M is K7530	R/O	K7530

10.6 [BFM#220 to #223] Consistency control

Use these buffer memory addresses for consistency control to send or receive link data composed of 1 word (16 bits) or more or 2 words (32 bits) or more.

These buffer memory addresses assure data consistency for 1 word (16 bits) or more when read or written by the FROM/TO instructions, or data consistency for 2 words (32 bits) or more when read or written by the DFROM/DTO instructions.

→ For details on the consistency control, refer to Subsection 6.3.6.

BFM No.		Description	Explanation	R/W
Hex.	Dec.			
#DCH	#220	RX area consistency flag	Consistency control 1: Consistency accessibility start Set the latest data, and stop the buffer memory from being refreshed. 0: Data consistency accessibility is completed or not used. ("0" is the initial value.) Refresh the communication data and buffer memory as required. (When a device changes from "1" to "0", the unit resumes refreshing the communication data and buffer memory.) When any other number is set, these devices do not control the consistency in the same way as "0".	R/W
#DDH	#221	RY area consistency flag		R/W
#DEH	#222	RWw area consistency flag		R/W
#DFH	#223	RWr area consistency flag		R/W

10.7 [BFM#224 to #255] Remote Input (RX)

Used when the remote net ver. 1 mode or remote net additional mode is selected.

The input status from remote I/O stations, remote device stations and intelligent device stations are stored. Each station uses 2 words.

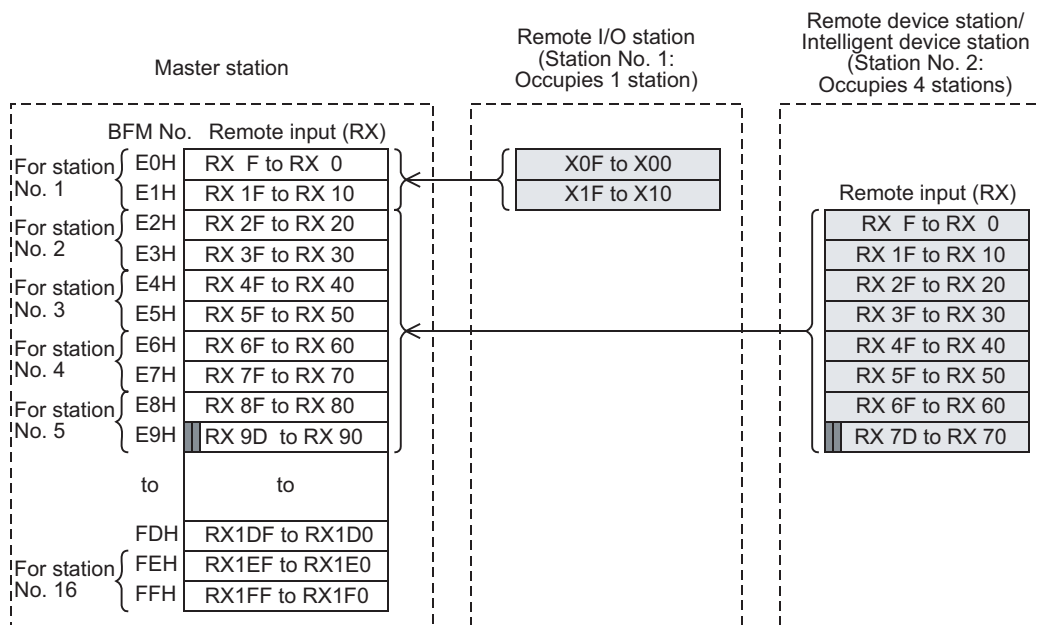

▬ : The last two bits cannot be used in the communication between the master and intelligent device stations. (In the example above, RX9E and RX9F cannot be used.)

Caution

- When the TO instruction (or direct buffer memory specification) is executed, writing is invalid. When the FROM instruction (or direct buffer memory specification) is executed for reading from an area without assigned link points, the reading operation results in "0" being read.
- The last two bits cannot be used in the communication between the master and intelligent device stations.
- The upper 16bits (1 word) in the last station of remote stations and intelligent device stations is occupied as a system area. For details, refer to the each unit's manuals.

Correspondence among BFM No. in master station, station number and remote input (RX)

Station No.	BFM No.	b15	b14	b13	b12	b11	b10	b9	b8	b7	b6	b5	b4	b3	b2	b1	b0
1	E0H	RX F	RX E	RX D	RX C	RX B	RX A	RX 9	RX 8	RX 7	RX 6	RX 5	RX 4	RX 3	RX 2	RX 1	RX 0
	E1H	RX 1F	RX 1E	RX 1D	RX 1C	RX 1B	RX 1A	RX 19	RX 18	RX 17	RX 16	RX 15	RX 14	RX 13	RX 12	RX 11	RX 10
2	E2H	RX 2F	RX 2E	RX 2D	RX 2C	RX 2B	RX 2A	RX 29	RX 28	RX 27	RX 26	RX 25	RX 24	RX 23	RX 22	RX 21	RX 20
	E3H	RX 3F	RX 3E	RX 3D	RX 3C	RX 3B	RX 3A	RX 39	RX 38	RX 37	RX 36	RX 35	RX 34	RX 33	RX 32	RX 31	RX 30
3	E4H	RX 4F	RX 4E	RX 4D	RX 4C	RX 4B	RX 4A	RX 49	RX 48	RX 47	RX 46	RX 45	RX 44	RX 43	RX 42	RX 41	RX 40
	E5H	RX 5F	RX 5E	RX 5D	RX 5C	RX 5B	RX 5A	RX 59	RX 58	RX 57	RX 56	RX 55	RX 54	RX 53	RX 52	RX 51	RX 50
4	E6H	RX 6F	RX 6E	RX 6D	RX 6C	RX 6B	RX 6A	RX 69	RX 68	RX 67	RX 66	RX 65	RX 64	RX 63	RX 62	RX 61	RX 60
	E7H	RX 7F	RX 7E	RX 7D	RX 7C	RX 7B	RX 7A	RX 79	RX 78	RX 77	RX 76	RX 75	RX 74	RX 73	RX 72	RX 71	RX 70
5	E8H	RX 8F	RX 8E	RX 8D	RX 8C	RX 8B	RX 8A	RX 89	RX 88	RX 87	RX 86	RX 85	RX 84	RX 83	RX 82	RX 81	RX 80
	E9H	RX 9F	RX 9E	RX 9D	RX 9C	RX 9B	RX 9A	RX 99	RX 98	RX 97	RX 96	RX 95	RX 94	RX 93	RX 92	RX 91	RX 90
6	EAH	RX AF	RX AE	RX AD	RX AC	RX AB	RX AA	RX A9	RX A8	RX A7	RX A6	RX A5	RX A4	RX A3	RX A2	RX A1	RX A0
	EBH	RX BF	RX BE	RX BD	RX BC	RX BB	RX BA	RX B9	RX B8	RX B7	RX B6	RX B5	RX B4	RX B3	RX B2	RX B1	RX B0
7	ECH	RX CF	RX CE	RX CD	RX CC	RX CB	RX CA	RX C9	RX C8	RX C7	RX C6	RX C5	RX C4	RX C3	RX C2	RX C1	RX C0
	EDH	RX DF	RX DE	RX DD	RX DC	RX DB	RX DA	RX D9	RX D8	RX D7	RX D6	RX D5	RX D4	RX D3	RX D2	RX D1	RX D0
8	EEH	RX EF	RX EE	RX ED	RX EC	RX EB	RX EA	RX E9	RX E8	RX E7	RX E6	RX E5	RX E4	RX E3	RX E2	RX E1	RX E0
	EFH	RX FF	RX FE	RX FD	RX FC	RX FB	RX FA	RX F9	RX F8	RX F7	RX F6	RX F5	RX F4	RX F3	RX F2	RX F1	RX F0
9	F0H	RX 10F	RX 10E	RX 10D	RX 10C	RX 10B	RX 10A	RX 109	RX 108	RX 107	RX 106	RX 105	RX 104	RX 103	RX 102	RX 101	RX 100
	F1H	RX 11F	RX 11E	RX 11D	RX 11C	RX 11B	RX 11A	RX 119	RX 118	RX 117	RX 116	RX 115	RX 114	RX 113	RX 112	RX 111	RX 110
10	F2H	RX 12F	RX 12E	RX 12D	RX 12C	RX 12B	RX 12A	RX 129	RX 128	RX 127	RX 126	RX 125	RX 124	RX 123	RX 122	RX 121	RX 120
	F3H	RX 13F	RX 13E	RX 13D	RX 13C	RX 13B	RX 13A	RX 139	RX 138	RX 137	RX 136	RX 135	RX 134	RX 133	RX 132	RX 131	RX 130
11	F4H	RX 14F	RX 14E	RX 14D	RX 14C	RX 14B	RX 14A	RX 149	RX 148	RX 147	RX 146	RX 145	RX 144	RX 143	RX 142	RX 141	RX 140
	F5H	RX 15F	RX 15E	RX 15D	RX 15C	RX 15B	RX 15A	RX 159	RX 158	RX 157	RX 156	RX 155	RX 154	RX 153	RX 152	RX 151	RX 150
12	F6H	RX 16F	RX 16E	RX 16D	RX 16C	RX 16B	RX 16A	RX 169	RX 168	RX 167	RX 166	RX 165	RX 164	RX 163	RX 162	RX 161	RX 160
	F7H	RX 17F	RX 17E	RX 17D	RX 17C	RX 17B	RX 17A	RX 179	RX 178	RX 177	RX 176	RX 175	RX 174	RX 173	RX 172	RX 171	RX 170
13	F8H	RX 18F	RX 18E	RX 18D	RX 18C	RX 18B	RX 18A	RX 189	RX 188	RX 187	RX 186	RX 185	RX 184	RX 183	RX 182	RX 181	RX 180
	F9H	RX 19F	RX 19E	RX 19D	RX 19C	RX 19B	RX 19A	RX 199	RX 198	RX 197	RX 196	RX 195	RX 194	RX 193	RX 192	RX 191	RX 190
14	FAH	RX 1AF	RX 1AE	RX 1AD	RX 1AC	RX 1AB	RX 1AA	RX 1A9	RX 1A8	RX 1A7	RX 1A6	RX 1A5	RX 1A4	RX 1A3	RX 1A2	RX 1A1	RX 1A0
	FBH	RX 1BF	RX 1BE	RX 1BD	RX 1BC	RX 1BB	RX 1BA	RX 1B9	RX 1B8	RX 1B7	RX 1B6	RX 1B5	RX 1B4	RX 1B3	RX 1B2	RX 1B1	RX 1B0
15	FCH	RX 1CF	RX 1CE	RX 1CD	RX 1CC	RX 1CB	RX 1CA	RX 1C9	RX 1C8	RX 1C7	RX 1C6	RX 1C5	RX 1C4	RX 1C3	RX 1C2	RX 1C1	RX 1C0
	FDH	RX 1DF	RX 1DE	RX 1DD	RX 1DC	RX 1DB	RX 1DA	RX 1D9	RX 1D8	RX 1D7	RX 1D6	RX 1D5	RX 1D4	RX 1D3	RX 1D2	RX 1D1	RX 1D0
16	FEH	RX 1EF	RX 1EE	RX 1ED	RX 1EC	RX 1EB	RX 1EA	RX 1E9	RX 1E8	RX 1E7	RX 1E6	RX 1E5	RX 1E4	RX 1E3	RX 1E2	RX 1E1	RX 1E0
	FFH	RX 1FF	RX 1FE	RX 1FD	RX 1FC	RX 1FB	RX 1FA	RX 1F9	RX 1F8	RX 1F7	RX 1F6	RX 1F5	RX 1F4	RX 1F3	RX 1F2	RX 1F1	RX 1F0

10.8 [BFM#352 to #383] Remote Output (RY)

Used when the remote net ver. 1 mode or remote net additional mode is selected.
The output status from remote I/O stations, remote device stations and intelligent device stations are stored.
Each station uses 2 words.

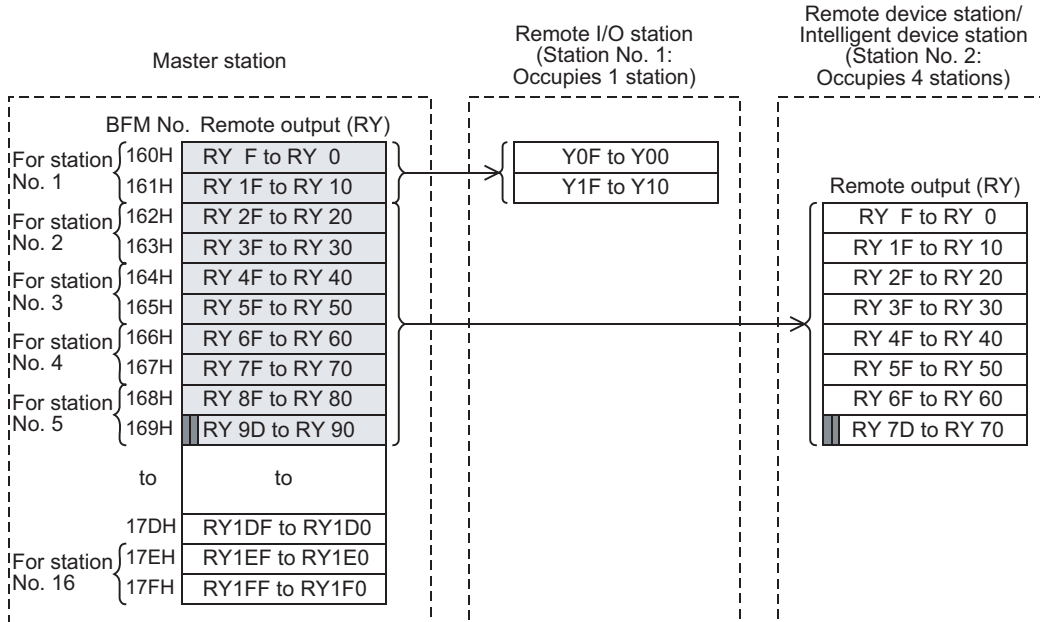

▬ : The last two bits cannot be used in the communication between the master and intelligent device stations.
(In the example above, RY9E and RY9F cannot be used.)

Caution

- When the TO instruction (or direct buffer memory specification) is executed for writing to an area without assigned link points, writing is invalid.
When the FROM instruction (or direct buffer memory specification) is executed for reading from an area without assigned link points, the reading operation results in "0" being read.
- The last two bits cannot be used in the communication between the master and intelligent device stations.
- The upper 16bits (1 word) in the last station of remote stations and intelligent device stations is occupied as a system area. For details, refer to the each unit's manuals.

Correspondence among BFM No. in master station, station number and remote output (RY) number

Station No.	BFM No.	b15	b14	b13	b12	b11	b10	b9	b8	b7	b6	b5	b4	b3	b2	b1	b0
1	160H	RY F	RY E	RY D	RY C	RY B	RY A	RY 9	RY 8	RY 7	RY 6	RY 5	RY 4	RY 3	RY 2	RY 1	RY 0
	161H	RY 1F	RY 1E	RY 1D	RY 1C	RY 1B	RY 1A	RY 19	RY 18	RY 17	RY 16	RY 15	RY 14	RY 13	RY 12	RY 11	RY 10
2	162H	RY 2F	RY 2E	RY 2D	RY 2C	RY 2B	RY 2A	RY 29	RY 28	RY 27	RY 26	RY 25	RY 24	RY 23	RY 22	RY 21	RY 20
	163H	RY 3F	RY 3E	RY 3D	RY 3C	RY 3B	RY 3A	RY 39	RY 38	RY 37	RY 36	RY 35	RY 34	RY 33	RY 32	RY 31	RY 30
3	164H	RY 4F	RY 4E	RY 4D	RY 4C	RY 4B	RY 4A	RY 49	RY 48	RY 47	RY 46	RY 45	RY 44	RY 43	RY 42	RY 41	RY 40
	165H	RY 5F	RY 5E	RY 5D	RY 5C	RY 5B	RY 5A	RY 59	RY 58	RY 57	RY 56	RY 55	RY 54	RY 53	RY 52	RY 51	RY 50
4	166H	RY 6F	RY 6E	RY 6D	RY 6C	RY 6B	RY 6A	RY 69	RY 68	RY 67	RY 66	RY 65	RY 64	RY 63	RY 62	RY 61	RY 60
	167H	RY 7F	RY 7E	RY 7D	RY 7C	RY 7B	RY 7A	RY 79	RY 78	RY 77	RY 76	RY 75	RY 74	RY 73	RY 72	RY 71	RY 70
5	168H	RY 8F	RY 8E	RY 8D	RY 8C	RY 8B	RY 8A	RY 89	RY 88	RY 87	RY 86	RY 85	RY 84	RY 83	RY 82	RY 81	RY 80
	169H	RY 9F	RY 9E	RY 9D	RY 9C	RY 9B	RY 9A	RY 99	RY 98	RY 97	RY 96	RY 95	RY 94	RY 93	RY 92	RY 91	RY 90
6	16AH	RY AF	RY AE	RY AD	RY AC	RY AB	RY AA	RY A9	RY A8	RY A7	RY A6	RY A5	RY A4	RY A3	RY A2	RY A1	RY A0
	16BH	RY BF	RY BE	RY BD	RY BC	RY BB	RY BA	RY B9	RY B8	RY B7	RY B6	RY B5	RY B4	RY B3	RY B2	RY B1	RY B0
7	16CH	RY CF	RY CE	RY CD	RY CC	RY CB	RY CA	RY C9	RY C8	RY C7	RY C6	RY C5	RY C4	RY C3	RY C2	RY C1	RY C0
	16DH	RY DF	RY DE	RY DD	RY DC	RY DB	RY DA	RY D9	RY D8	RY D7	RY D6	RY D5	RY D4	RY D3	RY D2	RY D1	RY D0
8	16EH	RY EF	RY EE	RY ED	RY EC	RY EB	RY EA	RY E9	RY E8	RY E7	RY E6	RY E5	RY E4	RY E3	RY E2	RY E1	RY E0
	16FH	RY FF	RY FE	RY FD	RY FC	RY FB	RY FA	RY F9	RY F8	RY F7	RY F6	RY F5	RY F4	RY F3	RY F2	RY F1	RY F0
9	170H	RY 10F	RY 10E	RY 10D	RY 10C	RY 10B	RY 10A	RY 109	RY 108	RY 107	RY 106	RY 105	RY 104	RY 103	RY 102	RY 101	RY 100
	171H	RY 11F	RY 11E	RY 11D	RY 11C	RY 11B	RY 11A	RY 119	RY 118	RY 117	RY 116	RY 115	RY 114	RY 113	RY 112	RY 111	RY 110
10	172H	RY 12F	RY 12E	RY 12D	RY 12C	RY 12B	RY 12A	RY 129	RY 128	RY 127	RY 126	RY 125	RY 124	RY 123	RY 122	RY 121	RY 120
	173H	RY 13F	RY 13E	RY 13D	RY 13C	RY 13B	RY 13A	RY 139	RY 138	RY 137	RY 136	RY 135	RY 134	RY 133	RY 132	RY 131	RY 130
11	174H	RY 14F	RY 14E	RY 14D	RY 14C	RY 14B	RY 14A	RY 149	RY 148	RY 147	RY 146	RY 145	RY 144	RY 143	RY 142	RY 141	RY 140
	175H	RY 15F	RY 15E	RY 15D	RY 15C	RY 15B	RY 15A	RY 159	RY 158	RY 157	RY 156	RY 155	RY 154	RY 153	RY 152	RY 151	RY 150
12	176H	RY 16F	RY 16E	RY 16D	RY 16C	RY 16B	RY 16A	RY 169	RY 168	RY 167	RY 166	RY 165	RY 164	RY 163	RY 162	RY 161	RY 160
	177H	RY 17F	RY 17E	RY 17D	RY 17C	RY 17B	RY 17A	RY 179	RY 178	RY 177	RY 176	RY 175	RY 174	RY 173	RY 172	RY 171	RY 170
13	178H	RY 18F	RY 18E	RY 18D	RY 18C	RY 18B	RY 18A	RY 189	RY 188	RY 187	RY 186	RY 185	RY 184	RY 183	RY 182	RY 181	RY 180
	179H	RY 19F	RY 19E	RY 19D	RY 19C	RY 19B	RY 19A	RY 199	RY 198	RY 197	RY 196	RY 195	RY 194	RY 193	RY 192	RY 191	RY 190
14	17AH	RY 1AF	RY 1AE	RY 1AD	RY 1AC	RY 1AB	RY 1AA	RY 1A9	RY 1A8	RY 1A7	RY 1A6	RY 1A5	RY 1A4	RY 1A3	RY 1A2	RY 1A1	RY 1A0
	17BH	RY 1BF	RY 1BE	RY 1BD	RY 1BC	RY 1BB	RY 1BA	RY 1B9	RY 1B8	RY 1B7	RY 1B6	RY 1B5	RY 1B4	RY 1B3	RY 1B2	RY 1B1	RY 1B0
15	17CH	RY 1CF	RY 1CE	RY 1CD	RY 1CC	RY 1CB	RY 1CA	RY 1C9	RY 1C8	RY 1C7	RY 1C6	RY 1C5	RY 1C4	RY 1C3	RY 1C2	RY 1C1	RY 1C0
	17DH	RY 1DF	RY 1DE	RY 1DD	RY 1DC	RY 1DB	RY 1DA	RY 1D9	RY 1D8	RY 1D7	RY 1D6	RY 1D5	RY 1D4	RY 1D3	RY 1D2	RY 1D1	RY 1D0
16	17EH	RY 1EF	RY 1EE	RY 1ED	RY 1EC	RY 1EB	RY 1EA	RY 1E9	RY 1E8	RY 1E7	RY 1E6	RY 1E5	RY 1E4	RY 1E3	RY 1E2	RY 1E1	RY 1E0
	17FH	RY 1FF	RY 1FE	RY 1FD	RY 1FC	RY 1FB	RY 1FA	RY 1F9	RY 1F8	RY 1F7	RY 1F6	RY 1F5	RY 1F4	RY 1F3	RY 1F2	RY 1F1	RY 1F0

10.9 [BFM#480 to #543] Remote registers (RWw)

Used when the remote net ver. 1 mode or remote net additional mode is selected.
 The data transmitted to the remote register (RWw) in remote device stations and intelligent device stations is stored as below.
 Each station uses 4 words.

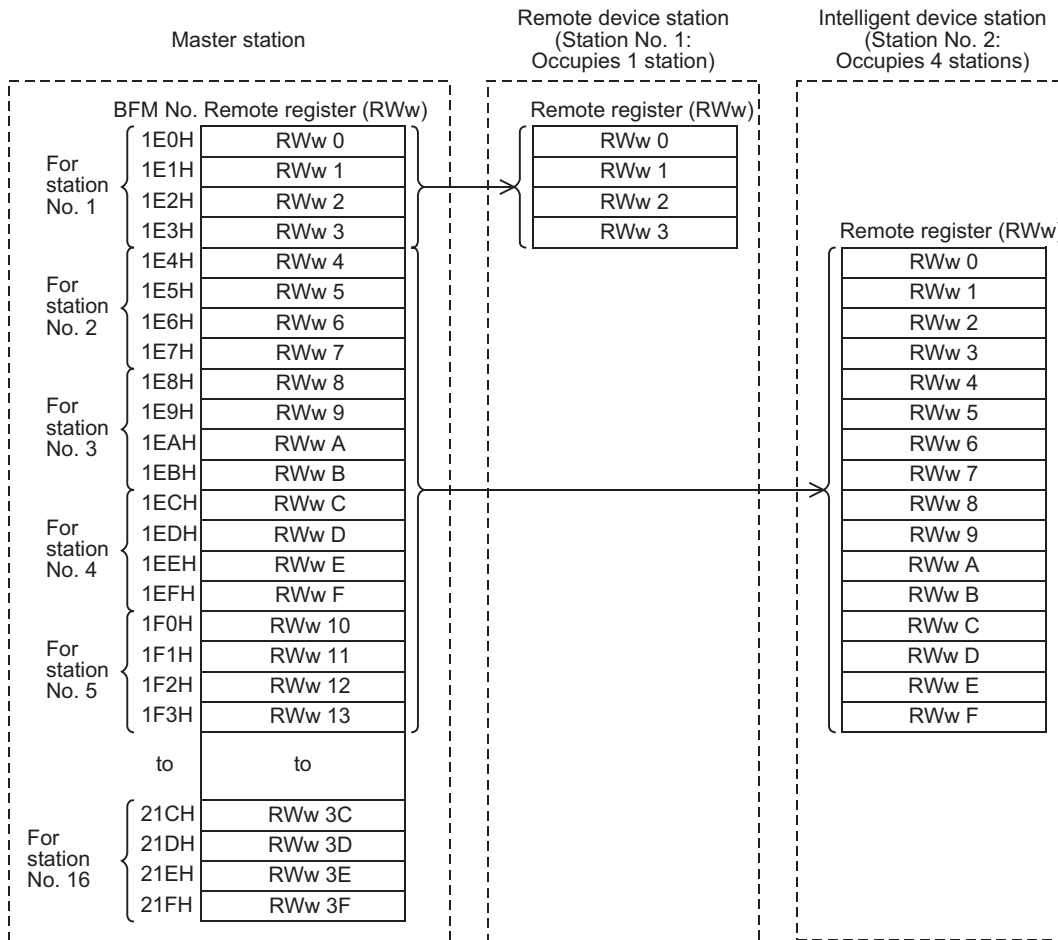

Caution

- When the TO instruction (or direct buffer memory specification) is executed for writing to an area without assigned link points, writing is invalid.
 When the FROM instruction (or direct buffer memory specification) is executed for reading from an area without assigned link points, the reading operation results in "0" being read.

1	Introduction
2	Specification
3	System Configuration
4	Installation
5	Wiring
6	Introduction of Functions
7	Data Link Processing Time
8	Parameter Setting
9	Data Link Procedure
10	Buffer Memory

Correspondence among BFM No. in master station, station number and remote register (RWw) number

Station No.	BFM No.	Remote register No.
1	1E0H	RWw 0
	1E1H	RWw 1
	1E2H	RWw 2
	1E3H	RWw 3
2	1E4H	RWw 4
	1E5H	RWw 5
	1E6H	RWw 6
	1E7H	RWw 7
3	1E8H	RWw 8
	1E9H	RWw 9
	1EAH	RWw A
	1EBH	RWw B
4	1ECH	RWw C
	1EDH	RWw D
	1EEH	RWw E
	1EFH	RWw F
5	1F0H	RWw 10
	1F1H	RWw 11
	1F2H	RWw 12
	1F3H	RWw 13
6	1F4H	RWw 14
	1F5H	RWw 15
	1F6H	RWw 16
	1F7H	RWw 17
7	1F8H	RWw 18
	1F9H	RWw 19
	1FAH	RWw 1A
	1FBH	RWw 1B
8	1FCH	RWw 1C
	1FDH	RWw 1D
	1FEH	RWw 1E
	1FFH	RWw 1F

Station No.	BFM No.	Remote register No.
9	200H	RWw 20
	201H	RWw 21
	202H	RWw 22
	203H	RWw 23
10	204H	RWw 24
	205H	RWw 25
	206H	RWw 26
	207H	RWw 27
11	208H	RWw 28
	209H	RWw 29
	20AH	RWw 2A
	20BH	RWw 2B
12	20CH	RWw 2C
	20DH	RWw 2D
	20EH	RWw 2E
	20FH	RWw 2F
13	210H	RWw 30
	211H	RWw 31
	212H	RWw 32
	213H	RWw 33
14	214H	RWw 34
	215H	RWw 35
	216H	RWw 36
	217H	RWw 37
15	218H	RWw 38
	219H	RWw 39
	21AH	RWw 3A
	21BH	RWw 3B
16	21CH	RWw 3C
	21DH	RWw 3D
	21EH	RWw 3E
	21FH	RWw 3F

10.10 [BFM#736 to #799] Remote registers (RWr)

Used when the remote net ver. 1 mode or remote net additional mode is selected.
 The data transmitted from the remote register (RWr) in remote device stations and intelligent device stations is stored as below.
 Each station uses 4 words.

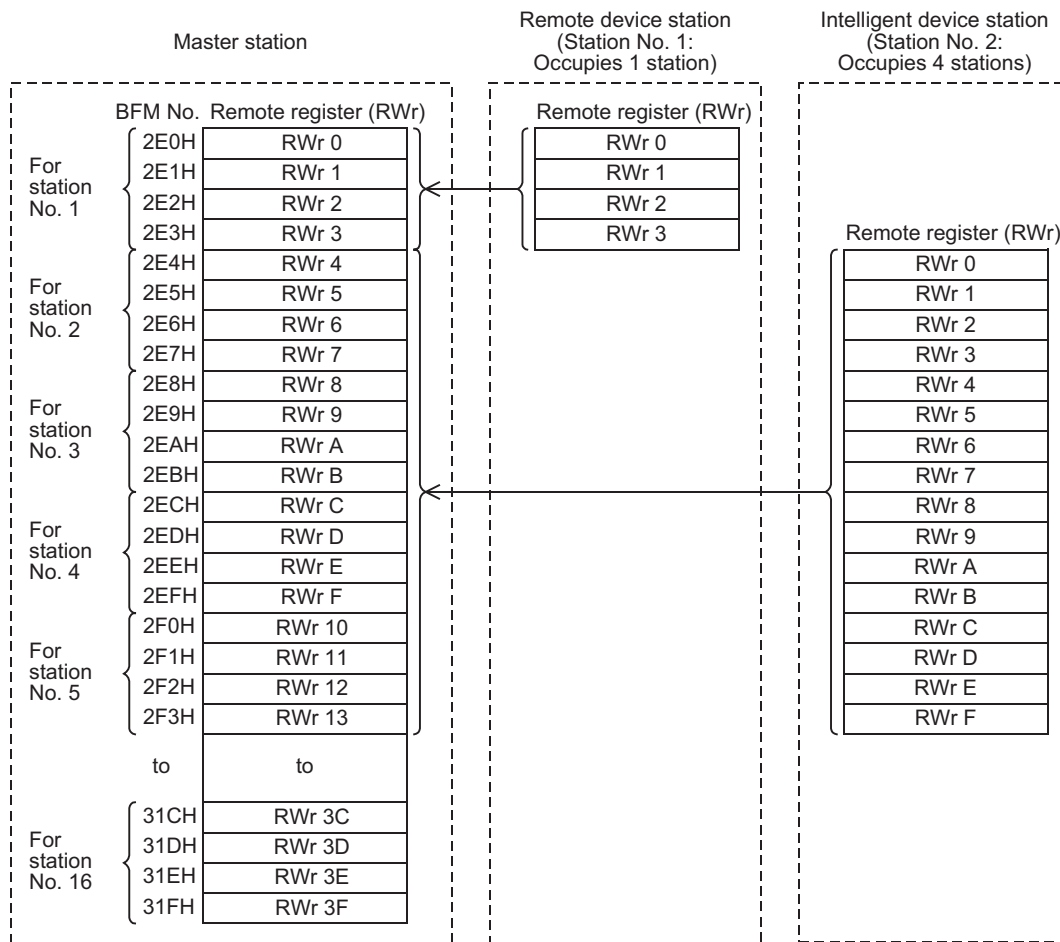

Caution

- When the TO instruction (or direct buffer memory specification) is executed, writing is invalid. When the FROM instruction (or direct buffer memory specification) is executed for reading from an area without assigned link points, the reading operation results in "0" being read.

1	Introduction
2	Specification
3	System Configuration
4	Installation
5	Wiring
6	Introduction of Functions
7	Data Link Processing Time
8	Parameter Setting
9	Data Link Procedure
10	Buffer Memory

Correspondence among BFM No. in master station, station number and remote register (RWr) number

Station No.	BFM No.	Remote register No.
1	2E0H	RWr 0
	2E1H	RWr 1
	2E2H	RWr 2
	2E3H	RWr 3
2	2E4H	RWr 4
	2E5H	RWr 5
	2E6H	RWr 6
	2E7H	RWr 7
3	2E8H	RWr 8
	2E9H	RWr 9
	2EAH	RWr A
	2EBH	RWr B
4	2ECH	RWr C
	2EDH	RWr D
	2EEH	RWr E
	2EFH	RWr F
5	2F0H	RWr 10
	2F1H	RWr 11
	2F2H	RWr 12
	2F3H	RWr 13
6	2F4H	RWr 14
	2F5H	RWr 15
	2F6H	RWr 16
	2F7H	RWr 17
7	2F8H	RWr 18
	2F9H	RWr 19
	2FAH	RWr 1A
	2FBH	RWr 1B
8	2FCH	RWr 1C
	2FDH	RWr 1D
	2FEH	RWr 1E
	2FFH	RWr 1F

Station No.	BFM No.	Remote register No.
9	300H	RWr 20
	301H	RWr 21
	302H	RWr 22
	303H	RWr 23
10	304H	RWr 24
	305H	RWr 25
	306H	RWr 26
	307H	RWr 27
11	308H	RWr 28
	309H	RWr 29
	30AH	RWr 2A
	30BH	RWr 2B
12	30CH	RWr 2C
	30DH	RWr 2D
	30EH	RWr 2E
	30FH	RWr 2F
13	310H	RWr 30
	311H	RWr 31
	312H	RWr 32
	313H	RWr 33
14	314H	RWr 34
	315H	RWr 35
	316H	RWr 36
	317H	RWr 37
15	318H	RWr 38
	319H	RWr 39
	31AH	RWr 3A
	31BH	RWr 3B
16	31CH	RWr 3C
	31DH	RWr 3D
	31EH	RWr 3E
	31FH	RWr 3F

10.11 [BFM#992 to #1503] Slave Station Offset, Size Information

In the remote net ver. 2 mode or remote net additional mode, the assignment of RX/Ry/RWw/RWr for the station numbers varies according to the expanded cyclic setting.

- **Offset**
Stores the head buffer memory No. of RX/Ry/RWw/RWr assigned to each station.
When 2 or more stations are occupied, values are stored into only the head buffer No. address of the station number.
(For example, when station No. 1 occupies 2 stations, values are stored with the RX/Ry/RWw/RWr offset and size of station No. 1, and the RX/Ry/RWw/RWr offset and size of station No. 2 remains at the initial value "0000H".)
- **Size**
Stores the size of RX/Ry/RWw/RWr assigned to each station in word units. For the reserved station, 0000H is stored.

Caution

For remote net ver. 1 mode, offset and size remains at the initial value 0000H.

Correspondence between station numbers and RX/Ry/RWw/RWr offset, size buffer memory No.

BFM No.		Item	R/W	Initial value
Hex.	Dec.			
#3E0H	#992	Station No. 1 RX offset	R/O	0000H
#3E1H	#993	Station No. 1 RX size	R/O	0000H
#3E2H	#994	Station No. 2 RX offset	R/O	0000H
#3E3H	#995	Station No. 2 RX size	R/O	0000H
to	to	to	to	to
#3FEH	#1022	Station No. 16 RX offset	R/O	0000H
#3FFH	#1023	Station No. 16 RX size	R/O	0000H
#400H to #45FH	#1024 to #1119	Use prohibited	-	-
#460H	#1120	Station No. 1 RY offset	R/O	0000H
#461H	#1121	Station No. 1 RY size	R/O	0000H
#462H	#1122	Station No. 2 RY offset	R/O	0000H
#463H	#1123	Station No. 2 RY size	R/O	0000H
to	to	to	to	to
#47EH	#1150	Station No. 16 RY offset	R/O	0000H
#47FH	#1151	Station No. 16 RY size	R/O	0000H
#480H to #4DFH	#1152 to #1247	Use prohibited	-	-
#4E0H	#1248	Station No. 1 RWw offset	R/O	0000H
#4E1H	#1249	Station No. 1 RWw size	R/O	0000H
#4E2H	#1250	Station No. 2 RWw offset	R/O	0000H
#4E3H	#1251	Station No. 2 RWw size	R/O	0000H
to	to	to	to	to
#4FEH	#1278	Station No. 16 RWw offset	R/O	0000H
#4FFH	#1279	Station No. 16 RWw size	R/O	0000H
#500H to #55FH	#1280 to #1375	Use prohibited	-	-
#560H	#1376	Station No. 1 RWr offset	R/O	0000H
#561H	#1377	Station No. 1 RWr size	R/O	0000H
#562H	#1378	Station No. 2 RWr offset	R/O	0000H
#563H	#1379	Station No. 2 RWr size	R/O	0000H
to	to	to	to	to
#57EH	#1406	Station No. 16 RWr offset	R/O	0000H
#57FH	#1407	Station No. 16 RWr size	R/O	0000H
#580H to #5DFH	#1408 to #1503	Use prohibited	-	-

1

Introduction

2

Specification

3

System Configuration

4

Installation

5

Wiring

6

Introduction of Functions

7

Data Link Processing Time

8

Parameter Setting

9

Data Link Procedure

10

Buffer Memory

- Example of when the intelligent device station where expanded cyclic setting has been made are connected
 - When the remote net ver.2 mode is used

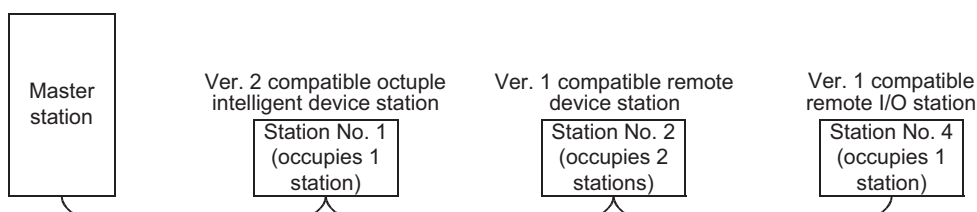

Value of RX/RX/RWw/RWr offset, size

Buffer memory name	Value (Hex.)	Description
Station No. 1 RX offset	4000H	Head buffer memory No. of RX of station No. 1
Station No. 1 RX size	8H	128 (number of RX points) / 16 = 8 words
Station No. 2 RX offset	4008H	Head buffer memory No. of RX of station No. 2
Station No. 2 RX size	4H	The 4 words of buffer memory No. 4008H to 400BH are the corresponding size of RX of station No. 2.
Station No. 3 RX offset	4008H	As 2 stations are occupied, the area of station No. 2 is checked.
Station No. 3 RX size	0H (Initial value)	As 2 stations are occupied, the area of station No. 2 is checked.
Station No. 4 RX offset	400CH	Head buffer memory No. of RX of station No. 4
Station No. 4 RX size	2H	The 2 words of buffer memory No. 400CH to 400DH are the corresponding size of RX of station No. 4.
Station No. 1 RY offset	4200H	Head buffer memory No. of RY of station No. 1
Station No. 1 RY size	8H	128 (number of RY points) / 16 = 8 words
Station No. 2 RY offset	4208H	Head buffer memory No. of RY of station No. 2
Station No. 2 RY size	4H	The 4 words of buffer memory No. 4208H to 420BH are the corresponding size of RY of station No. 2.
Station No. 3 RY offset	4208H	As 2 stations are occupied, the area of station No. 2 is checked.
Station No. 3 RY size	0H (Initial value)	As 2 stations are occupied, the area of station No. 2 is checked.
Station No. 4 RY offset	420CH	Head buffer memory No. of RY of station No. 4
Station No. 4 RY size	2H	The 2 words of buffer memory No. 420CH to 420DH are the corresponding size of RY of station No. 4.
Station No. 1 RWw offset	4400H	Head buffer memory No. of RWw of station No. 1
Station No. 1 RWw size	20H	1 (number of occupied stations) × 4 words × 8 = 32
Station No. 2 RWw offset	4420H	Head buffer memory No. of RWw of station No. 2
Station No. 2 RWw size	8H	2 (number of occupied stations) × 4 words = 8 Buffer memory size No. of RWw of station No. 2
Station No. 3 RWw offset	4420H	As 2 stations are occupied, the area of station No. 2 is checked.
Station No. 3 RWw size	0H (Initial value)	As 2 stations are occupied, the area of station No. 2 is checked.
Station No. 4 RWw offset	4428H	Head buffer memory No. of RWw of station No. 4
Station No. 4 RWw size	0H (Initial value)	Buffer memory size of RWw of station No. 4
Station No. 1 RWr offset	4C00H	Head buffer memory No. of RWr of station No. 1
Station No. 1 RWr size	20H	1 (number of occupied stations) × 4 words × 8 = 32
Station No. 2 RWr offset	4C20H	Head buffer memory No. of RWr of station No. 2
Station No. 2 RWr size	0H (Initial value)	2 (number of occupied stations) × 4 words = 8 Buffer memory size No. of RWr of station No. 2
Station No. 3 RWr offset	4C00H	As 2 stations are occupied, the area of station No. 2 is checked.
Station No. 3 RWr size	0H (Initial value)	As 2 stations are occupied, the area of station No. 2 is checked.
Station No. 4 RWr offset	4C28H	Head buffer memory No. of RWr of station No. 4
Station No. 4 RWr size	0H (Initial value)	Buffer memory size of RWr of station No. 4

- When the remote net additional mode is used

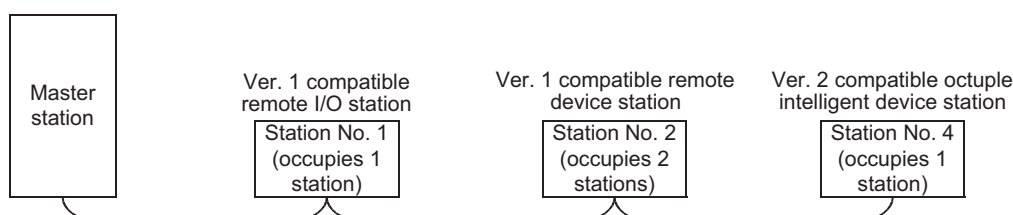

Value of RX/RX/RWw/RWr offset, size

Buffer memory name	Value (Hex.)	Description
Station No. 1 RX offset	E0H	Head buffer memory No. of RX of station No. 1
Station No. 1 RX size	2H	32 (number of RX points) / 16 = 2 words
Station No. 2 RX offset	E2H	Head buffer memory No. of RX of station No. 2
Station No. 2 RX size	4H	The 4 words of the buffer memory No. E2H to E5H are the corresponding size of RX of station No. 2.
Station No. 3 RX offset	E2H	As 2 stations are occupied, the area of station No. 2 is checked.
Station No. 3 RX size	0H (Initial value)	As 2 stations are occupied, the area of station No. 2 is checked.
Station No. 4 RX offset	4006H	Head buffer memory No. of RX of station No. 4
Station No. 4 RX size	8H	The 8 words of the buffer memory No. 4006H to 400DH are the corresponding size of RX of station No. 4.
Station No. 1 RY offset	160H	Head buffer memory No. of RY of station No. 1
Station No. 1 RY size	2H	32 (number of RY points) / 16 = 2 words
Station No. 2 RY offset	162H	Head buffer memory No. of RY of station No. 2
Station No. 2 RY size	4H	The 4 words of the buffer memory No. 162H to 165H are the corresponding size of RY of station No. 2.
Station No. 3 RY offset	162H	As 2 stations are occupied, the area of station No. 2 is checked.
Station No. 3 RY size	0H (Initial value)	As 2 stations are occupied, the area of station No. 2 is checked.
Station No. 4 RY offset	4206H	Head buffer memory No. of RY of station No. 4
Station No. 4 RY size	8H	The 8 words of the buffer memory No. 4206H to 420DH are the corresponding size of RY of station No. 4.
Station No. 1 RWw offset	1E0H	Head buffer memory No. of RWw of station No. 1
Station No. 1 RWw size	4H	1 (number of occupied stations) × 4 words = 4 (A remote I/O station also occupies this area.)
Station No. 2 RWw offset	1E4H	Head buffer memory No. of RWw of station No. 2
Station No. 2 RWw size	8H	2 (number of occupied stations) × 4 words = 8 Buffer memory size No. of RWw of station No. 2
Station No. 3 RWw offset	1E4H	As 2 stations are occupied, the area of station No. 2 is checked.
Station No. 3 RWw size	0H (Initial value)	As 2 stations are occupied, the area of station No. 2 is checked.
Station No. 4 RWw offset	440CH	Head buffer memory No. of RWw of station No. 4
Station No. 4 RWw size	20H	1 (number of occupied stations) × 4 words × 8 = 32
Station No. 1 RWr offset	2E0H	Head buffer memory No. of RWr of station No. 1
Station No. 1 RWr size	4H	1 (number of occupied stations) × 4 words = 4 (A remote I/O station also occupies this area.)
Station No. 2 RWr offset	2E4H	Head buffer memory No. of RWr of station No. 2
Station No. 2 RWr size	8H	2 (number of occupied stations) × 4 words = 8 Buffer memory size No. of RWr of station No. 2
Station No. 3 RWr offset	2E4H	As 2 stations are occupied, the area of station No. 2 is checked.
Station No. 3 RWr size	0H (Initial value)	As 2 stations are occupied, the area of station No. 2 is checked.
Station No. 4 RWr offset	4C0CH	Head buffer memory No. of RWr of station No. 4
Station No. 4 RWr size	20H	1 (number of occupied stations) × 4 words × 8 = 32

1

Introduction

2

Specification

3

System
Configuration

4

Installation

5

Wiring

6

Introduction of
Functions

7

Data Link
Processing
Time

8

Parameter
Setting

9

Data Link
Procedure

10

Buffer Memory

10.12 Link special relay/Link special register (SB/SW)

10.12.1 [BFM#1504 to #1535] Link special relay (SB)

The data link status can be checked using these buffer memory addresses for bit information (link special relays SB).

The table below shows details for the link special relays (SB).

SB No.	BFM No.			Name	Description	Applicability (✓ : Applicable, - : Not applicable)		R/W
	Hex.	Dec.	Bit			Online	Offline	
SB0000	5E0H	1504	b0	Data link restart	Restarts the data link which was stopped by SB0002. OFF: Does not give restart specification ON : Gives restart specification	✓	-	R/W
SB0002	5E0H	1504	b2	Data link stop	Stops the data link in the master station. If the master station sets this relay to ON, the entire system stops. OFF: Does not give stop specification ON : Gives stop specification	✓	-	R/W
SB0004	5E0H	1504	b4	Request for temporary error invalid station	Determines stations specified by SW0003 or SW0004 as temporary error invalid stations. OFF: Does not give the request ON : Gives the request	✓	-	R/W
SB0005	5E0H	1504	b5	Request for cancel of temporary error invalid station	Cancel the stations specified by SW0003 or SW0004 from temporary error invalid stations. OFF: Does not give the request ON : Gives the request	✓	-	R/W
SB0008	5E0H	1504	b8	Request for line test	Executes the line test to the stations specified by SW0008. OFF: Does not give the request ON : Gives the request	✓	-	R/W
SB0009	5E0H	1504	b9	Parameter information read request	Reads the parameter setting information for the actual system configuration. (enabled only on ver. 1 compatible slave stations) OFF: Does not give the request ON : Gives the request	✓	-	R/W
SB000B	5E0H	1504	b11	Transmission speed test request	Use this to perform the transmission speed test. OFF: Does not give the request ON : Gives the request	✓	-	R/W
SB000D	5E0H	1504	b13	Remote device station initialization procedure registration instruction	Starts the initial processing using the information registered during the initialization procedure registration. While SB000D is on, the refresh of the remote input/output and remote registers stops. OFF: Not instructed ON : Instructed	✓	-	R/W
SB0020	5E2H	1506	b0	Unit status	Indicates the unit access (unit operation) status. OFF: Normal (Unit is operating normally) ON : Abnormal (unit error has occurred)	✓	-	R/O
SB0040	5E4H	1508	b0	Data link restart acceptance status	Indicates the data link restart specification acceptance status. OFF: Not accepted ON : Accepted	✓	-	R/O
SB0041	5E4H	1508	b1	Data link restart completion status	Indicates the data link restart specification acceptance completion status. OFF: Not completed ON : Completed	✓	-	R/O
SB0044	5E4H	1508	b4	Data link stop acceptance	Indicates the data link stop specification acceptance status. OFF: Not accepted ON : Accepted	✓	-	R/O
SB0045	5E4H	1508	b5	Data link stop complete	Indicates the data link stop specification acceptance completion status. OFF: Not completed ON : Completed	✓	-	R/O
SB0048	5E4H	1508	b8	Temporary error invalid station acceptance status	Indicates the temporary error invalid station request acceptance status. OFF: Not accepted ON : Accepted	✓	-	R/O

SB No.	BFM No.			Name	Description	Applicability (✓ : Applicable, - : Not applicable)		R/W
	Hex.	Dec.	Bit			Online	Offline	
SB0049	5E4H	1508	b9	Temporary error invalid station completion status	Indicates the temporary error invalid station request acceptance completion status. OFF: Not completed ON : Temporary error invalid stations are determined/ Specified station number is invalid	✓	-	R/O
SB004A	5E4H	1508	b10	Temporary error invalid station completion status	Indicates the temporary error invalid station cancel request acceptance status. OFF: Not accepted ON : Accepted	✓	-	R/O
SB004B	5E4H	1508	b11	Temporary error invalid station cancel acceptance status	Indicates the temporary error invalid station cancel request acceptance completion status. OFF: Not completed ON : Cancel of temporary error invalid stations is completed	✓	-	R/O
SB004C	5E4H	1508	b12	Line test acceptance status	Indicates the line test request acceptance status. OFF: Not accepted ON : Accepted	✓	-	R/O
SB004D	5E4H	1508	b13	Line test completion status	Indicates the line test completion status. OFF: Not completed ON : Completed	✓	-	R/O
SB004E	5E4H	1508	b14	Parameter verification test acceptance status	Indicates the parameter verification test request acceptance status. OFF: Not accepted ON : Accepted	✓	-	R/O
SB004F	5E4H	1508	b15	Parameter verification test completion status	Indicates the parameter verification test completion status. OFF: Not completed ON : Completed	✓	-	R/O
SB0050	5E5H	1509	b0	Offline test execution status	Indicates the offline test execution status. OFF: Not executed ON : Being executed	-	✓	R/O
SB005E	5E5H	1509	b14	Execution status of remote device station initialization procedure	Indicates the execution status of the initialization procedure. OFF: Not executed ON : Being executed	✓	-	R/O
SB005F	5E5H	1509	b15	Completion status of remote device station initialization procedure	Indicates the completion status of the initialization procedure execution. OFF: Not completed ON : Completed	✓	-	R/O
SB0060	5E6H	1510	b0	Master station mode	Indicates the setting status of the Transmission rate setting switch in the master block. OFF: Online ON : Other than online	✓	✓	R/O
SB0061	5E6H	1510	b1	Master station type	Indicates the setting status of the station number setting switch in the master block. OFF: Master station ON : Setting error (The station number is not set to 0.)	✓	-	R/O
SB0065	5E6H	1510	b5	Input data status of master data link faulty station	Indicates the input status setting from a data link faulty station of the master block. OFF: Clear ON : Keep	✓	-	R/O
SB006A	5E6H	1510	b10	Switch setting status	Indicates the switch setting status. OFF: Normal ON : Setting error (The error code is stored in SW006A.)	✓	✓	R/O
SB006D	5E6H	1510	b13	Parameter setting status	Indicates the parameter setting status. OFF: Normal ON : Setting error (The error code is stored in SW0068.)	✓	-	R/O
SB006E	5E6H	1510	b14	Operation status in master station	Indicates the data link communication status with other stations. OFF: Being executed ON : Not executed	✓	-	R/O
SB0070	5E7H	1511	b0	Master station information	Indicates the data link status. OFF: Data link control by the master station ON : Data link control by the standby master station	✓	-	R/O

1

Introduction

2

Specification

3

System Configuration

4

Installation

5

Wiring

6

Introduction of Functions

7

Data Link Processing Time

8

Parameter Setting

9

Data Link Procedure

10

Buffer Memory

SB No.	BFM No.			Name	Description	Applicability (✓ : Applicable, - : Not applicable)		R/W
	Hex.	Dec.	Bit			Online	Offline	
SB0073	5E7H	1511	b3	Status of operation specification against CPU down	Indicates the status of operation specification against CPU down by parameter. OFF: Stop ON : Continue	✓	-	R/O
SB0074	5E7H	1511	b4	Reserved station specification status	Indicates the reserved station specification status by parameter. OFF: Not specified ON : Specified (The error code is stored in SW0074.)	✓	-	R/O
SB0075	5E7H	1511	b5	Error invalid station specification status	Indicates the error invalid station specification status by parameter. OFF: Not specified ON : Specified (The error code is stored in SW0078.)	✓	-	R/O
SB0076	5E7H	1511	b6	Temporary error invalid station specification status	Indicates the temporary error invalid station specification status. OFF: Not specified ON : Specified (The error code is stored in SW007C.)	✓	-	R/O
SB0078	5E7H	1511	b8	Switch change status in master station	Detects change in the setting switches in the master station during data link. OFF: No change ON : Change	✓	-	R/O
SB007C	5E7H	1511	b12	Slave station refresh/compulsory clear setting status in case of programmable controller CPU STOP	Indicates the parameter-set slave station refresh/compulsory clear setting status in case of programmable controller CPU STOP. OFF: Refresh ON : Clears compulsorily	✓	-	R/O
SB0080	5E8H	1512	b0	Data link status in other stations*1	Indicates the data link status with remote stations and intelligent device stations. OFF: All stations are normal ON : Some stations are faulty (The error code is stored in SW0080.)	✓	-	R/O
SB0081	5E8H	1512	b1	Watchdog timer error status in other stations	Indicates the watchdog timer error occurrence status in other stations. OFF: No error ON : Error (The error code is stored in SW0084.)	✓	-	R/O
SB0082	5E8H	1512	b2	Fuse blowout status in other stations	Indicates the fuse blowout occurrence status in other stations. OFF: No error ON : Error (The error code is stored in SW0088.)	✓	-	R/O
SB0083	5E8H	1512	b3	Switch change status in other stations	Detects change in the setting switches in other stations during data link. OFF: No change ON : Change (The error code is stored in SW008C.)	✓	-	R/O
SB0094	5E9H	1513	b4	Other stations transient transmission status	Indicates whether a transient transmission error has occurred in other stations OFF: No error ON : Error (The error code is stored in SW0094.)	✓	-	R/O
SB0185	5F8H	1528	b5	Transmission speed test accept status	Indicates the accept status of Transmission speed test request. OFF: Not accepted ON : Accepted	✓	-	R/O
SB0186	5F8H	1528	b6	Transmission speed test completion status	Indicates the completion status of the transmission speed test. OFF: Not completed ON : Test complete	✓	-	R/O

*1. The other station data link status takes up to 6 seconds to turn on after a slave station connected to the master station becomes faulty. The time to turn ON differs according to the system configuration, faulty status or other conditions.

10.12.2 [BFM#1536 to #2047] Link special register (SW)

The operator can check the data link status using these buffer memory addresses for word information (link special registers SW).

The table below shows details of link special registers (SW).

→ For the updating timing of a link special register, refer to Subsection 11.2.3.

SW No.	BFM No.		Name	Description	Applicability (✓ : Applicable, - : Not applicable)		R/W																		
	Hex.	Dec.			Online	Offline																			
SW0003	603H	1539	Specification of multiple temporary error invalid stations	Selects whether or not to specify two or more temporary error invalid stations. 00: Specifies two or more stations stored in SW0004 1 to 16: Specifies a single station whose station number is 1 to 16 (The number indicates the station number of a temporary error invalid station.)	✓	-	R/W																		
SW0004	604H	1540	Temporary error invalid station specification	Specifies temporary error invalid stations. 0: Does not specify as temporary error invalid station 1: Specifies as temporary error invalid station <table style="margin-left: 20px;"> <tr> <td>b15</td><td>b14</td><td>b13</td><td>b12</td><td>to</td><td>b3</td><td>b2</td><td>b1</td><td>b0</td> </tr> <tr> <td>16</td><td>15</td><td>14</td><td>13</td><td>to</td><td>4</td><td>3</td><td>2</td><td>1</td> </tr> </table> Numbers 1 to 16 above indicate station numbers. (Only the bit corresponding to the head station number is set to ON.) Error invalid stations, reserved stations and any station of the number higher than the max. are not specified.	b15	b14	b13	b12	to	b3	b2	b1	b0	16	15	14	13	to	4	3	2	1	✓	-	R/W
b15	b14	b13	b12	to	b3	b2	b1	b0																	
16	15	14	13	to	4	3	2	1																	
SW0008	608H	1544	Line test station setting	Sets the stations to be subject to the line test. 0: Entire system (The line test will be executed to all stations.) 1 to 16: Specifies a single station whose station number is 1 to 16 Initial value: 0	✓	-	R/W																		
SW0014	614H	1556	Specification of remote device station to be initialized	Specifies the station to be initialized using the information saved in initialization procedure registration. 0: Initial processing not performed 1: Initial processing performed <table style="margin-left: 20px;"> <tr> <td>b15</td><td>b14</td><td>b13</td><td>b12</td><td>to</td><td>b3</td><td>b2</td><td>b1</td><td>b0</td> </tr> <tr> <td>16</td><td>15</td><td>14</td><td>13</td><td>to</td><td>4</td><td>3</td><td>2</td><td>1</td> </tr> </table> Numbers 1 to 16 above indicate station numbers. (Only the bit corresponding to the head station number is set to ON.) Error invalid stations, reserved stations and any station of the number higher than the max. are not specified.	b15	b14	b13	b12	to	b3	b2	b1	b0	16	15	14	13	to	4	3	2	1	✓	-	R/W
b15	b14	b13	b12	to	b3	b2	b1	b0																	
16	15	14	13	to	4	3	2	1																	
SW0041	641H	1601	Result of data link restart	Stores the execution result of data link restart specification by SB0000. 0: Normal Other than 0: Stores the error code (Refer to Section 16.3.).	✓	-	R/O																		
SW0045	645H	1605	Result of data link stop	Stores the execution result of data link stop specification by SB0002. 0: Normal Other than 0: Stores the error code (Refer to Section 16.3.).	✓	-	R/O																		
SW0049	649H	1609	Result of request for temporary error invalid stations	Stores the execution result of request for temporary error invalid stations by SB0004. 0: Normal Other than 0: Stores the error code (Refer to Section 16.3.).	✓	-	R/O																		
SW004B	64BH	1611	Result of request for cancel of temporary error invalid stations	Stores the execution result of request for cancel of temporary error invalid stations by SB0005. 0: Normal Other than 0: Stores the error code (Refer to Section 16.3.).	✓	-	R/O																		
SW004D	64DH	1613	Line test result	Stores the execution result of request for line test by SB0008. 0: Normal Other than 0: Stores the error code (Refer to Section 16.3.).	✓	-	R/O																		
SW004F	64FH	1615	Result of request for parameter verification test	Indicates the execution result of request for parameter verification test by SB0009. 0: Normal Other than 0: Stores the error code (Refer to Section 16.3.).	✓	-	R/O																		

1

Introduction

2

Specification

3

System Configuration

4

Installation

5

Wiring

6

Introduction of Functions

7

Data Link Processing Time

8

Parameter Setting

9

Data Link Procedure

10

Buffer Memory

SW No.	BFM No.		Name	Description	Applicability (✓ : Applicable, - : Not applicable)		R/W																																	
	Hex.	Dec.			Online	Offline																																		
SW0058	658H	1624	Detailed LED display status	<p>Stores the details of the LED display status. 0: OFF 1: ON</p> <table border="1"><tr><td>b15</td><td>b14</td><td>b13</td><td>b12</td><td>b11</td><td>b10</td><td>b9</td><td>b8</td><td>b7</td><td>b6</td><td>b5</td><td>b4</td><td>b3</td><td>b2</td><td>b1</td><td>b0</td></tr><tr><td></td><td></td><td></td><td></td><td></td><td></td><td></td><td>0</td><td>0</td><td></td><td></td><td></td><td></td><td>0</td><td>0</td><td>0</td><td>0</td></tr></table> <p>→ LINE(ERR.): Cable is disconnected or the transmission path is affected by noise. → TIME(ERR.): Responses cannot be received from any of the stations due to cable disconnection or noise affecting the transmission path. → PRM(ERR.): Invalid parameter value. → M/S(ERR.): Duplicate master station on the same line. → SW(ERR.): Error in switch settings. → MST(ERR.): Operating as the master station. → ERR.: Error occurrence. → RUN: The module is operating normally.</p>	b15	b14	b13	b12	b11	b10	b9	b8	b7	b6	b5	b4	b3	b2	b1	b0								0	0					0	0	0	0	✓	✓	R/O
b15	b14	b13	b12	b11	b10	b9	b8	b7	b6	b5	b4	b3	b2	b1	b0																									
							0	0					0	0	0	0																								
SW0059	659H	1625	Transmission rate setting	<p>Stores the contents of the transmission rate setting. 0: Cancel 1: Set</p> <table border="1"><tr><td>b15</td><td>b8</td><td>b7</td><td>b6</td><td>b5</td><td>b4</td><td>b3</td><td>b2</td><td>b1</td><td>b0</td></tr><tr><td>0</td><td>to</td><td>0</td><td></td><td></td><td></td><td></td><td>0</td><td>0</td><td>0</td></tr></table> <p>→ 10 Mbps → 5 Mbps → 2.5 Mbps → 625 kbps → 156 kbps</p> <p>Stores the information that be comes valid when the FX3U-16CCL-M is started. (Changes to the rotary switch are not reflected after the FX3U-16CCL-M is started.)</p>	b15	b8	b7	b6	b5	b4	b3	b2	b1	b0	0	to	0					0	0	0	✓	✓	R/O													
b15	b8	b7	b6	b5	b4	b3	b2	b1	b0																															
0	to	0					0	0	0																															
SW005F	65FH	1631	Remote device station initialization procedure registration instruction result	<p>Stores the execution result of the initialization procedure registration instruction with SB000D. 0: Normal Other than 0: Stores the error code (Refer to Section 16.3.).</p>	✓	-	R/O																																	
SW0060	660H	1632	Mode setting status	<p>Stores the mode setting status. 0: Online 1: Offline 3: Line test 1 4: Line test 2 6: Hardware test</p> <p>Stores the information that be comes valid when the FX3U-16CCL-M is started. (Changes to the rotary switch are not reflected after the FX3U-16CCL-M is started.)</p>	✓	✓	R/O																																	

SW No.	BFM No.		Name	Description	Applicability (✓ : Applicable, - : Not applicable)		R/W													
	Hex.	Dec.			Online	Offline														
SW0061	661H	1633	Master station number	Stores the station number of the master that is currently in operation. 0: Master station Other than 0: Errors in the setting Stores the information that becomes valid when the FX3U-16CCL-M is started. (Changes to the rotary switch are not reflected after the FX3U-16CCL-M is started.)	✓	✓	R/O													
SW0064	664H	1636	Number of retries setting	Stores the setting status of the number of retries against response error. 1 to 7 (times)	✓	-	R/O													
SW0065	665H	1637	Number of automatic return stations setting	Stores the setting status of the number of automatic return modules during one link scan. 1 to 10 (units)	✓	-	R/O													
SW0067	667H	1639	Parameter information	Stores the parameter information area to be used. 0: Network parameter 1: Buffer memory	✓	✓	R/O													
SW0068	668H	1640	Parameter status in master station	Stores the parameter setting status. 0: Normal Other than 0: Stores the error code (Refer to Section 16.3.).	✓	-	R/O													
SW0069	669H	1641	Loading status	Stores station number overlap and consistency with parameters in each unit. (The loading status is checked only when link starts up, then stored.) 0: Normal Other than 0: Stores the error code (Refer to Section 16.3.).	✓	-	R/O													
SW006A	66AH	1642	Switch setting status	Stores the switch setting status. 0: Normal Other than 0: Stores the error code (Refer to Section 16.3.).	✓	✓	R/O													
SW006D	66DH	1645	Maximum link scan time	Stores the maximum value of the link scan time. (unit: 1 ms)	✓	-	R/O													
SW006E	66EH	1646	Current link scan time	Stores the current value of the link scan time. (unit: 1 ms)	✓	-	R/O													
SW006F	66FH	1647	Minimum link scan time	Stores the minimum value of the link scan time. (unit: 1 ms)	✓	-	R/O													
SW0070	670H	1648	Total number of stations	Stores the last station number set in parameter. 1 to 16 (stations)	✓	-	R/O													
SW0071	671H	1649	Maximum communication station number	Stores the maximum station number (station number set by the station number setting switch) in the data link. 1 to 16 (stations)	✓	-	R/O													
SW0072	672H	1650	Number of connected units	Stores the number of modules (except reserved stations) in the data link. 1 to 16 (stations)	✓	-	R/O													
SW0074	674H	1652	Reserved station specification status	Stores the reserved station specification status. 0: Not specified as reserved station Other than 0: Specified as reserved station <div style="display: flex; align-items: center; gap: 10px;"> SW0074 <table border="1" style="border-collapse: collapse; text-align: center;"> <tr> <td colspan="4">b15b14b13b12 to b3 b2 b1 b0</td> </tr> <tr> <td>16</td><td>15</td><td>14</td><td>13</td> <td>to</td> <td>4</td><td>3</td><td>2</td><td>1</td> </tr> </table> </div> Numbers 1 to 16 above indicate station numbers. (Only the bit corresponding to the head station number is set to ON.) Any station of the number higher than the max. are excepted.	b15b14b13b12 to b3 b2 b1 b0				16	15	14	13	to	4	3	2	1	✓	-	R/O
b15b14b13b12 to b3 b2 b1 b0																				
16	15	14	13	to	4	3	2	1												
SW0078	678H	1656	Error invalid station specification status	Stores the error invalid station specification status. 0: Not specified as error invalid station 1: Specified as error invalid station <div style="display: flex; align-items: center; gap: 10px;"> SW0078 <table border="1" style="border-collapse: collapse; text-align: center;"> <tr> <td colspan="4">b15b14b13b12 to b3 b2 b1 b0</td> </tr> <tr> <td>16</td><td>15</td><td>14</td><td>13</td> <td>to</td> <td>4</td><td>3</td><td>2</td><td>1</td> </tr> </table> </div> Numbers 1 to 16 above indicate station numbers. (Only the bit corresponding to the head station number is set to ON.) Reserved stations and any station of the number higher than the max. are excepted.	b15b14b13b12 to b3 b2 b1 b0				16	15	14	13	to	4	3	2	1	✓	-	R/O
b15b14b13b12 to b3 b2 b1 b0																				
16	15	14	13	to	4	3	2	1												

1

Introduction

2

Specification

3

System Configuration

4

Installation

5

Wiring

6

Introduction of Functions

7

Data Link Processing Time

8

Parameter Setting

9

Data Link Procedure

10

Buffer Memory

SW No.	BFM No.		Name	Description	Applicability (✓ : Applicable, - : Not applicable)		R/W									
	Hex.	Dec.			Online	Offline										
SW007C	67CH	1660	Temporary error invalid station specification status	<p>Stores the temporary error invalid station specification status.</p> <p>0: Normal status 1: Temporary error invalid status</p> <p style="text-align: center;">b15b14b13b12 to b3 b2 b1 b0</p> <p>SW007C <table border="1" style="display: inline-table;"><tr><td>16</td><td>15</td><td>14</td><td>13</td><td>to</td><td>4</td><td>3</td><td>2</td><td>1</td></tr></table></p> <p>Numbers 1 to 16 above indicate station numbers. (Bits corresponding to as many as the number of occupied stations are set to ON.)</p> <p>Error invalid stations, reserved stations and any station of the number higher than the max. are excepted.</p>	16	15	14	13	to	4	3	2	1	✓	-	R/O
16	15	14	13	to	4	3	2	1								
SW0080	680H	1664	Data link status in other stations	<p>Stores the data link status in each station.</p> <p>0: Normal 1: Data link error</p> <p style="text-align: center;">b15b14b13b12 to b3 b2 b1 b0</p> <p>SW0080 <table border="1" style="display: inline-table;"><tr><td>16</td><td>15</td><td>14</td><td>13</td><td>to</td><td>4</td><td>3</td><td>2</td><td>1</td></tr></table></p> <p>Numbers 1 to 16 above indicate station numbers. (Bits corresponding to as many as the number of occupied stations are set to ON.)</p> <p>Temporary error invalid stations, error invalid stations, reserved stations and any station of the number higher than the max. are excepted.</p>	16	15	14	13	to	4	3	2	1	✓	-	R/O
16	15	14	13	to	4	3	2	1								
SW0084	684H	1668	Watchdog timer error occurrence status in other stations	<p>Stores the watchdog timer error occurrence status in each station.</p> <p>0: No watchdog timer error 1: Watchdog timer error occurred</p> <p style="text-align: center;">b15b14b13b12 to b3 b2 b1 b0</p> <p>SW0084 <table border="1" style="display: inline-table;"><tr><td>16</td><td>15</td><td>14</td><td>13</td><td>to</td><td>4</td><td>3</td><td>2</td><td>1</td></tr></table></p> <p>Numbers 1 to 16 above indicate station numbers. (Only the bit corresponding to the head station number is set to ON.)</p> <p>Reserved stations and any station of the number higher than the max. are excepted.</p>	16	15	14	13	to	4	3	2	1	✓	-	R/O
16	15	14	13	to	4	3	2	1								
SW0088	688H	1672	Fuse blowout status in other stations	<p>Stores the fuse blowout status in each station.</p> <p>0: Normal 1: Fuse blowout error</p> <p style="text-align: center;">b15b14b13b12 to b3 b2 b1 b0</p> <p>SW0088 <table border="1" style="display: inline-table;"><tr><td>16</td><td>15</td><td>14</td><td>13</td><td>to</td><td>4</td><td>3</td><td>2</td><td>1</td></tr></table></p> <p>Numbers 1 to 16 above indicate station numbers. (Bits corresponding to as many as the number of occupied stations are set to ON.)</p> <p>Reserved stations and any station of the number higher than the max. are excepted.</p>	16	15	14	13	to	4	3	2	1	✓	-	R/O
16	15	14	13	to	4	3	2	1								
SW008C	68CH	1676	Switch change status in other stations	<p>Stores the switch change status in other stations during data link.</p> <p>0: No change 1: Change</p> <p style="text-align: center;">b15b14b13b12 to b3 b2 b1 b0</p> <p>SW008C <table border="1" style="display: inline-table;"><tr><td>16</td><td>15</td><td>14</td><td>13</td><td>to</td><td>4</td><td>3</td><td>2</td><td>1</td></tr></table></p> <p>Numbers 1 to 16 above indicate station numbers. (Only the bit corresponding to the head station number is set to ON.)</p> <p>Reserved stations and any station of the number higher than the max. are excepted.</p>	16	15	14	13	to	4	3	2	1	✓	-	R/O
16	15	14	13	to	4	3	2	1								

SW No.	BFM No.		Name	Description	Applicability (✓ : Applicable, - : Not applicable)		R/W																
	Hex.	Dec.			Online	Offline																	
SW0098	698H	1688	Station number overlap status	<p>Stores the overlap status in which the head station number of each unit does not overlap. (The status is checked and stored only at link startup and at parameter update.) 0: Normal 1: Station number overlap (only the head station number)</p> <p>b15b14b13b12 to b3 b2 b1 b0 SW0098 <table border="1" style="display: inline-table;"><tr><td>16</td><td>15</td><td>14</td><td>13</td><td>to</td><td>4</td><td>3</td><td>2</td><td>1</td></tr></table></p> <p>Numbers 1 to 16 above indicate station numbers. (Only the bit corresponding to the head station number is set to ON.) Reserved stations and any station of the number higher than the max. are excepted.</p>	16	15	14	13	to	4	3	2	1	✓	-	R/O							
16	15	14	13	to	4	3	2	1															
SW009C	69CH	1692	Loading/parameter consistency status	<p>Stores the consistency with parameters. (The status is checked and stored only at link startup and at parameter update.) A consistency error occurs in any of the following cases. 1) Station type mismatch* 2) Number of occupied stations mismatch 3) Expanded cyclic setting mismatch* 4) CC-Link compatible version mismatch *A consistency error will not occur when installation ≤ parameter. (For example, a consistency error will not occur when a remote device station is installed and the parameter setting is an intelligent device station.) 0: Normal 1: Consistency error Example of consistency error</p> <table border="1" style="margin-left: auto; margin-right: auto;"> <thead> <tr> <th>Loading</th> <th>Parameter</th> </tr> </thead> <tbody> <tr> <td>Remote device station</td> <td>Remote I/O station</td> </tr> <tr> <td rowspan="2">Intelligent device station</td> <td>Remote I/O station</td> </tr> <tr> <td>Remote device station</td> </tr> </tbody> </table> <p>b15b14b13b12 to b3 b2 b1 b0 SW009C <table border="1" style="display: inline-table;"><tr><td>16</td><td>15</td><td>14</td><td>13</td><td>to</td><td>4</td><td>3</td><td>2</td><td>1</td></tr></table></p> <p>Numbers 1 to 16 above indicate station numbers. (Only the bit corresponding to the head station number is set to ON.) Reserved stations and any station of the number higher than the max. are excepted.</p>	Loading	Parameter	Remote device station	Remote I/O station	Intelligent device station	Remote I/O station	Remote device station	16	15	14	13	to	4	3	2	1	✓	-	R/O
Loading	Parameter																						
Remote device station	Remote I/O station																						
Intelligent device station	Remote I/O station																						
	Remote device station																						
16	15	14	13	to	4	3	2	1															
SW00B4	6B4H	1716	Line test 1 result	<p>Stores the line test 1 result. 0: Normal 1: Error</p> <p>b15b14b13b12 to b3 b2 b1 b0 SW00B4 <table border="1" style="display: inline-table;"><tr><td>16</td><td>15</td><td>14</td><td>13</td><td>to</td><td>4</td><td>3</td><td>2</td><td>1</td></tr></table></p> <p>Numbers 1 to 16 above indicate station numbers. (Bits corresponding to as many as the number of occupied stations are set to ON.)</p>	16	15	14	13	to	4	3	2	1	✓	✓	R/O							
16	15	14	13	to	4	3	2	1															
SW00B8	6B8H	1720	Line test result	<p>Stores the line test 1/line test 2 result. 0: Normal Other than 0: Stores the error code (Refer to Section 16.3.).</p>	-	✓	R/O																
SW0110 to SW0117	710H to 717H	1808 to 1815	Remote device station initialization procedure registration execution individual information (target 1 to 8)	<p>The execution phase of initialization procedure registration is stored. Upper bit: Next execution procedure number (FFH at completion) Lower bit: Targeted station number</p>	✓	-	R/O																

1

Introduction

2

Specification

3

System Configuration

4

Installation

5

Wiring

6

Introduction of Functions

7

Data Link Processing Time

8

Parameter Setting

9

Data Link Procedure

10

Buffer Memory

SW No.	BFM No.		Name	Description	Applicability (✓ : Applicable, - : Not applicable)		R/W															
	Hex.	Dec.			Online	Offline																
SW0140	740H	1856	Compatible CC-Link ver. information	<p>Indicates the remote stations/intelligent device station compatible with CC-Link ver. 2.</p> <p>0: Ver. 1 compatible remote station/intelligent device station 1: Ver. 2 compatible remote station/intelligent device station</p> <p style="text-align: center;">b15b14b13b12 to b3 b2 b1 b0</p> <p>SW0140 <table border="1" style="display: inline-table;"><tr><td>16</td><td>15</td><td>14</td><td>13</td><td>to</td><td>4</td><td>3</td><td>2</td><td>1</td></tr></table></p> <p>Numbers 1 to 16 above indicate station numbers. (Bits corresponding to as many as the number of occupied stations are set to ON.) Reserved stations and any station of the number higher than the max. are excepted.</p>	16	15	14	13	to	4	3	2	1	✓	-	R/O						
16	15	14	13	to	4	3	2	1														
SW0144	744H	1860	CC-Link ver. loading/parameter consistency status	<p>Stores the CC-Link version matching status of the parameters and remote device stations/intelligent device stations.</p> <p>0: Normal 1: Consistency error</p> <p>Example of consistency error</p> <table border="1" style="width: 100%; border-collapse: collapse;"> <thead> <tr> <th style="width: 50%;">Loading</th> <th style="width: 50%;">Parameter</th> </tr> </thead> <tbody> <tr> <td>Ver. 2 compatible remote device station</td> <td>Ver. 1 compatible remote device station</td> </tr> <tr> <td>Ver. 1 compatible remote device station</td> <td>Ver. 2 compatible remote device station</td> </tr> </tbody> </table> <p style="text-align: center;">b15b14b13b12 to b3 b2 b1 b0</p> <p>SW0144 <table border="1" style="display: inline-table;"><tr><td>16</td><td>15</td><td>14</td><td>13</td><td>to</td><td>4</td><td>3</td><td>2</td><td>1</td></tr></table></p> <p>Numbers 1 to 16 above indicate station numbers. (Bits corresponding to as many as the number of occupied stations are set to ON.) Reserved stations and any station of the number higher than the max. are excepted.</p>	Loading	Parameter	Ver. 2 compatible remote device station	Ver. 1 compatible remote device station	Ver. 1 compatible remote device station	Ver. 2 compatible remote device station	16	15	14	13	to	4	3	2	1	✓	-	R/O
Loading	Parameter																					
Ver. 2 compatible remote device station	Ver. 1 compatible remote device station																					
Ver. 1 compatible remote device station	Ver. 2 compatible remote device station																					
16	15	14	13	to	4	3	2	1														
SW0148	748H	1864	Parameter mode	<p>Indicates in which mode the system is operating.</p> <p>0: Remote net ver. 1 mode 1: Remote net additional mode 2: Remote net ver. 2 mode</p> <p>When all the stations are faulty, parameter mode is 0.</p>	✓	-	R/O															
SW0149	749H	1865	Master parameter mode	<p>Indicates in which mode the master is operating.</p> <p>0: Remote net ver. 1 mode 1: Remote net additional mode 2: Remote net ver. 2 mode</p>	✓	✓	R/O															
SW0183	783H	1923	Transmission speed test result	<p>Indicates the execution result of the transmission speed test.</p> <p>0: Normal Other than 0: Stores the error code (Refer to Section 16.3.).</p>	✓	✓	R/O															
SW0184	784H	1924	Transmission speed test result for each station	<p>Indicates transmission rate speed test results by station numbers.</p> <p>0: Normal (Same transmission speed as that of master station, or no response from the unit.) 1: Abnormal (Different transmission speed from that of master station.)</p> <p style="text-align: center;">b15b14b13b12 to b3 b2 b1 b0</p> <p>SW0184 <table border="1" style="display: inline-table;"><tr><td>16</td><td>15</td><td>14</td><td>13</td><td>to</td><td>4</td><td>3</td><td>2</td><td>1</td></tr></table></p> <p>Numbers 1 to 16 above indicate station numbers. (Only the bit corresponding to the head station number is set to ON.)</p>	16	15	14	13	to	4	3	2	1	✓	✓	R/O						
16	15	14	13	to	4	3	2	1														

10.13 [BFM#16384 to #16415] Ver. 2 Compatible Remote Input (RX)

Used when the remote net ver. 2 mode or remote net additional mode is selected.

The input status from remote I/O stations, remote device stations and intelligent device stations are stored.

When 1 station is occupied, 2, 4 or 8 words are used. The number of used points changes depending on the expanded cyclic setting and the number of occupied stations.

In addition, the ver. 2 compatible remote input (RX) is assigned to the following buffer memories according to slave station offset and size information (RX offset, RX size).

→ For details on the expanded cyclic setting and number of occupied stations, refer to Section 2.3.

→ For details on the slave station offset and size information, refer to Section 10.11.

BFM No.		Item	Description	R/W
Hex.	Dec.			
#4000H to #401FH	#16384 to #16415	Ver. 2 compatible remote input (RX)	Stores the input status from a remote station and intelligent device station.	R/O

Example

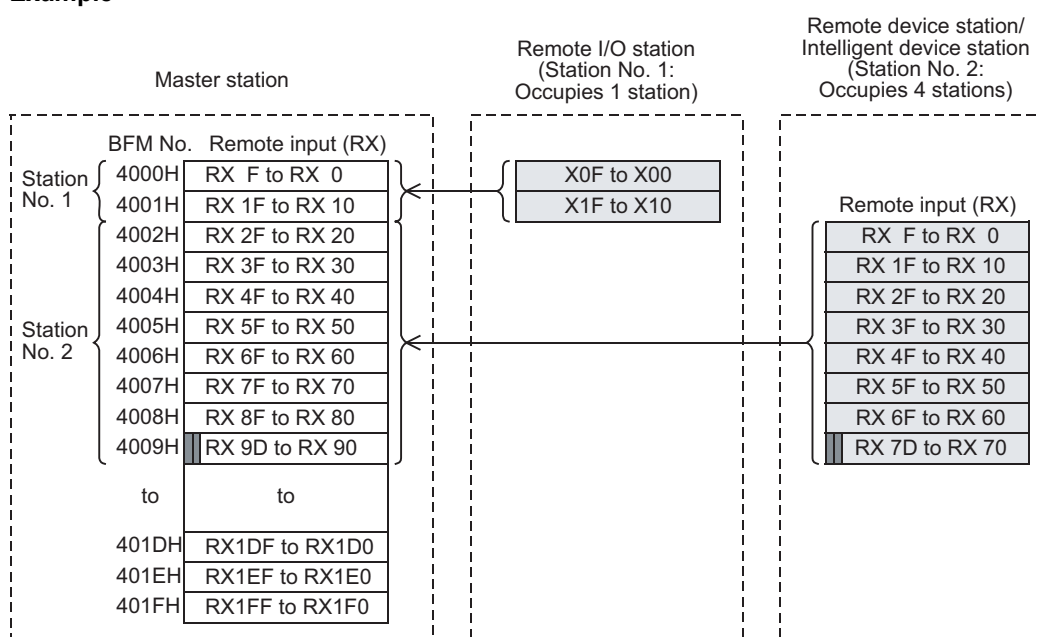

▬ : The last two bits cannot be used in the communication between the master and intelligent device stations.
(In the example above, RX9E and RX9F cannot be used.)

Caution

- When the TO instruction (or direct buffer memory specification) is executed, writing is invalid. When the FROM instruction (or direct buffer memory specification) is executed for reading from an area without assigned link points, the reading operation results in "0" being read.
- The last two bits cannot be used in the communication between the master and intelligent device stations.
- The upper 16bits (1 word) in the last station of remote stations and intelligent device stations is occupied as a system area. For details, refer to the each unit's manuals.

1

Introduction

2

Specification

3

System Configuration

4

Installation

5

Wiring

6

Introduction of Functions

7

Data Link Processing Time

8

Parameter Setting

9

Data Link Procedure

10

Buffer Memory

10.14 [BFM#16896 to #16927] Ver. 2 Compatible Remote Output (RY)

Used when the remote net ver. 2 mode or remote net additional mode is selected.

The output status from remote I/O stations, remote device stations and intelligent device stations are stored. When 1 station is occupied, 2, 4 or 8 words are used. The number of used points changes depending on the expanded cyclic setting and the number of occupied stations.

In addition, the ver. 2 compatible remote output (RY) is assigned to the following buffer memories according to slave station offset and size information (RY offset, RY size).

→ For details on the expanded cyclic setting and number of occupied stations, refer to Section 2.3.

→ For details on the slave station offset and size information, refer to Section 10.11.

BFM No.		Item	Description	R/W
Hex.	Dec.			
#4200H to #421FH	#16896 to #16927	Ver. 2 compatible remote output (RY)	Stores the output status to a remote station and intelligent device station.	R/W

Example

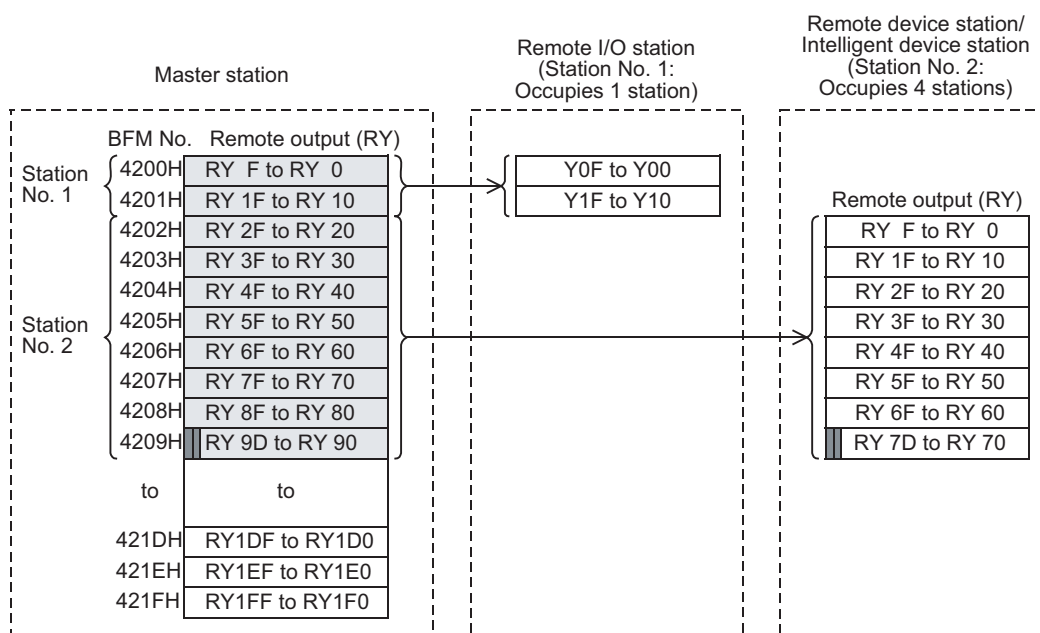

▬ : The last two bits cannot be used in the communication between the master and intelligent device stations. (In the example above, RY9E and RY9F cannot be used.)

Caution

- When the TO instruction (or direct buffer memory specification) is executed for writing to an area without assigned link points, writing is invalid. When the FROM instruction (or direct buffer memory specification) is executed for reading from an area without assigned link points, the reading operation results in "0" being read.
- The last two bits cannot be used in the communication between the master and intelligent device stations.
- The upper 16bits (1 word) in the last station of remote stations and intelligent device stations is occupied as a system area. For details, refer to the each unit's manuals.

10.15 [BFM#17408 to #17503] Ver. 2 Compatible Remote Registers (RWw)

Used when the remote net ver. 2 mode or remote net additional mode is selected.

The data transmitted to the remote register (RWw) in remote device stations and intelligent device stations is stored as below.

When 1 station is occupied, 4 to 32 words are used. The number of used points changes depending on the expanded cyclic setting and the number of occupied stations.

In addition, the ver. 2 compatible remote registers (RWw) is assigned to the following buffer memories according to slave station offset and size information (RWw offset, RWw size).

→ For details on the expanded cyclic setting and number of occupied stations, refer to Section 2.3.

→ For details on the slave station offset and size information, refer to Section 10.11.

BFM No.		Item	Description	R/W
Hex.	Dec.			
#4400H to #445FH	#17408 to #17503	Ver. 2 compatible remote registers (RWw)	Stores the transmission data to a remote station and intelligent device station.	R/W

Example

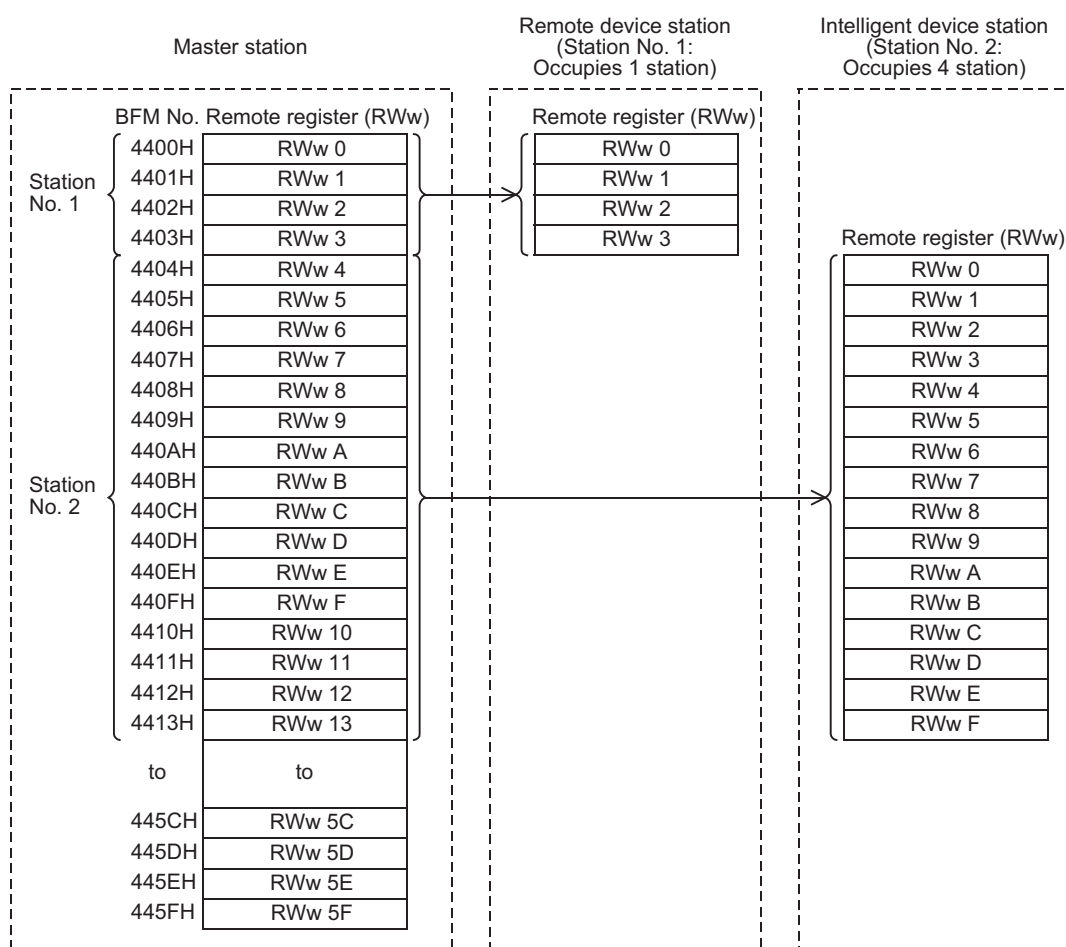

Caution

- When the TO instruction (or direct buffer memory specification) is executed for writing to an area without assigned link points, writing is invalid.
When the FROM instruction (or direct buffer memory specification) is executed for reading from an area without assigned link points, the reading operation results in "0" being read.

1

Introduction

2

Specification

3

System Configuration

4

Installation

5

Wiring

6

Introduction of Functions

7

Data Link Processing Time

8

Parameter Setting

9

Data Link Procedure

10

Buffer Memory

10.16 [BFM#19456 to #19551] Ver. 2 Compatible Remote Registers (RWr)

Used when the remote net ver. 2 mode or remote net additional mode is selected.

The data transmitted from the remote register (RWr) in remote device stations and intelligent device stations is stored as below.

When 1 station is occupied, 4 to 32 words are used. The number of used points changes depending on the expanded cyclic setting and the number of occupied stations.

In addition, the ver. 2 compatible remote registers (RWr) is assigned to the following buffer memories according to slave station offset and size information (RWr offset, RWr size).

→ For details on the expanded cyclic setting and number of occupied stations, refer to Section 2.3.

→ For details on the slave station offset and size information, refer to Section 10.11.

BFM No.		Item	Description	R/W
Hex.	Dec.			
#4C00H to #4C5FH	#19456 to #19551	Ver. 2 compatible remote registers (RWr)	Stores the received data from a remote station and intelligent device station.	R/O

Example

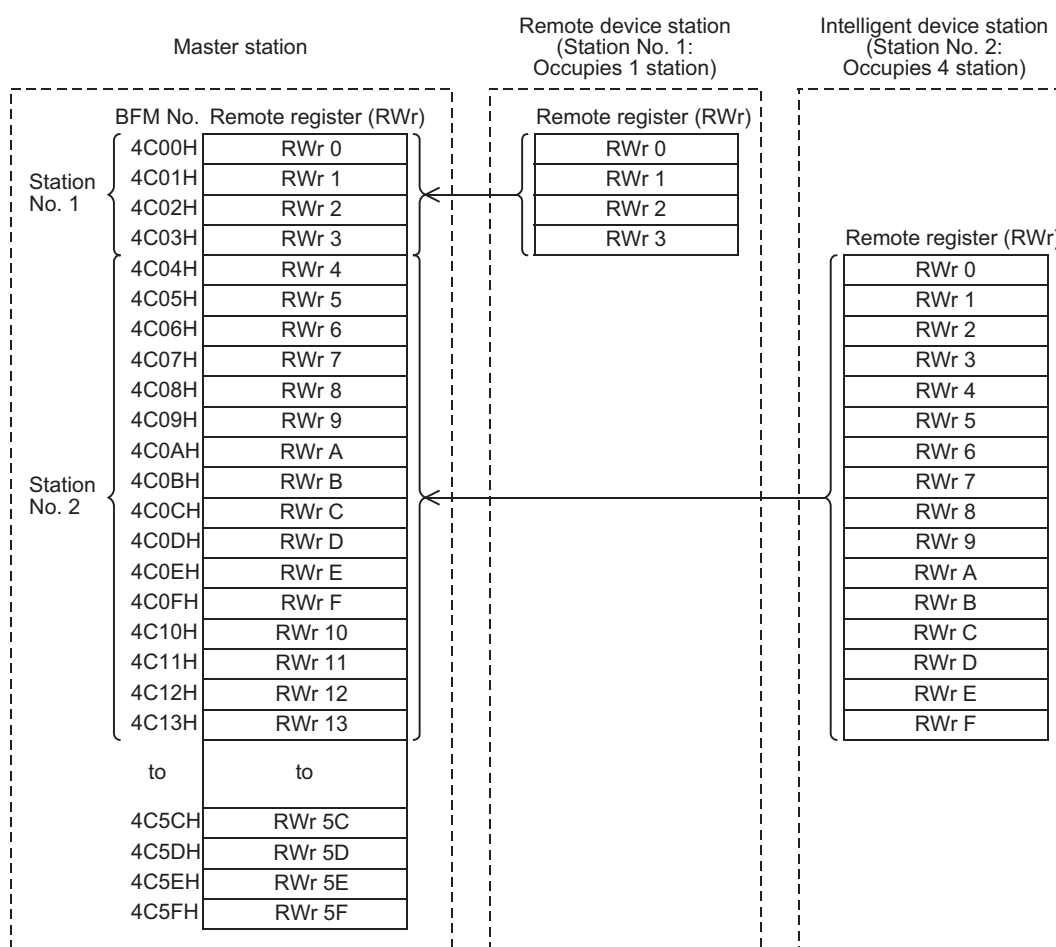

Caution

- When the TO instruction (or direct buffer memory specification) is executed, writing is invalid. When the FROM instruction (or direct buffer memory specification) is executed for reading from an area without assigned link points, the reading operation results in "0" being read.

11. Programming

11.1 Precautions in Programming

This section describes precautions in creating a program.

1. Create a read program from the remote input RX after data link startup. Create a write program to the remote output RY at the end of the entire program.

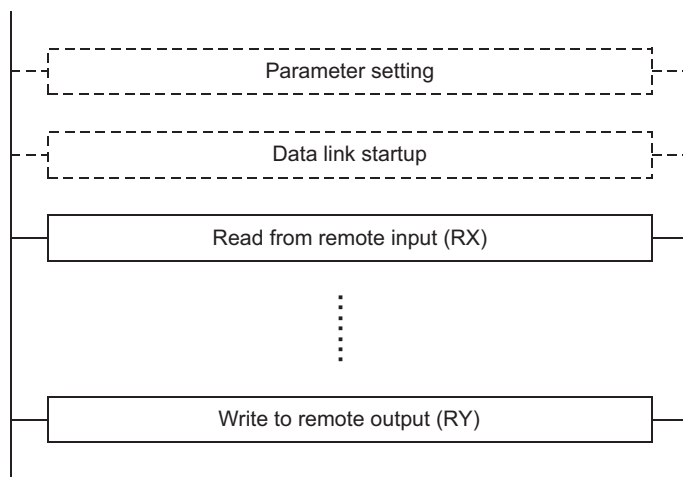

2. Create such a program that read of received data and write of transmission data are executed after the master station becomes the data link status (after the BFM#10 b1 turns ON).

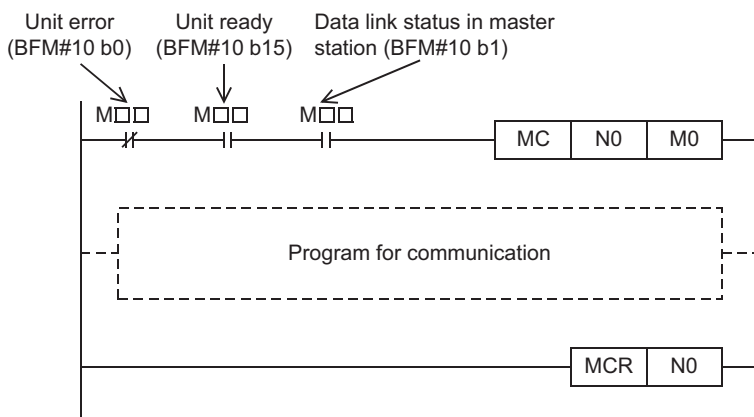

11

Programming

12

Remote I/O
Communication
Example

13

Remote Device
Communication
Example

14

Int. Device
Communication
Example

15

Compound Sys.
Communication
Example

16

Troubleshooting

A

Version
Information

B

Setting Sheet

C

Differences with
FX2N-16CCL-M

3. Create such a program that detects the data link status in remote I/O stations and remote device stations and intelligent device stations and executes interlock. Create a program for error handling.

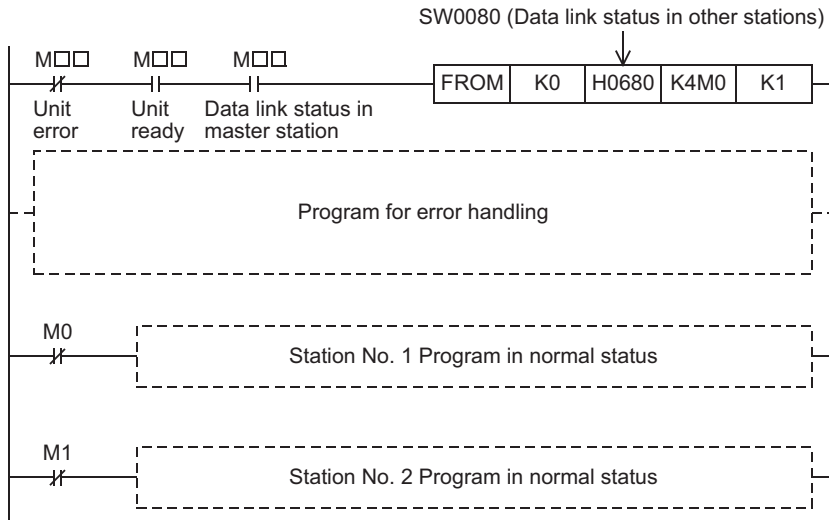

4. The auxiliary relays in the non-keep area (example: relays marked with "O") must be used as auxiliary relays (M) for parameter setting programs.

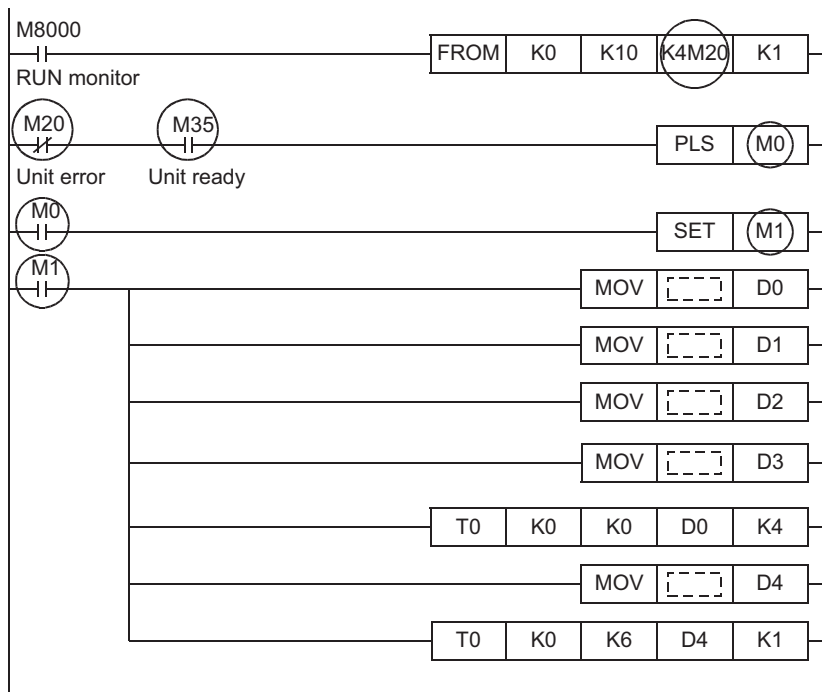

11.2 Link Special Relay (SB)/Link Special Register (SW)

The data link status can be checked using the bit information (link special relay SB) and the word information (link special register SW).

"SB" and "SW" represent the buffer memory information in the FX3U-16CCL-M, and can be read and written by the FROM/TO instruction (or direct buffer memory specification).

11.2.1 Link special relay (SB)

The data link status is stored in the form of bit ON/OFF information.

Buffer memory addresses 5E0H to 5FFH correspond to SB0000 to SB01FF.

The table below shows the relationship between the buffer memory addresses and link special relay.

→ For the details on the link special relay (SB0000 to SB01FF), refer to Subsection 10.12.1.

BFM No.		b15	b14	b13	b12	b11	b10	b9	b8	b7	b6	b5	b4	b3	b2	b1	b0
Hex.	Dec.																
5E0H	1504	F	E	D	C	B	A	9	8	7	6	5	4	3	2	1	0
5E1H	1505	1F	1E	1D	1C	1B	1A	19	18	17	16	15	14	13	12	11	10
5E2H	1506	2F	2E	2D	2C	2B	2A	29	28	27	26	25	24	23	22	21	20
5E3H	1507	3F	3E	3D	3C	3B	3A	39	38	37	36	35	34	33	32	31	30
5E4H	1508	4F	4E	4D	4C	4B	4A	49	48	47	46	45	44	43	42	41	40
5E5H	1509	5F	5E	5D	5C	5B	5A	59	58	57	56	55	54	53	52	51	50
5E6H	1510	6F	6E	6D	6C	6B	6A	69	68	67	66	65	64	63	62	61	60
5E7H	1511	7F	7E	7D	7C	7B	7A	79	78	77	76	75	74	73	72	71	70
5E8H	1512	8F	8E	8D	8C	8B	8A	89	88	87	86	85	84	83	82	81	80
5E9H	1513	9F	9E	9D	9C	9B	9A	99	98	97	96	95	94	93	92	91	90
5EAH	1514	AF	AE	AD	AC	AB	AA	A9	A8	A7	A6	A5	A4	A3	A2	A1	A0
5EBH	1515	BF	BE	BD	BC	BB	BA	B9	B8	B7	B6	B5	B4	B3	B2	B1	B0
5ECH	1516	CF	CE	CD	CC	CB	CA	C9	C8	C7	C6	C5	C4	C3	C2	C1	C0
5EDH	1517	DF	DE	DD	DC	DB	DA	D9	D8	D7	D6	D5	D4	D3	D2	D1	D0
5EEH	1518	EF	EE	ED	EC	EB	EA	E9	E8	E7	E6	E5	E4	E3	E2	E1	E0
5EFH	1519	FF	FE	FD	FC	FB	FA	F9	F8	F7	F6	F5	F4	F3	F2	F1	F0
5F0H	1520	10F	10E	10D	10C	10B	10A	109	108	107	106	105	104	103	102	101	100
5F1H	1521	11F	11E	11D	11C	11B	11A	119	118	117	116	115	114	113	112	111	110
5F2H	1522	12F	12E	12D	12C	12B	12A	129	128	127	126	125	124	123	122	121	120
5F3H	1523	13F	13E	13D	13C	13B	13A	139	138	137	136	135	134	133	132	131	130
5F4H	1524	14F	14E	14D	14C	14B	14A	149	148	147	146	145	144	143	142	141	140
5F5H	1525	15F	15E	15D	15C	15B	15A	159	158	157	156	155	154	153	152	151	150
5F6H	1526	16F	16E	16D	16C	16B	16A	169	168	167	166	165	164	163	162	161	160
5F7H	1527	17F	17E	17D	17C	17B	17A	179	178	177	176	175	174	173	172	171	170
5F8H	1528	18F	18E	18D	18C	18B	18A	189	188	187	186	185	184	183	182	181	180
5F9H	1529	19F	19E	19D	19C	19B	19A	199	198	197	196	195	194	193	192	191	190
5FAH	1530	1AF	1AE	1AD	1AC	1AB	1AA	1A9	1A8	1A7	1A6	1A5	1A4	1A3	1A2	1A1	1A0
5FBH	1531	1BF	1BE	1BD	1BC	1BB	1BA	1B9	1B8	1B7	1B6	1B5	1B4	1B3	1B2	1B1	1B0
5FCH	1532	1CF	1CE	1CD	1CC	1CB	1CA	1C9	1C8	1C7	1C6	1C5	1C4	1C3	1C2	1C1	1C0
5FDH	1533	1DF	1DE	1DD	1DC	1DB	1DA	1D9	1D8	1D7	1D6	1D5	1D4	1D3	1D2	1D1	1D0
5FEH	1534	1EF	1EE	1ED	1EC	1EB	1EA	1E9	1E8	1E7	1E6	1E5	1E4	1E3	1E2	1E1	1E0
5FFH	1535	1FF	1FE	1FD	1FC	1FB	1FA	1F9	1F8	1F7	1F6	1F5	1F4	1F3	1F2	1F1	1F0

11.2.2 Link special register (SW)

The data link status is stored in the form of word information.

Buffer memory addresses 600H to 7FFH correspond to SW0000 to SW01FF.

→ For the details on the link special register (SW0000 to SW01FF), refer to Subsection 10.12.2.

11

Programming

12

Remote I/O
Communication
Example

13

Remote Device
Communication
Example

14

Int. Device
Communication
Example

15

Compound Sys.
Communication
Example

16

Troubleshooting

A

Version
Information

B

Setting Sheet

C

Differences with
FX2N-16CCL-M

11.2.3 Update timing of the link special registers

The timing at which the data in the link special registers (SW) is updated varies depending on the register number as shown in the table below.

Link special register	Data update timing	Link special register	Data update timing
SW0041	Updated independently without regard to SB	SW0071	Updated independently without regard to SB (updated after each station is stabilized)
SW0045		SW0072	
SW0060	Updated when SB0060 changes	SW0074	Updated when SB0074 changes
SW0061	Updated when SB0061 changes	SW0078	Updated when SB0075 changes
SW0067	Updated independently without regard to SB	SW0080	Updated when SB0080 changes
SW0069		SW0088	Updated independently without regard to SB
SW006A		SW0098	
SW006D		SW009C	
SW006E		SW00B4	
SW006F		SW00B8	
SW0070		-	

12. Example of Communication between Master Station and Remote I/O Stations

This chapter explains the procedures from unit settings to parameter settings, programming, and finally operation check using a system configuration example.

The example which uses a FROM/TO instructions explains read/write of a buffer memory. For the other methods, refer to the programming manual.

For details on the remote I/O stations, refer to the each remote I/O stations manual.

12.1 System Configuration

It is supposed that three remote I/O stations are connected in the system.

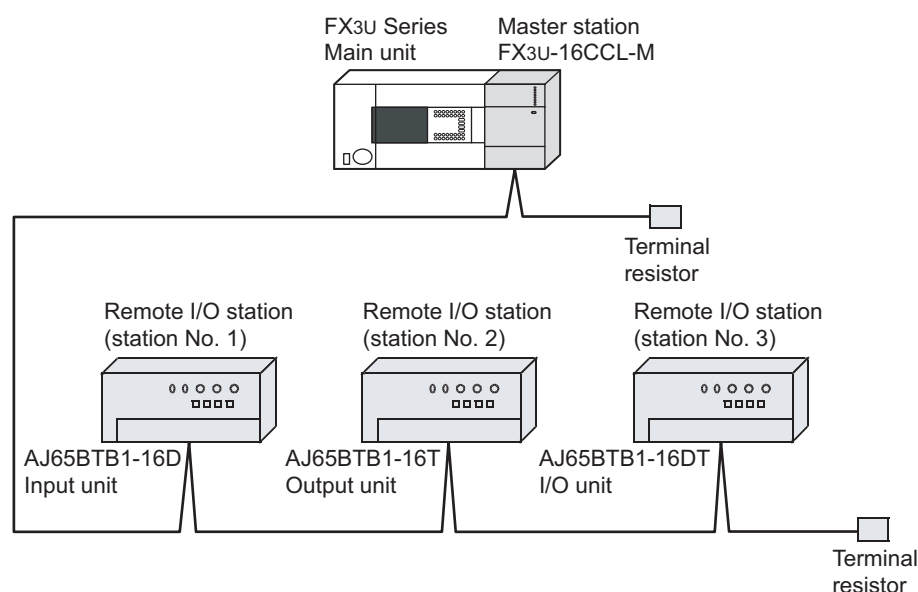

12.1.1 Setting of master station

The figure below shows the setting of the switches in the master station.

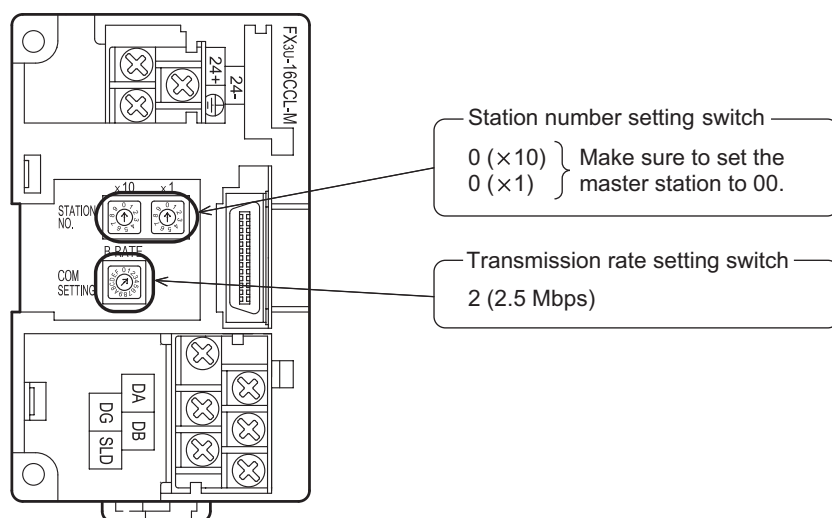

- 11 Programming
- 12 Remote I/O Communication Example
- 13 Remote Device Communication Example
- 14 Int. Device Communication Example
- 15 Compound Sys. Communication Example
- 16 Troubleshooting
- A Version Information
- B Setting Sheet
- C Differences with FX2N-16CCL-M

12.1.2 Setting of remote I/O station

The figure below shows the setting of the switches in the remote I/O station.

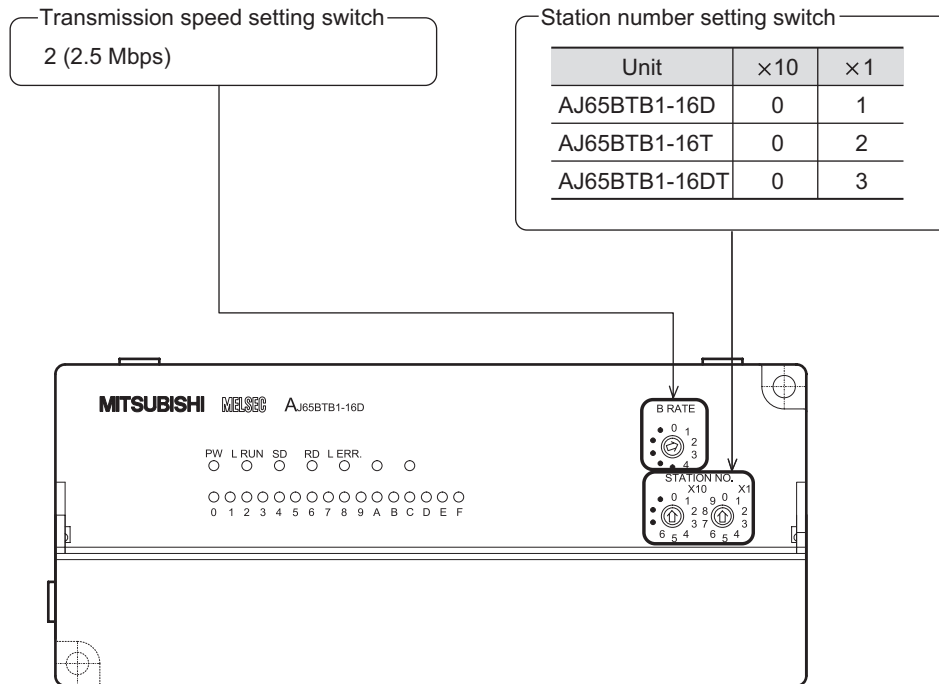

12.1.3 Setting of parameters

This Subsection describes parameter setup for performing a data link. This subsection describes parameter setup for performing data link using a sequence program. Refer to Section 8.5 for the setting method using network parameters. The program for parameters shown below is not required when parameters are set using network parameters.

1. Program for parameters

In the program below, data link automatically starts when the PLC starts to run.

Caution

The auxiliary relays in the non-keep area must be used as auxiliary relays (M) for parameter setting programs.

→ For the precautions in programming, refer to Section 11.1.

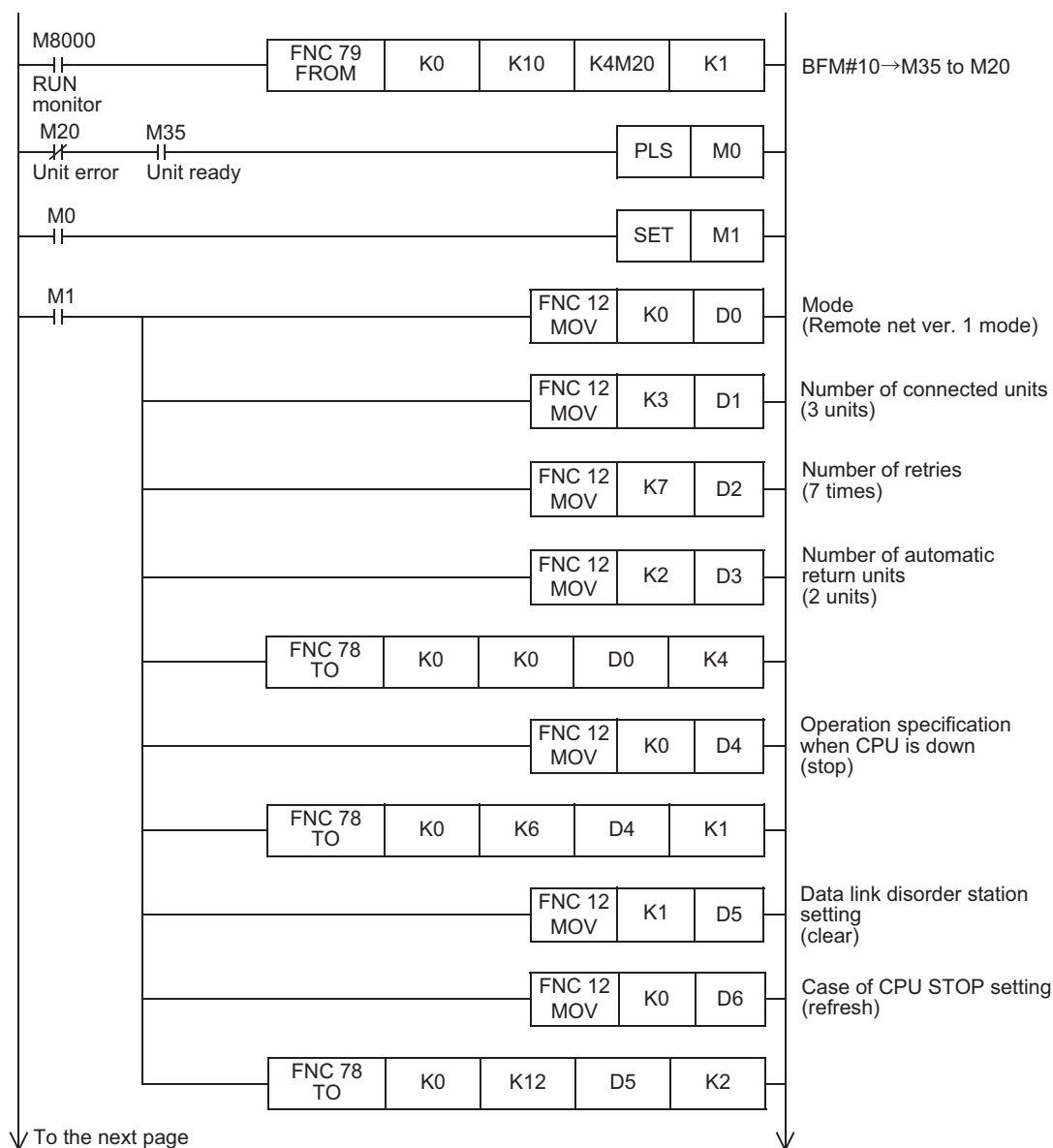

11 Programming

12 Remote I/O Communication Example

13 Remote Device Communication Example

14 Int. Device Communication Example

15 Compound Sys. Communication Example

16 Troubleshooting

A Version Information

B Setting Sheet

C Differences with FX2N-16CCL-M

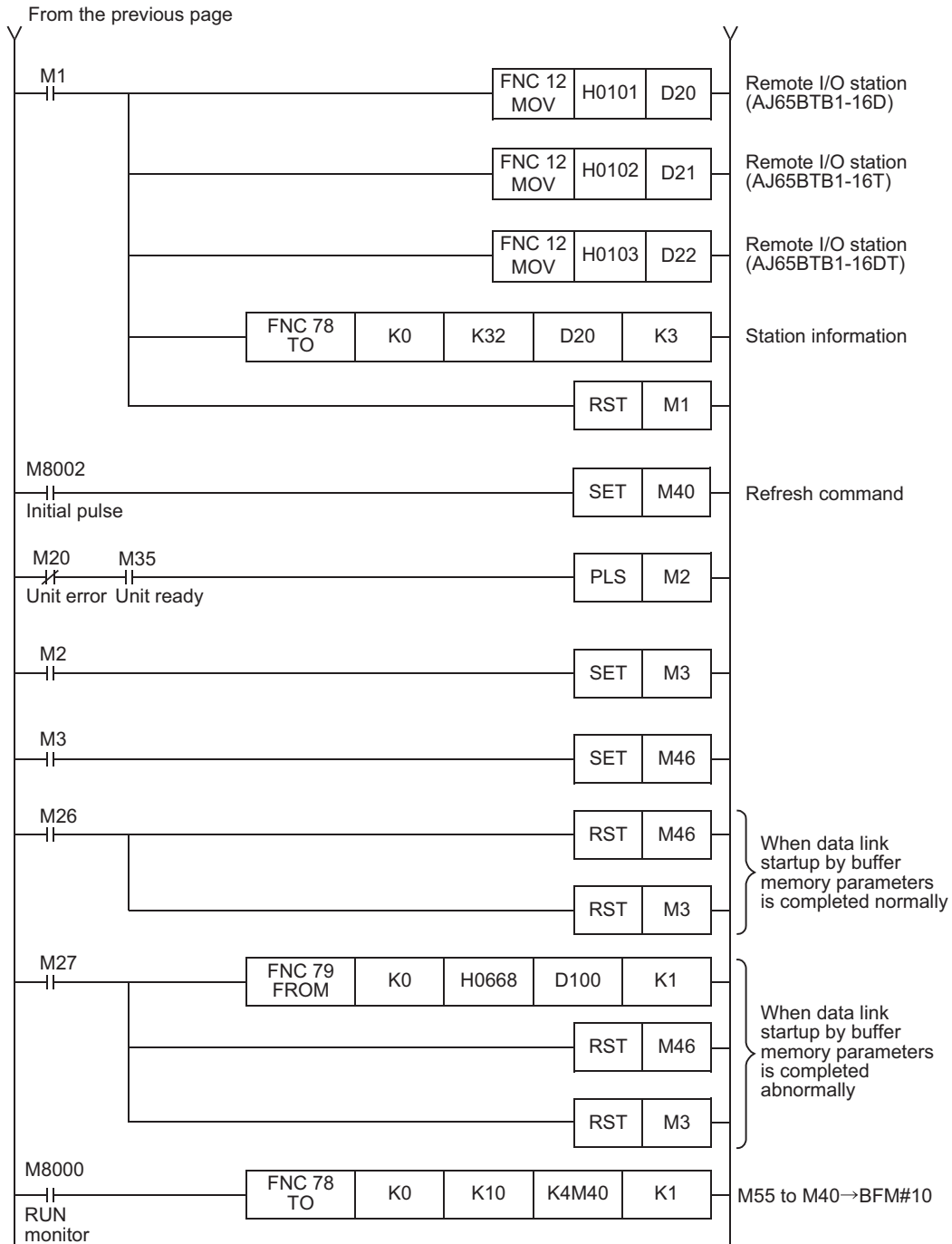

12.1.4 Creating a program for communication

This Subsection describes a program to control remote I/O stations.

- The relationship among the PLC, the master station buffer memory and the remote I/O stations.

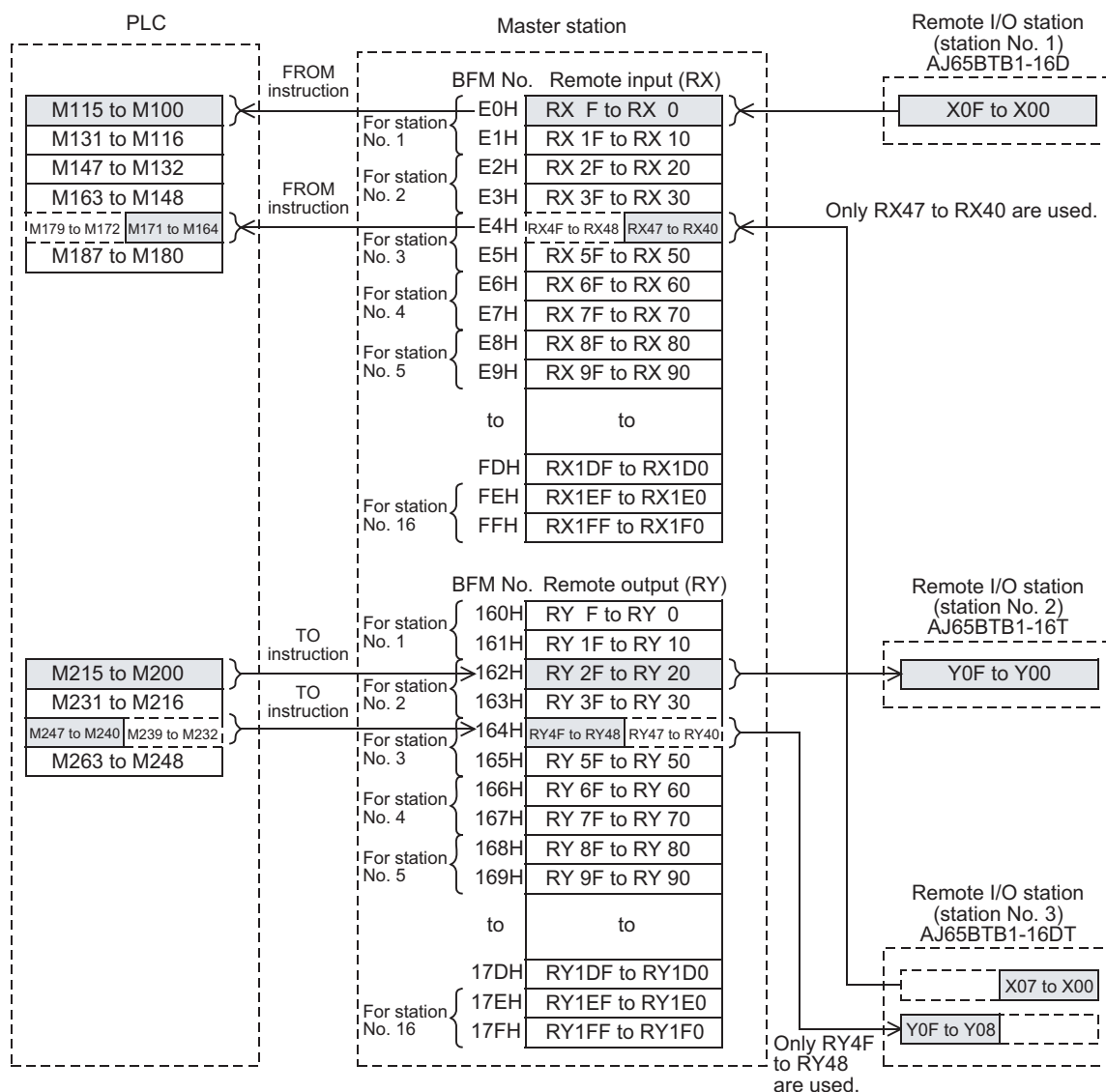

11 Programming

12 Remote I/O Communication Example

13 Remote Device Communication Example

14 Int. Device Communication Example

15 Compound Sys. Communication Example

16 Troubleshooting

A Version Information

B Setting Sheet

C Differences with FX2N-16CCL-M

• Program to control remote I/O stations

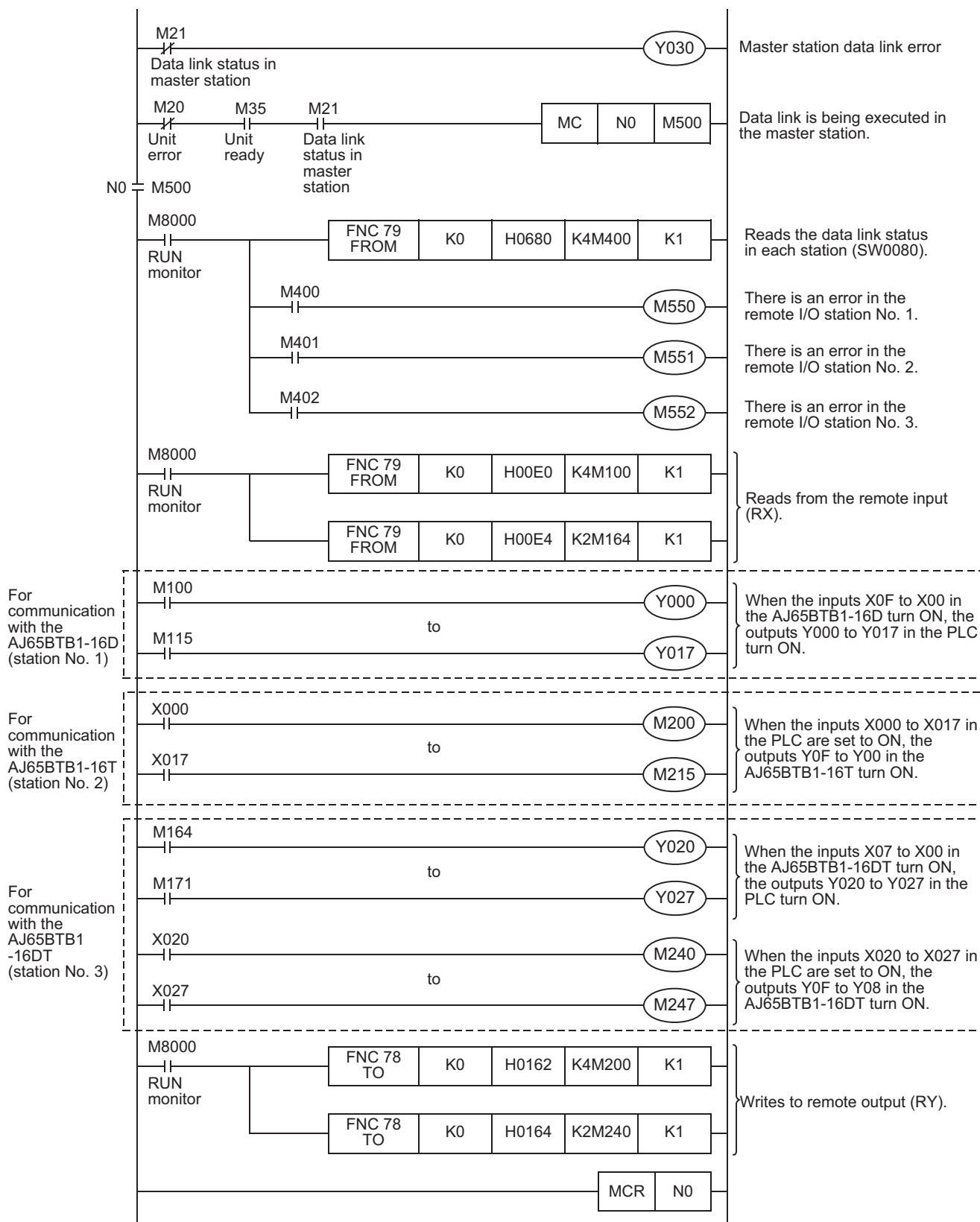

12.1.5 Execution of data link

Turn on the power of the remote I/O stations first, turn on the power of the master station, then start the data link.

1. Confirmation of operation by LED indication

The figures below show the LED indication status in the master station and the remote I/O stations while the data link is normally proceeding.

- LED indication in the master station

Make sure that the LED indication status is as shown below.

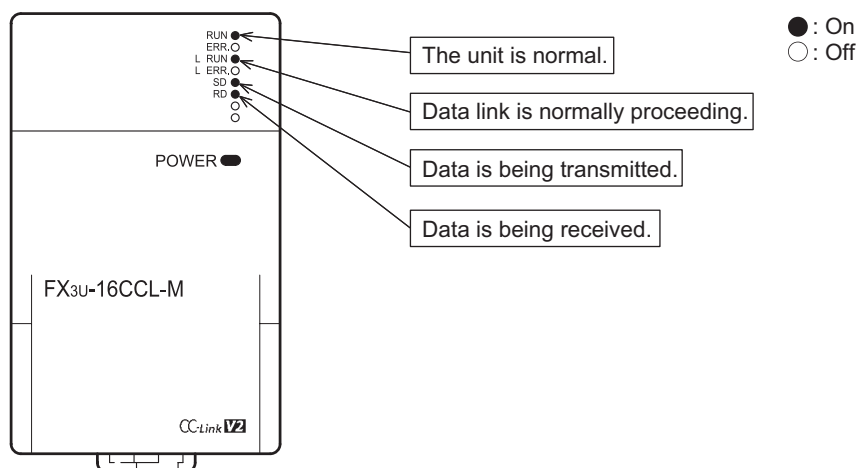

- LED indication in the remote I/O station

Make sure that the LED indication status is as shown below.

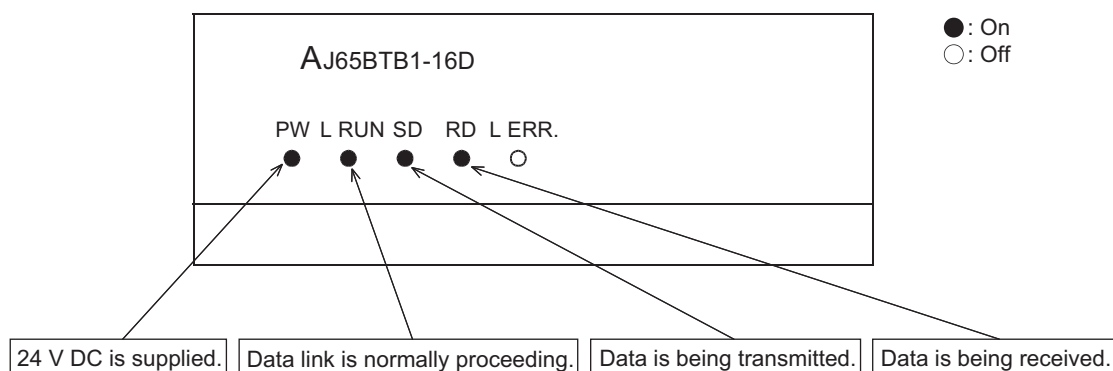

11 Programming

12 Remote I/O Communication Example

13 Remote Device Communication Example

14 Int. Device Communication Example

15 Compound Sys. Communication Example

16 Troubleshooting

A Version Information

B Setting Sheet

C Differences with FX2N-16CCL-M

2. Confirmation of operation by program

Using a sequence program, make sure that data link is normally proceeding.

- 1) When the input X00 in the AJ65BTB1-16D (station No. 1) is set to ON, the output Y000 in the master station PLC turns ON.
- 2) When the input X000 in the master station PLC is set to ON, the output Y00 in the AJ65BTB1-16T (station No. 2) turns ON.

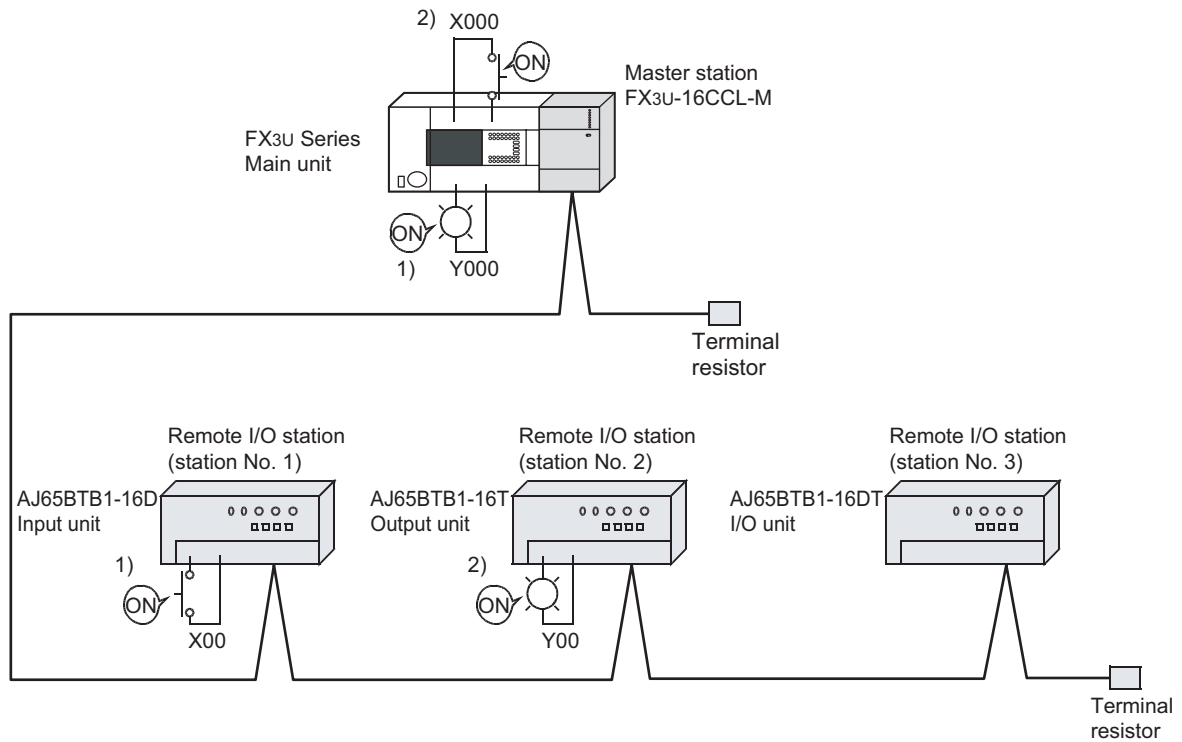

13. Example of Communication between Master Station and Remote Device Stations

This chapter explains the procedures from unit settings to parameter settings, programming, and finally operation check using a system configuration example. The example which uses a FROM/TO instructions explains read/write of a buffer memory. For the other methods, refer to the programming manual. For details on the remote device stations, refer to the each remote device stations manual.

13.1 When Remote Net Ver. 1 Mode is Used

13.1.1 System configuration

It is supposed that two remote device stations are connected in the system.

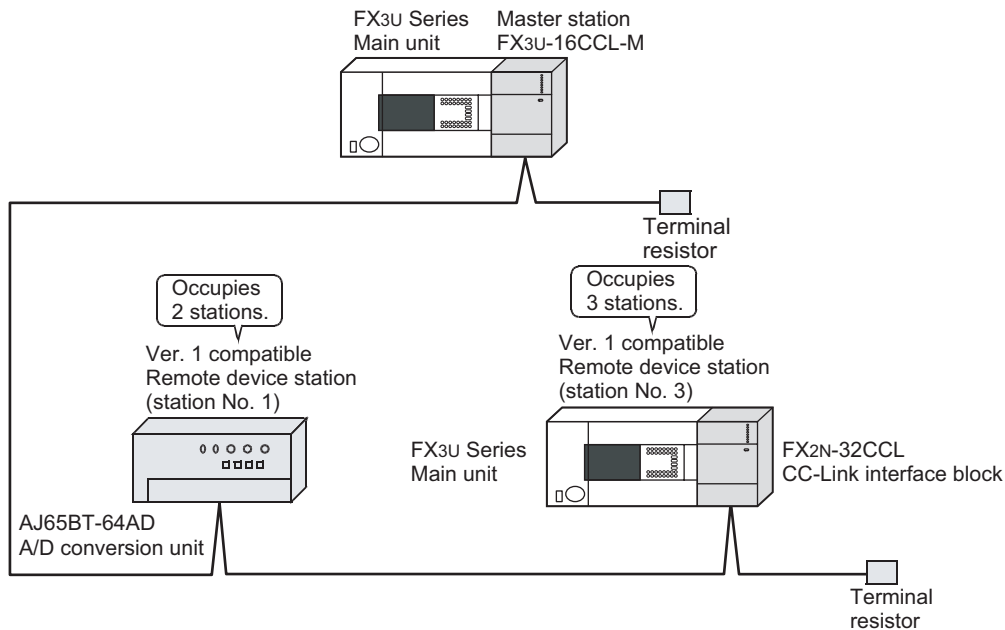

13.1.2 Setting of master station

The figure below shows the setting of the switches in the master station.

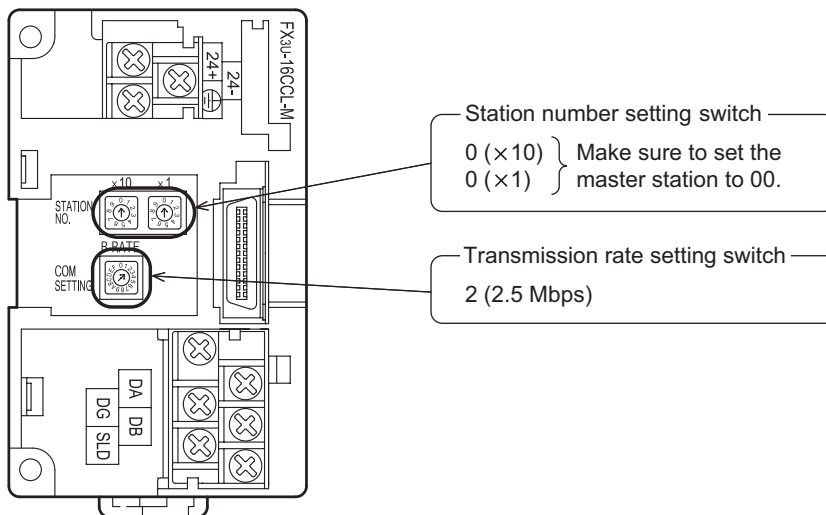

11 Programming

12 Remote I/O Communication Example

13 Remote Device Communication Example

14 Int. Device Communication Example

15 Compound Sys. Communication Example

16 Troubleshooting

A Version Information

B Setting Sheet

C Differences with FX2N-16CCL-M

13.1.3 Setting of remote device station

The figure below shows the setting of the switches in the remote device station.

- AJ65BT-64AD

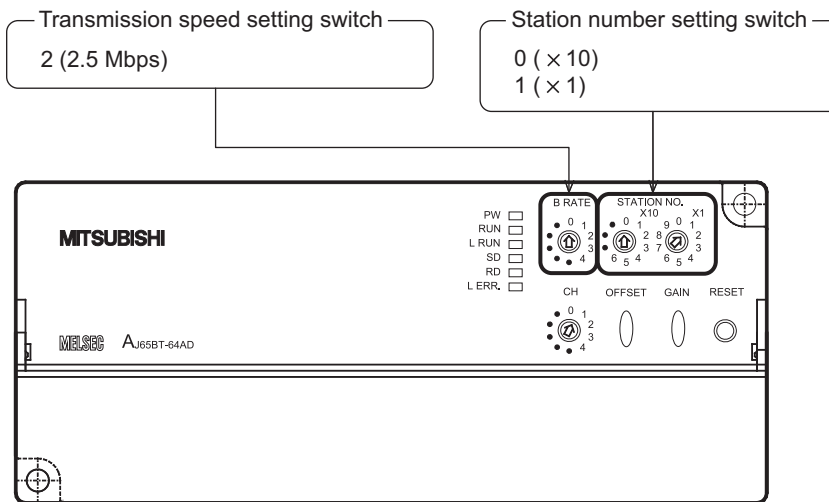

- FX2N-32CCL

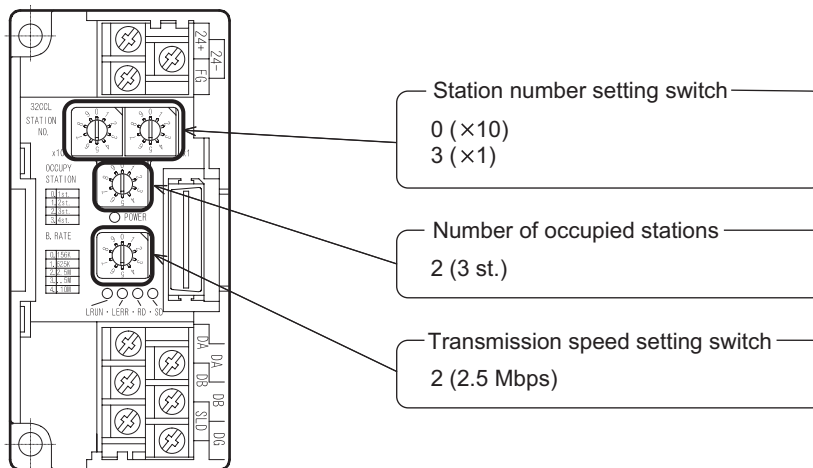

13.1.4 Setting of parameters

This Subsection describes parameter setup for performing a data link. This subsection describes parameter setup for performing data link using a sequence program. Refer to Section 8.5 for the setting method using network parameters. The program for parameters shown below is not required when parameters are set using network parameters.

1. Program for parameters

In the program below, data link automatically starts when the PLC starts to run.

Caution

The auxiliary relays in the non-keep area must be used as auxiliary relays (M) for parameter setting programs.

→ For the precautions in programming, refer to Section 11.1.

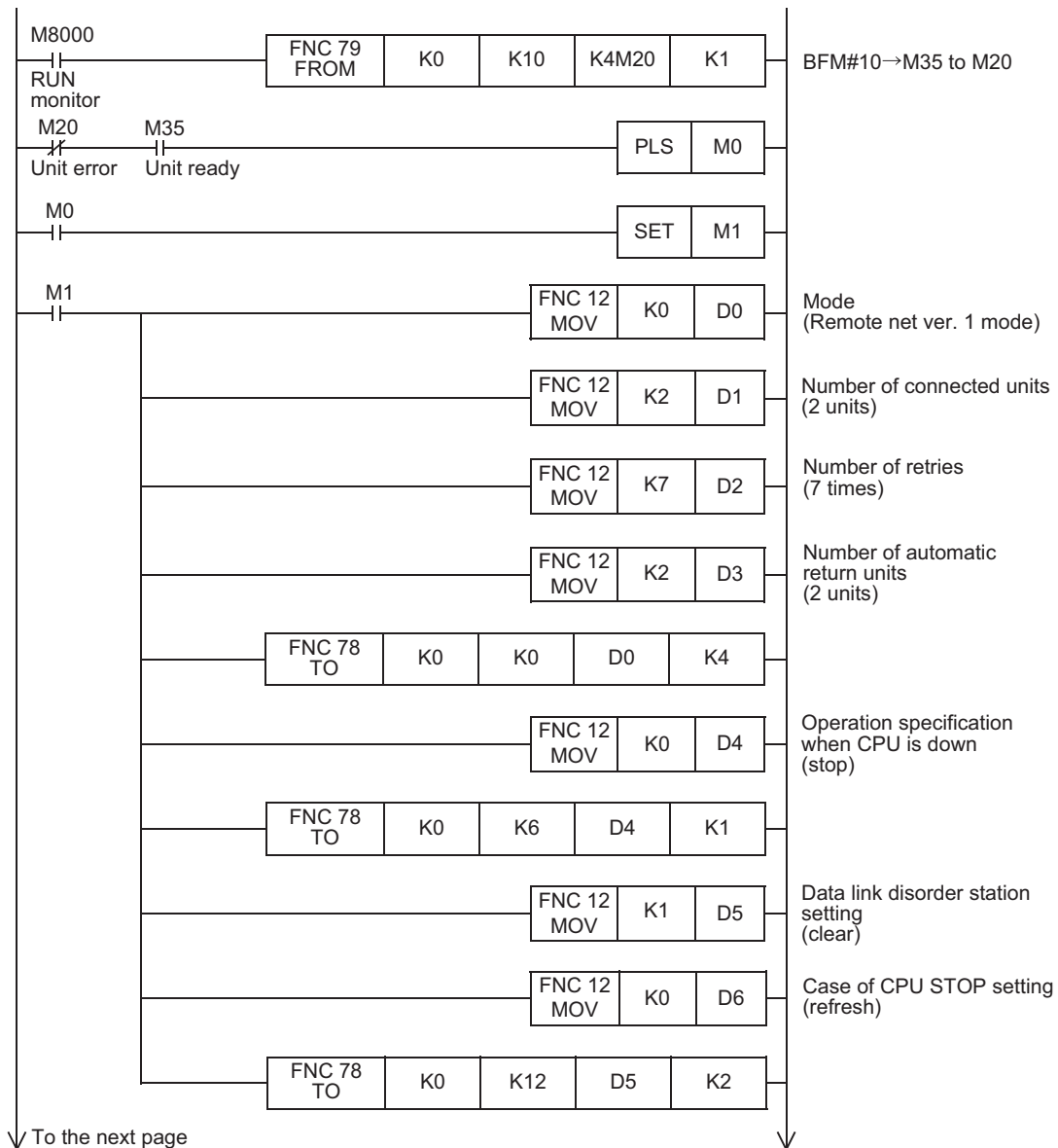

11	Programming
12	Remote I/O Communication Example
13	Remote Device Communication Example
14	Int. Device Communication Example
15	Compound Sys. Communication Example
16	Troubleshooting
A	Version Information
B	Setting Sheet
C	Differences with FX2N-16CCL-M

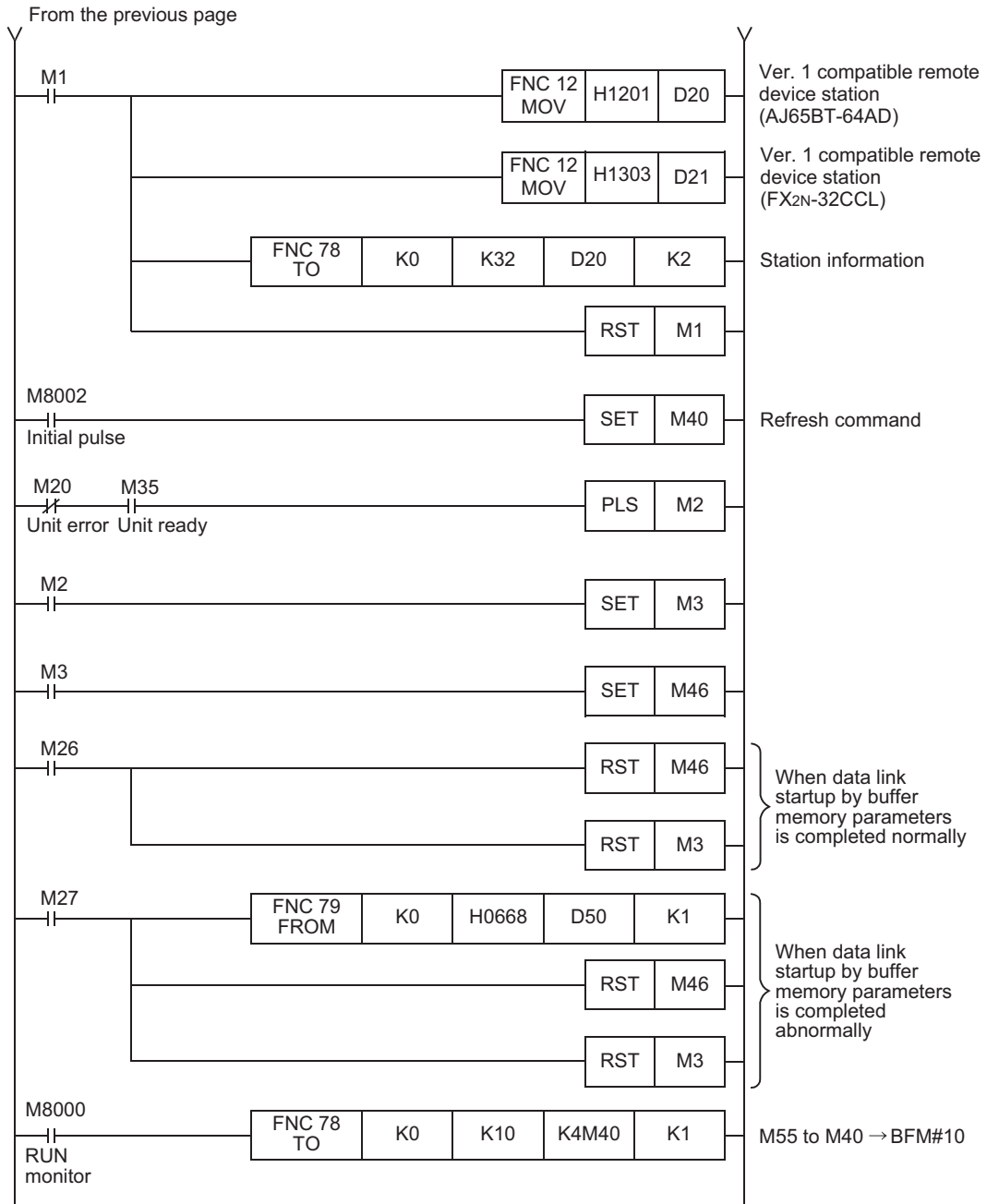

13.1.5 Creating a program for communication

This Subsection describes a program to control remote device stations.

- The relationship among the PLC, the master station buffer memory and the remote device stations.
 - Remote input (RX) and remote output (RY)

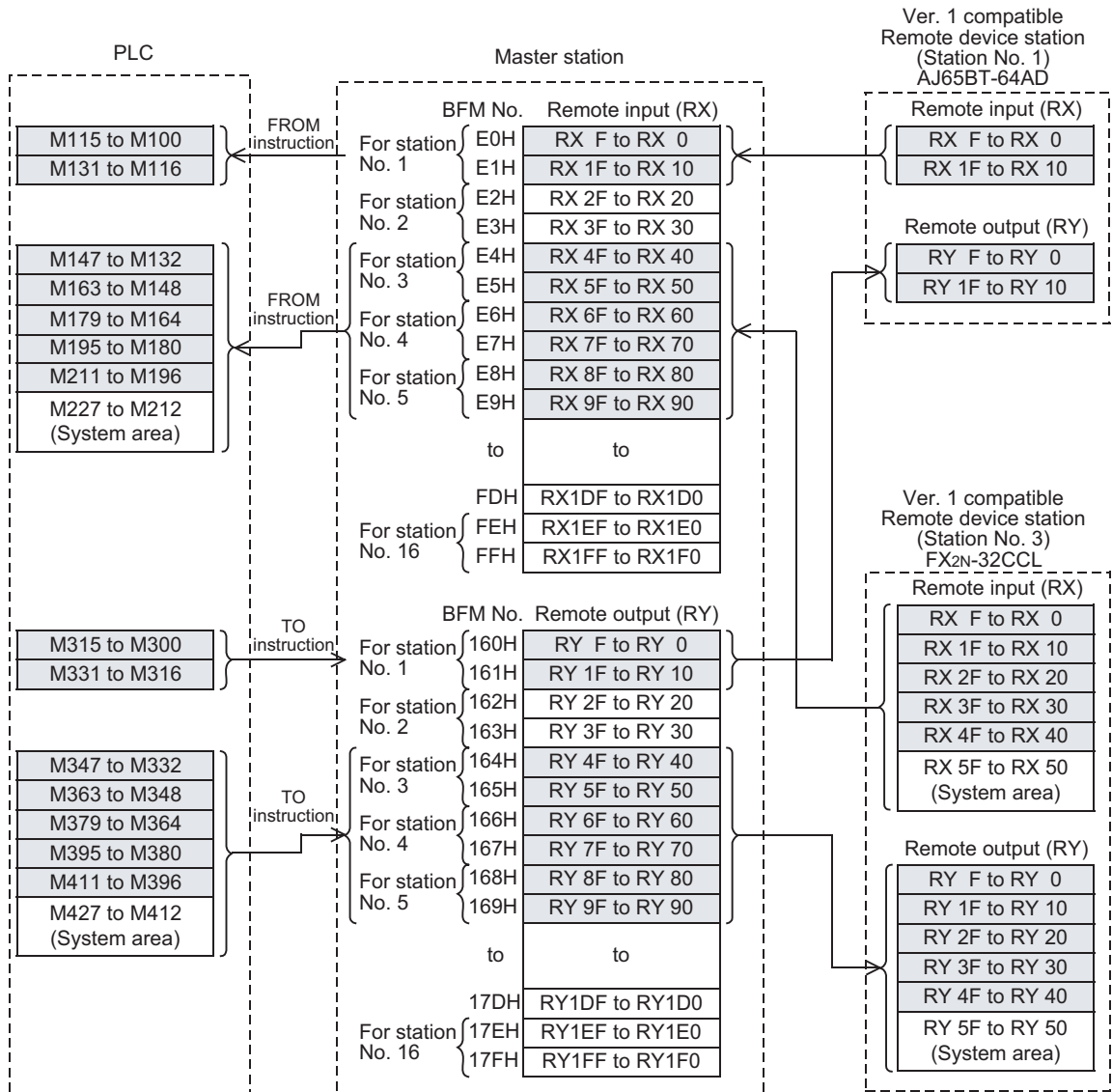

11	Programming
12	Remote I/O Communication Example
13	Remote Device Communication Example
14	Int. Device Communication Example
15	Compound Sys. Communication Example
16	Troubleshooting
A	Version Information
B	Setting Sheet
C	Differences with FX2N-16CCL-M

- Remote register (RWw, RWr)

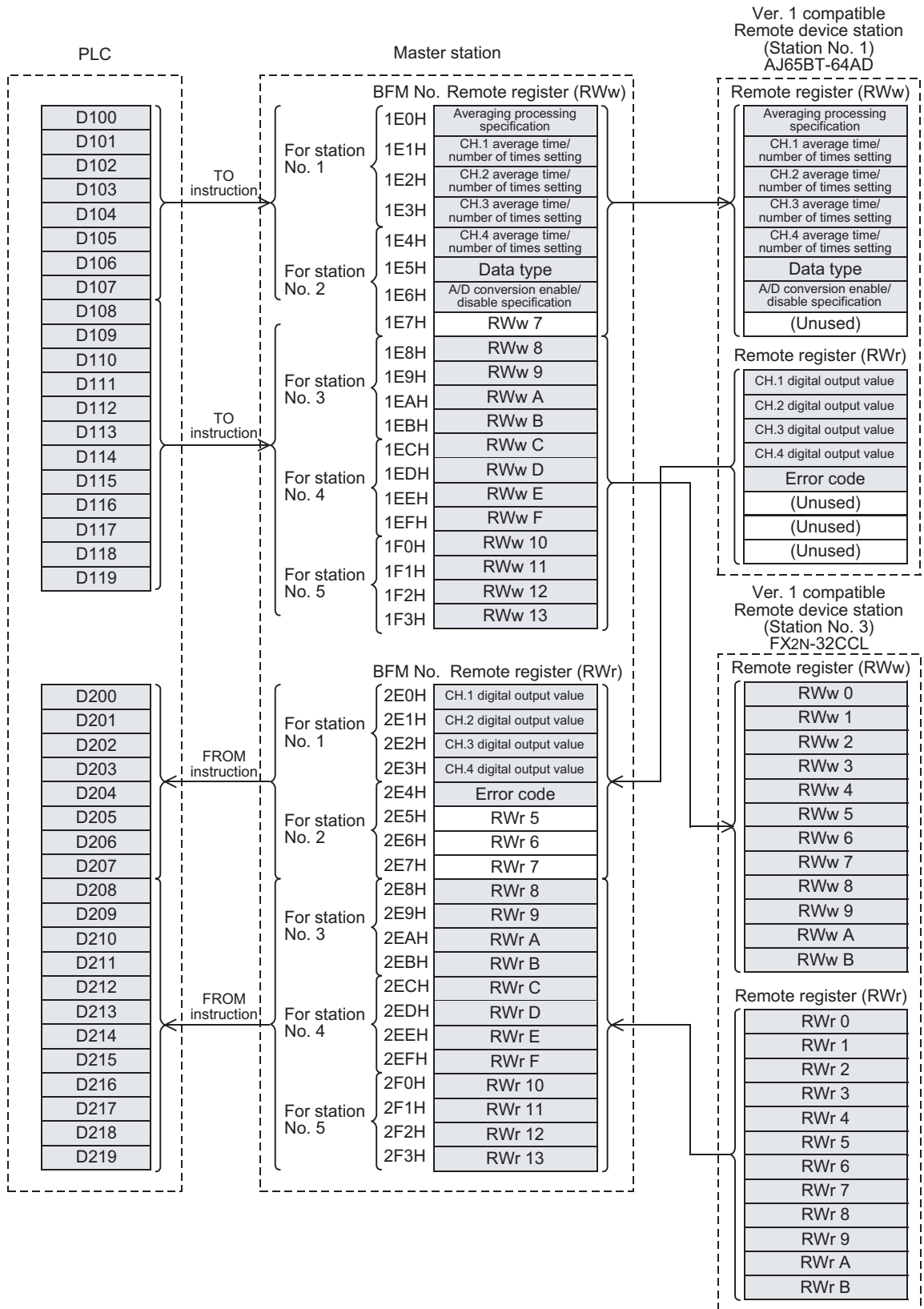

• Program to control remote device stations

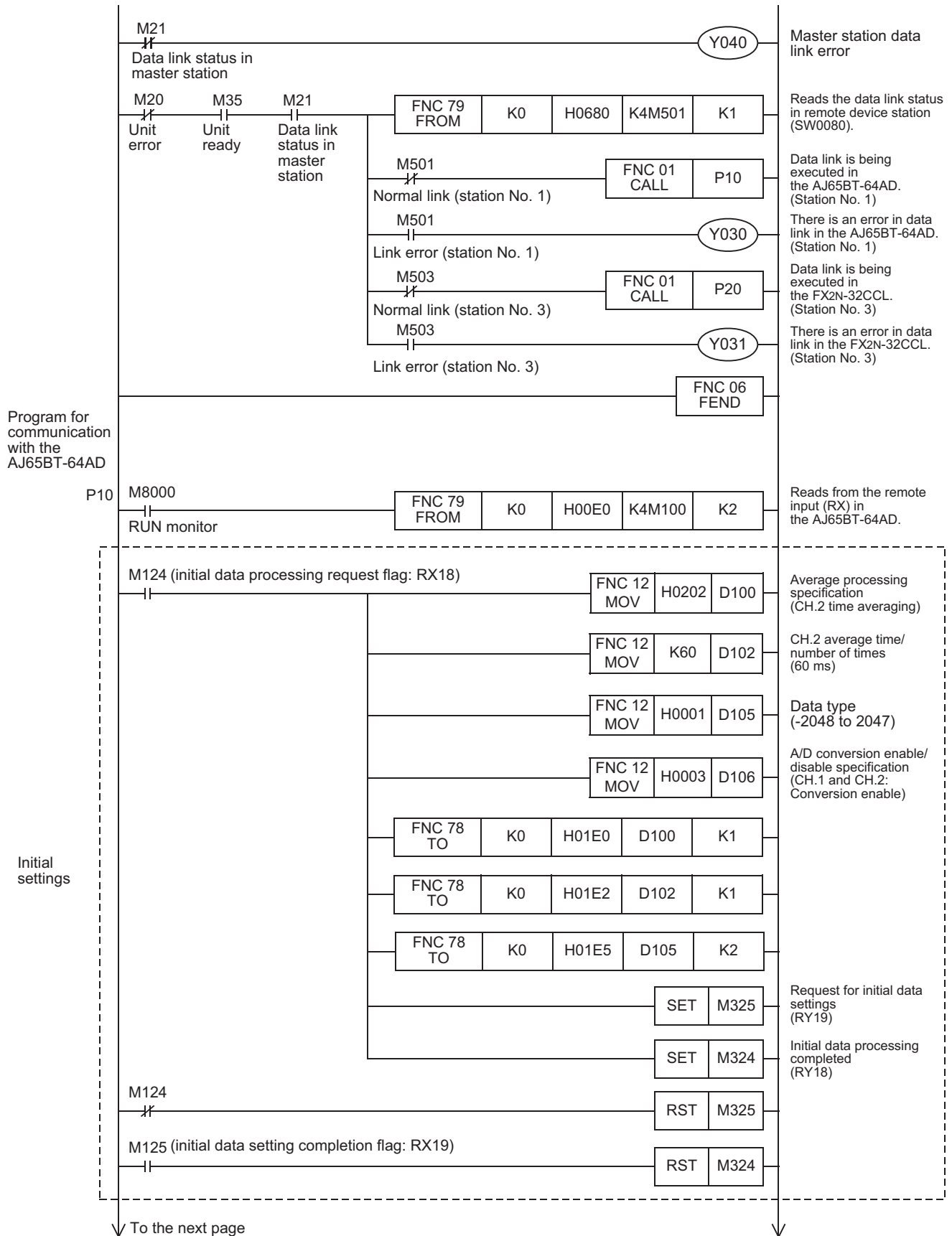

11	Programming
12	Remote I/O Communication Example
13	Remote Device Communication Example
14	Int. Device Communication Example
15	Compound Sys. Communication Example
16	Troubleshooting
A	Version Information
B	Setting Sheet
C	Differences with FX2N-16CCL-M

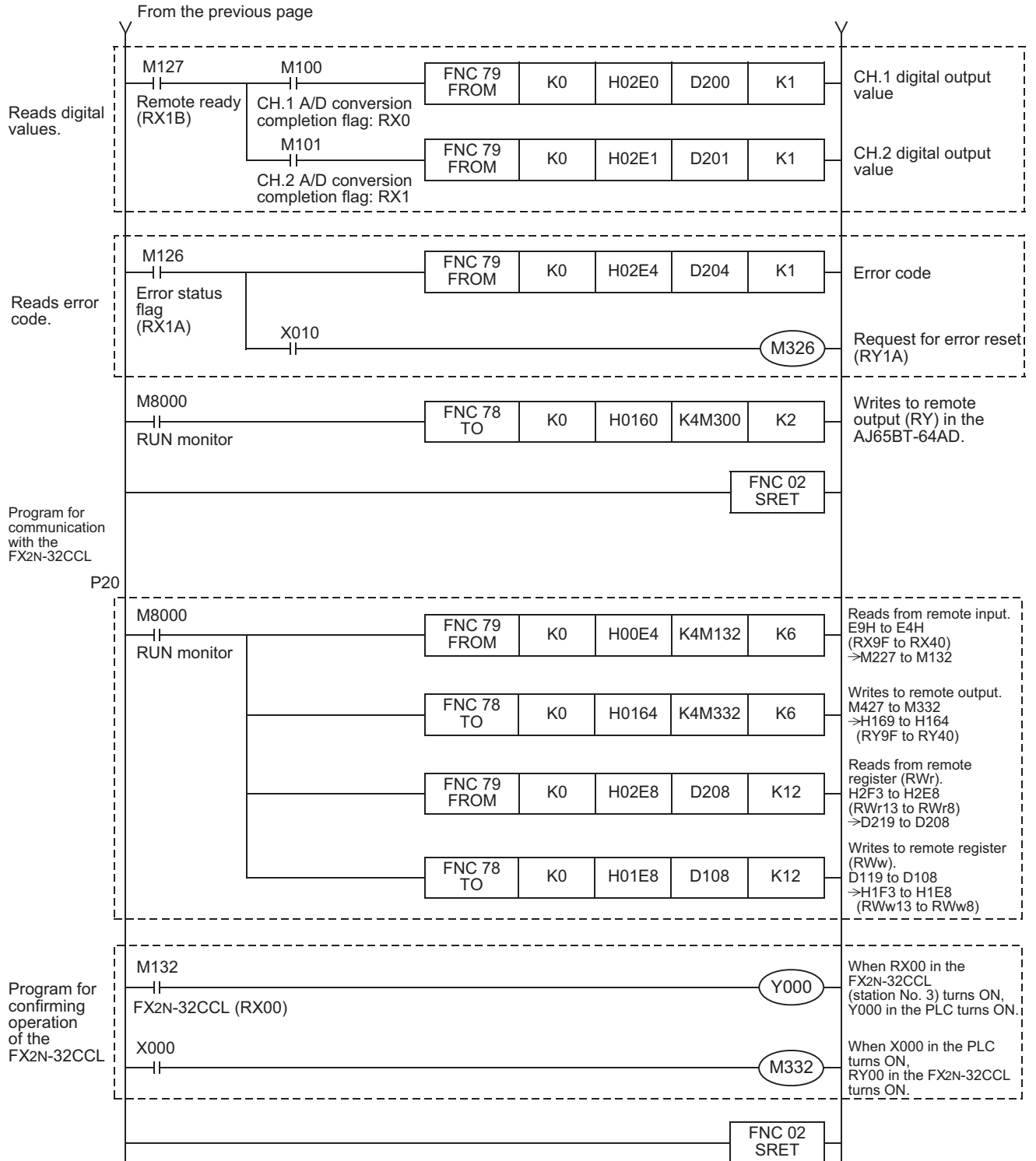

13.1.6 Execution of data link

Turn on the power of the remote device stations first, turn on the power of the master station, then start the data link.

13.1.7 Confirmation of operation by LED indication

The figures below show the LED indication status in the master station and the remote device stations while the data link is normally proceeding.

- LED indication in the master station
Make sure that the LED indication status is as shown below.

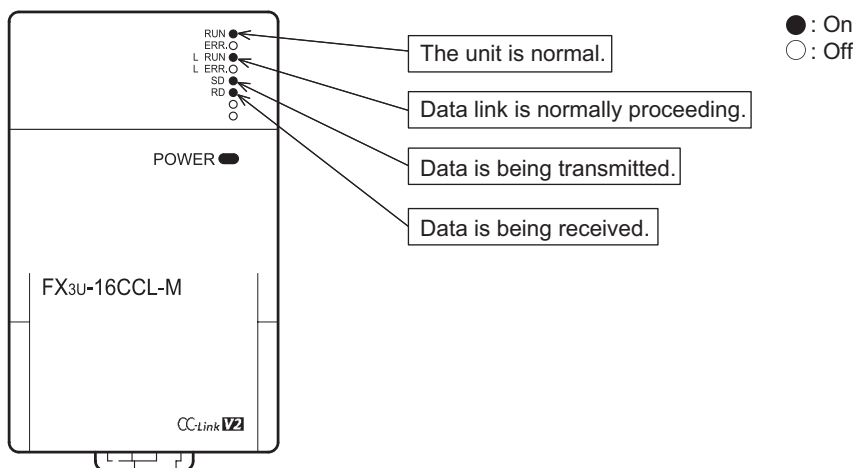

- LED indication in the remote device station
Make sure that the LED indication status is as shown below.
- AJ65BT-64AD

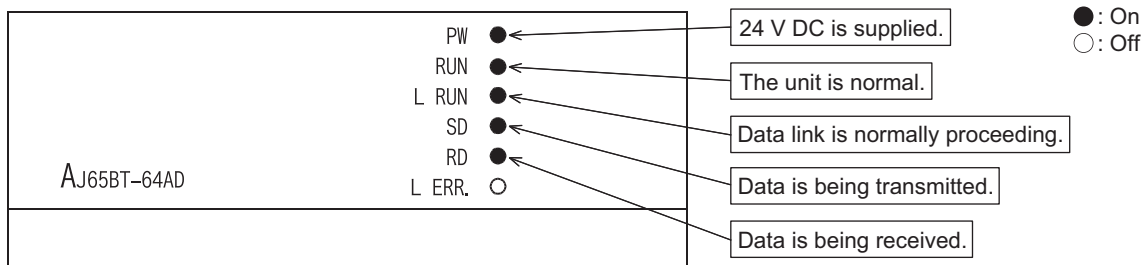

- FX2N-32CCL

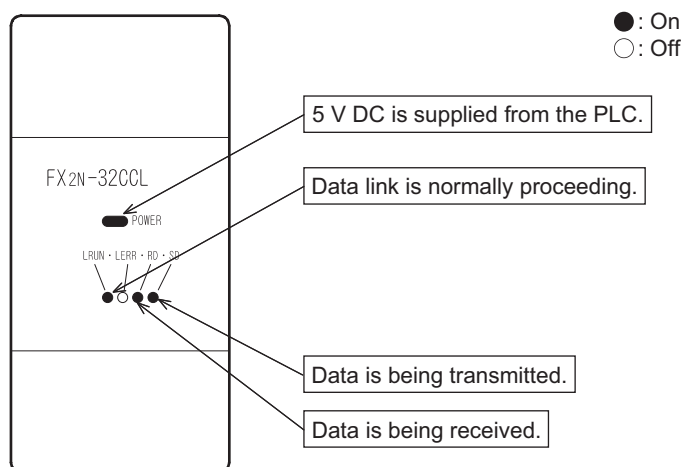

11 Programming

12 Remote I/O Communication Example

13 Remote Device Communication Example

14 Int. Device Communication Example

15 Compound Sys. Communication Example

16 Troubleshooting

A Version Information

B Setting Sheet

C Differences with FX2N-16CCL-M

13.1.8 Confirmation of operation by program

Using a sequence program, make sure that data link is normally proceeding.

- 1) The digital values converted by the AJ65BT-64AD (station No. 1) are stored in D200 (CH1 digital value) and D201 (CH2 digital value).
- 2) When X000 in the master station PLC turns ON, RY00 in the FX2N-32CCL (station No. 3) turns ON.
- 3) When RX00 in the FX2N-32CCL (station No. 3) turns ON, Y000 (M132) in the master station PLC turns ON.

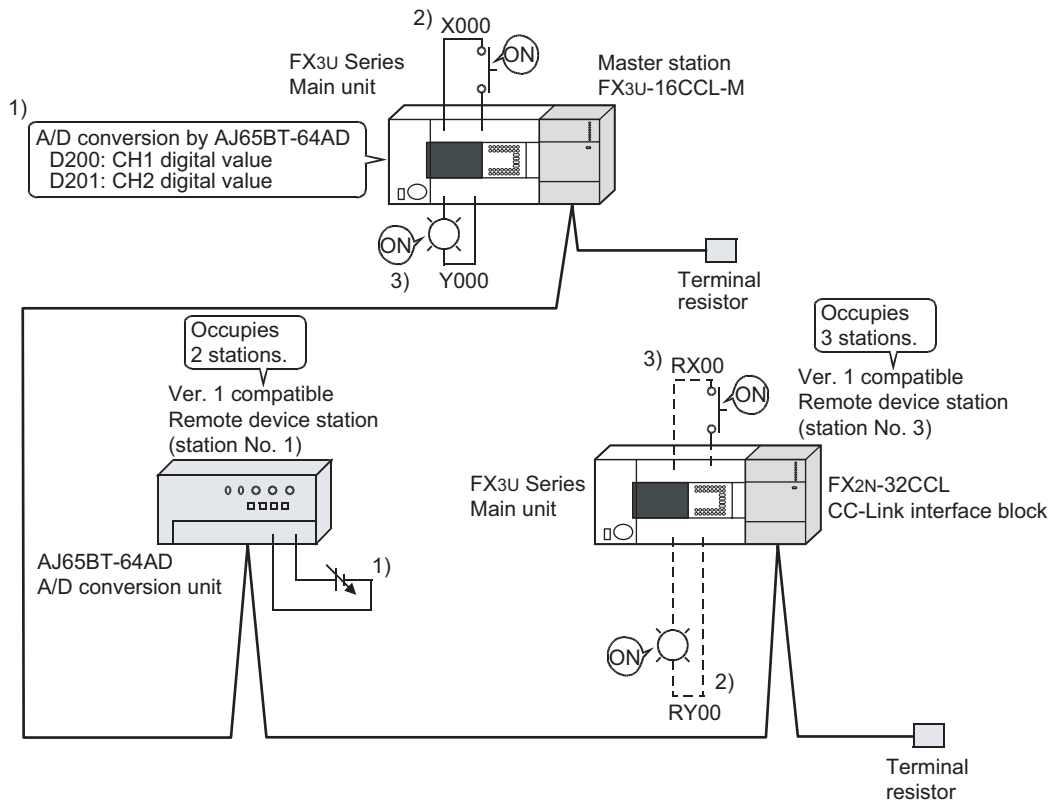

Caution

A program for communication is required also in the FX3U Series main unit connected to the FX2N-32CCL.

13.2 When Remote Net Ver. 2 Mode is Used

13.2.1 System configuration

It is supposed that one ver.1 compatible remote device station and one ver.2 compatible remote device station are connected in the system.

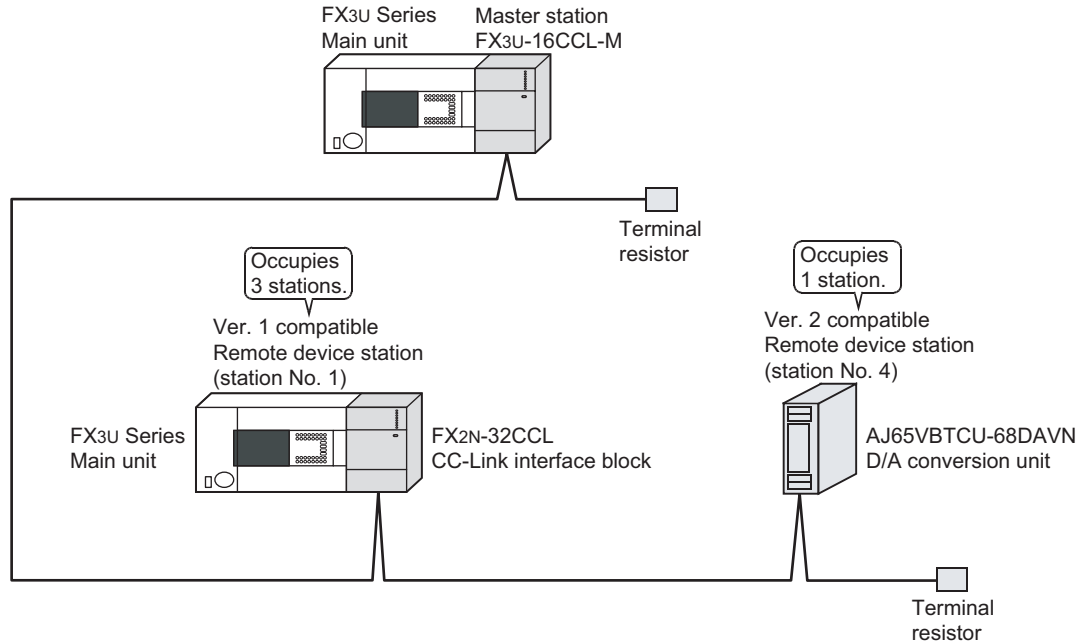

13.2.2 Setting of master station

The figure below shows the setting of the switches in the master station.

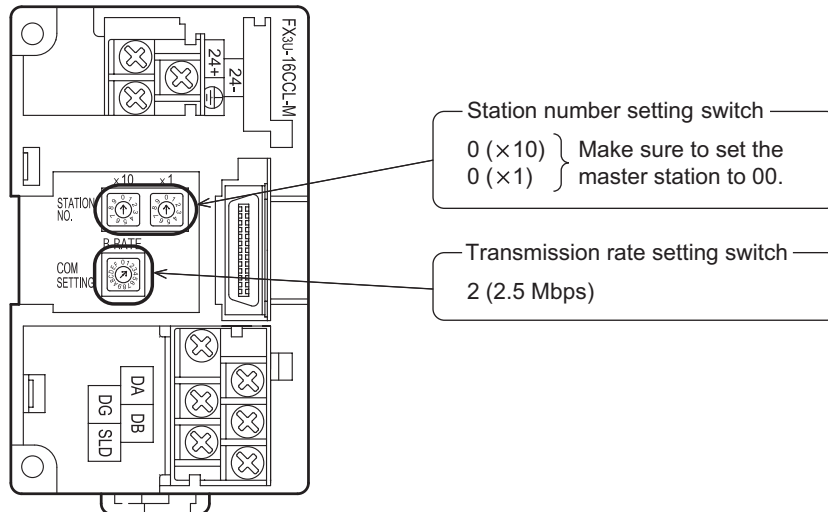

13.2.3 Setting of remote device station

The figure below shows the setting of the switches in the remote device station.

- FX2N-32CCL

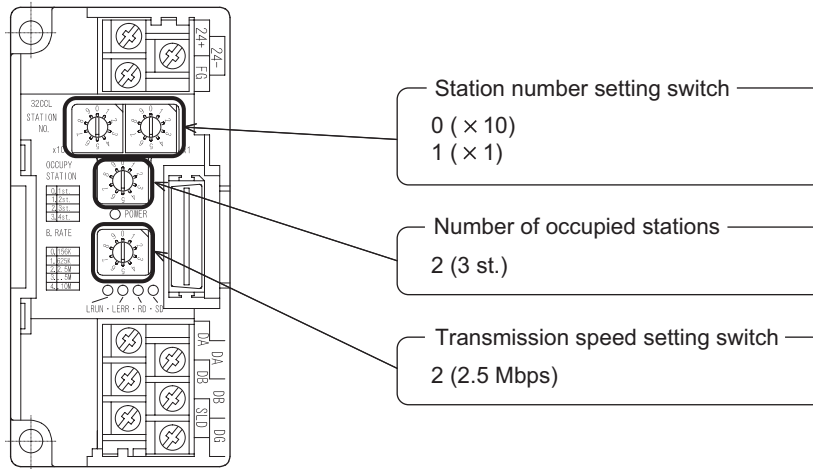

- AJ65VBTCU-68DAVN

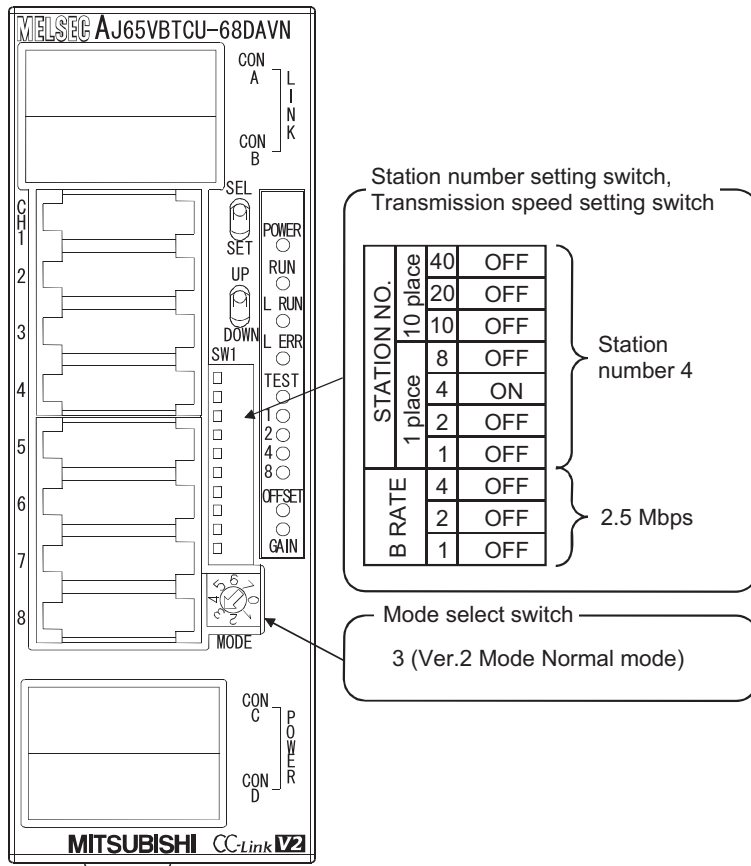

13.2.4 Setting of parameters

This Subsection describes parameter setup for performing a data link. This subsection describes parameter setup for performing data link using a sequence program. Refer to Section 8.5 for the setting method using network parameters. The program for parameters shown below is not required when parameters are set using network parameters.

1. Program for parameters

In the program below, data link automatically starts when the PLC starts to run.

Caution

The auxiliary relays in the non-keep area must be used as auxiliary relays (M) for parameter setting programs.

→ For the precautions in programming, refer to Section 11.1.

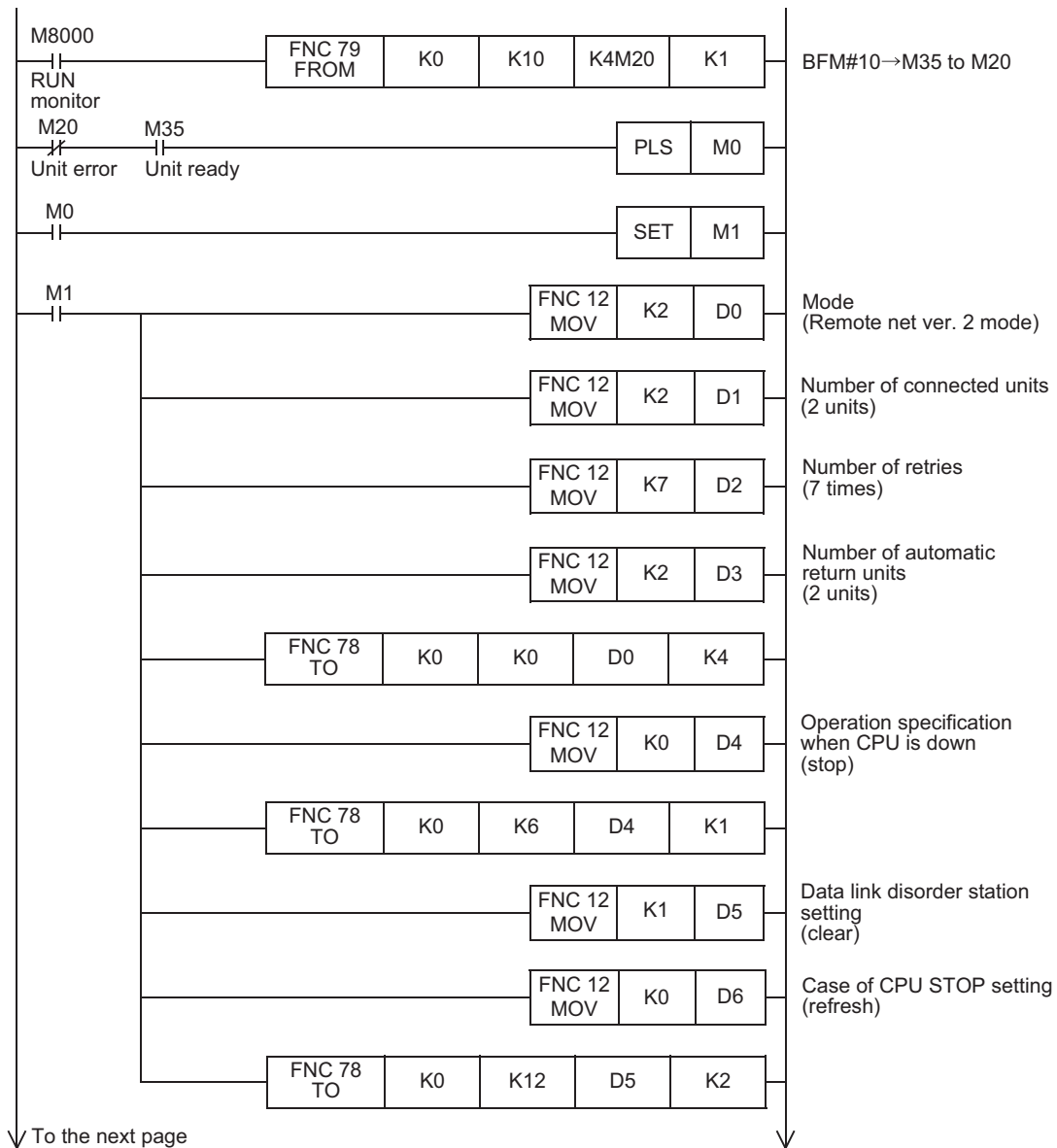

- 11 Programming
- 12 Remote I/O Communication Example
- 13 Remote Device Communication Example
- 14 Int. Device Communication Example
- 15 Compound Sys. Communication Example
- 16 Troubleshooting
- A Version Information
- B Setting Sheet
- C Differences with FX2N-16CCL-M

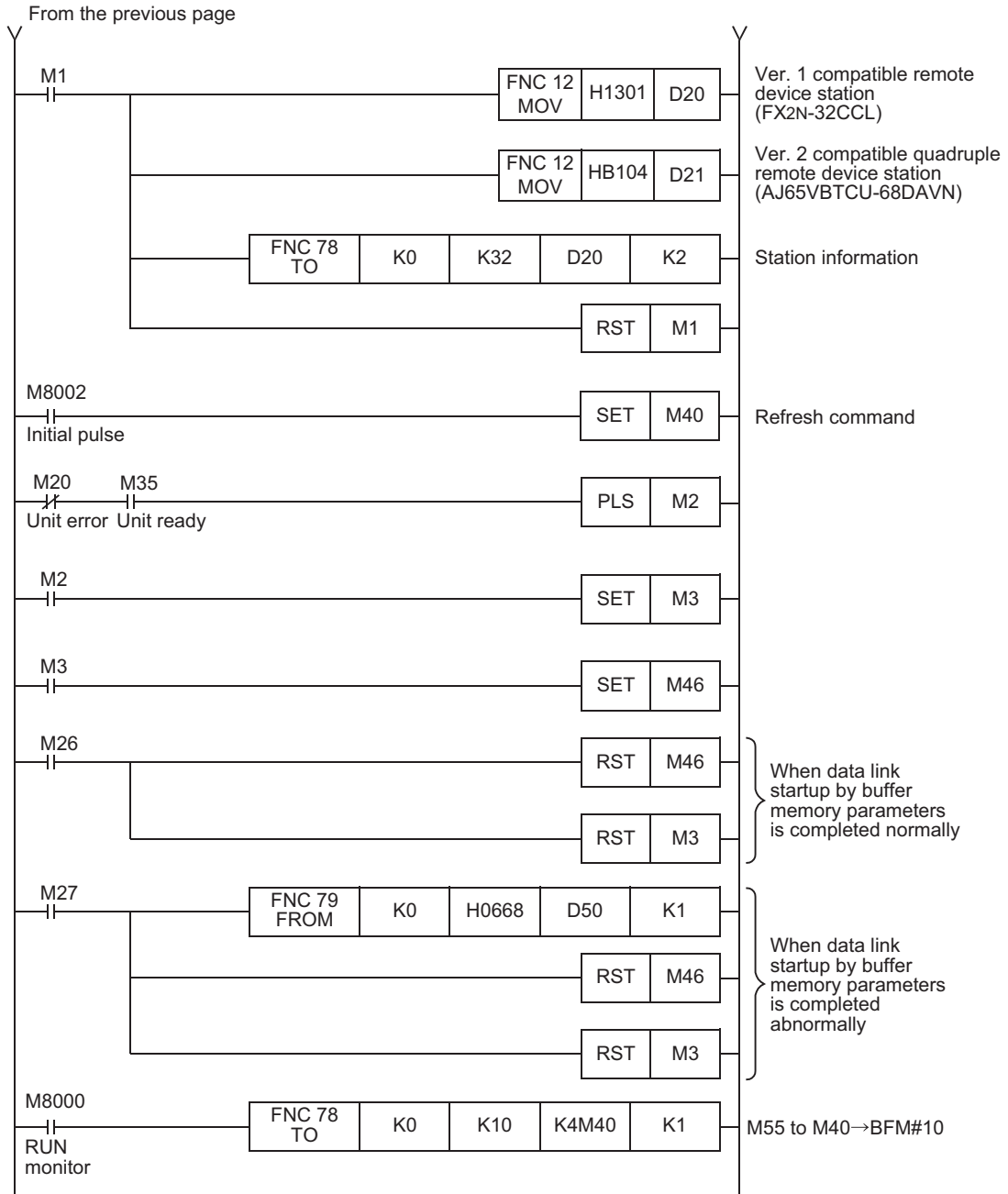

13.2.5 Creating a program for communication

This Subsection describes a program to control remote device stations.

- The relationship among the PLC, the master station buffer memory and the remote device stations.
 - Remote input (RX) and remote output (RY)

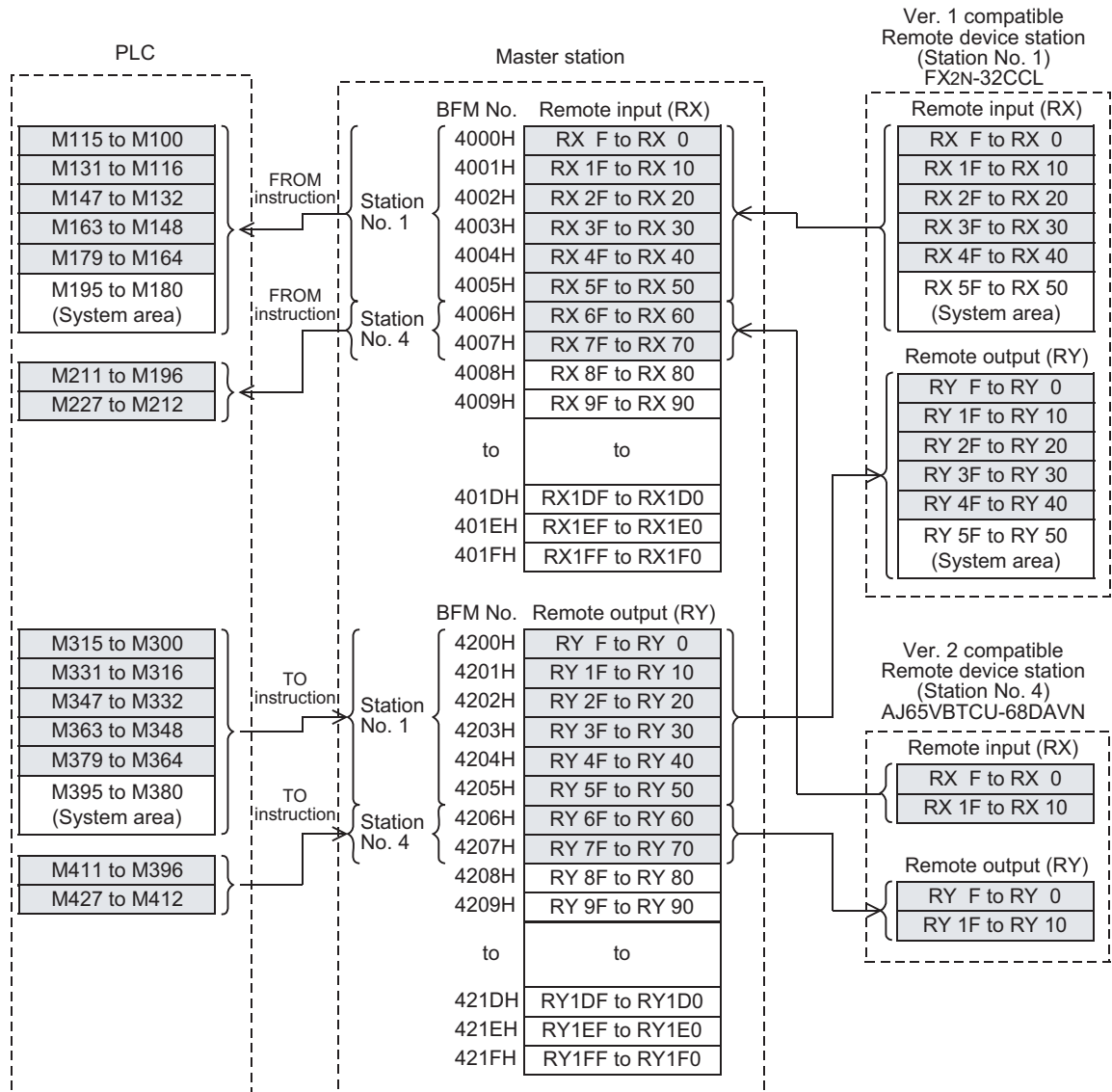

11	Programming
12	Remote I/O Communication Example
13	Remote Device Communication Example
14	Int. Device Communication Example
15	Compound Sys. Communication Example
16	Troubleshooting
A	Version Information
B	Setting Sheet
C	Differences with FX2N-16CCL-M

- Remote register (RWw, RWr)

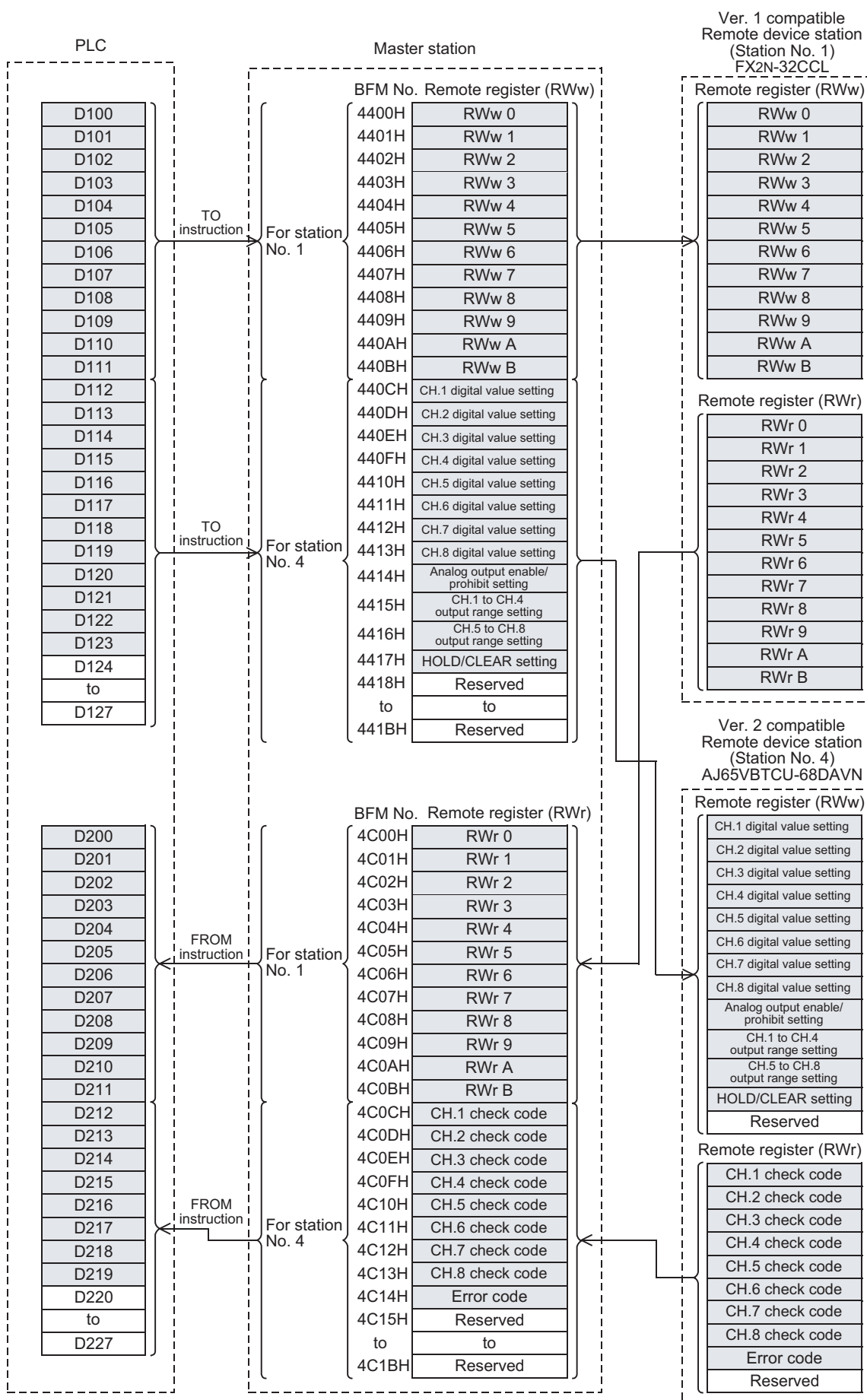

- Program to control remote device stations

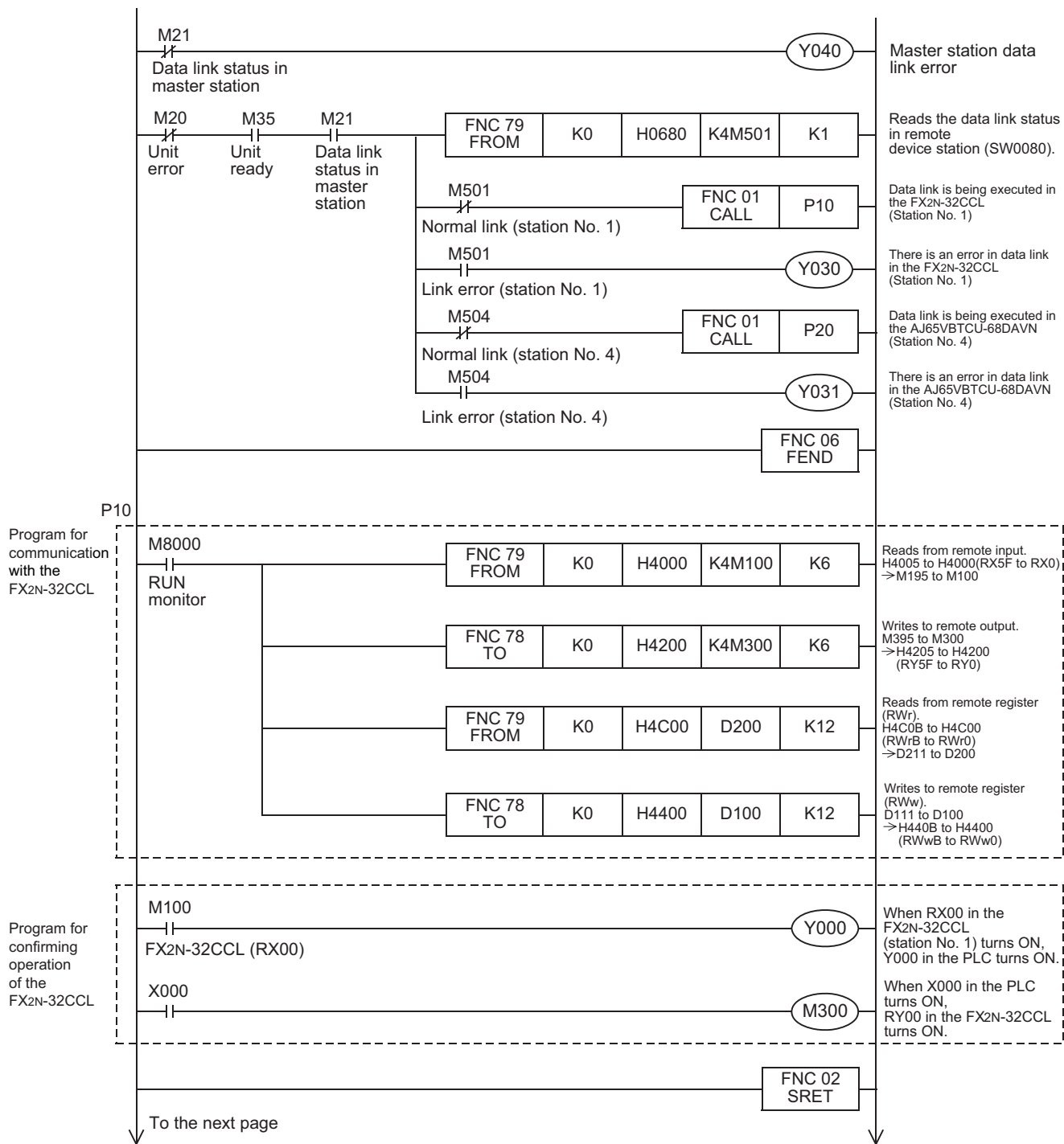

To the next page

11	Programming
12	Remote I/O Communication Example
13	Remote Device Communication Example
14	Int. Device Communication Example
15	Compound Sys. Communication Example
16	Troubleshooting
A	Version Information
B	Setting Sheet
C	Differences with FX2N-16CCL-M

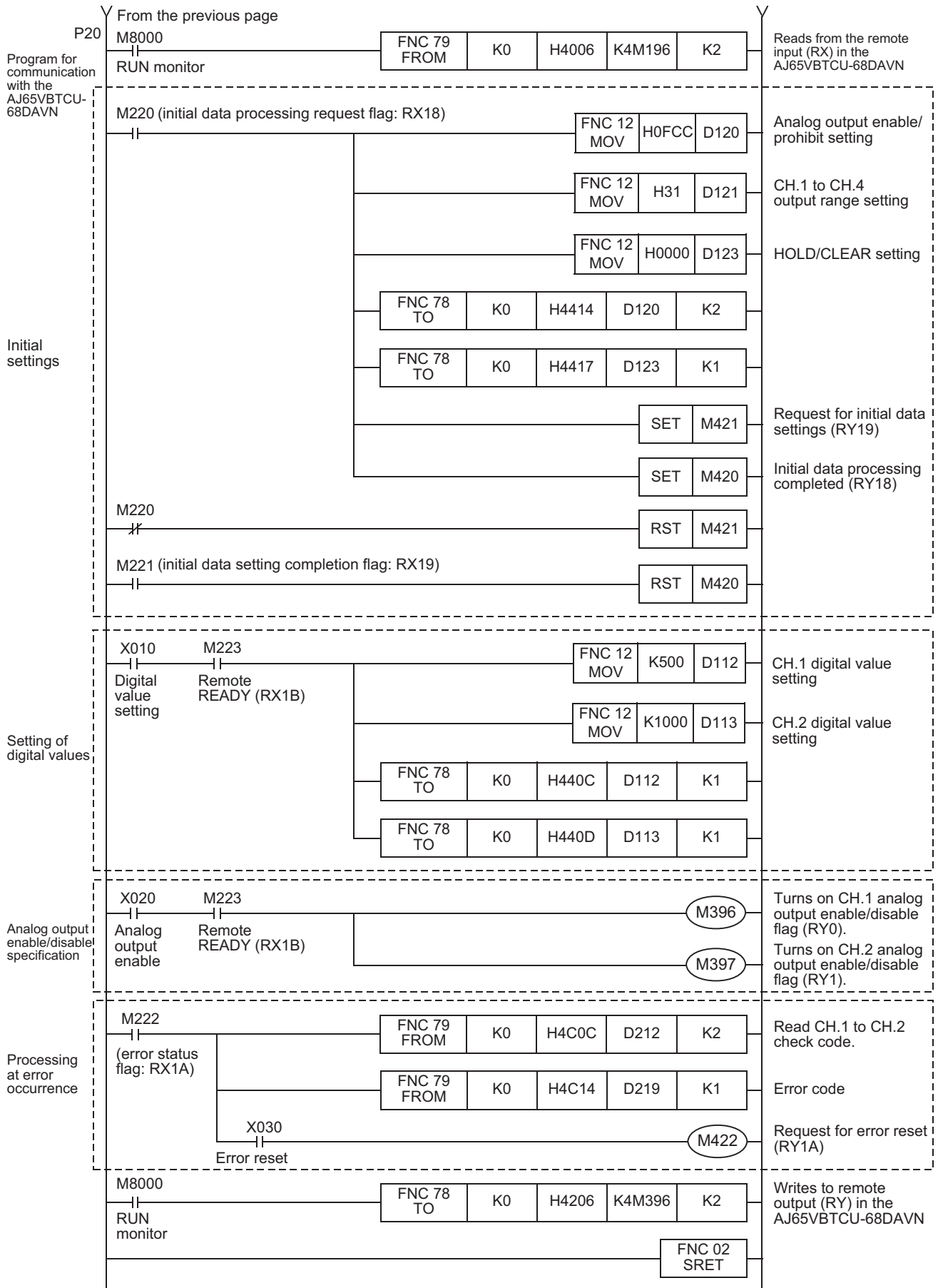

13.2.6 Execution of data link

Turn on the power of the remote device stations first, turn on the power of the master station, then start the data link.

13.2.7 Confirmation of operation by LED indication

The figures below show the LED indication status in the master station and the remote device stations while the data link is normally proceeding.

- LED indication in the master station

Make sure that the LED indication status is as shown below.

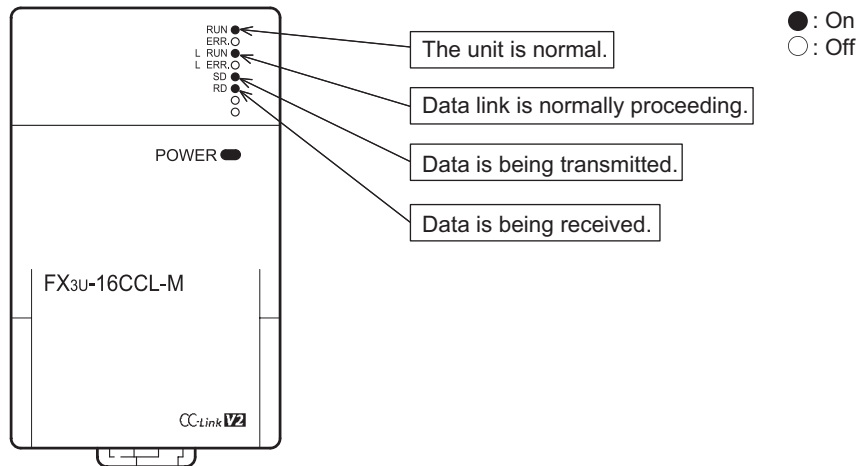

- LED indication in the remote device station

Make sure that the LED indication status is as shown below.

- FX2N-32CCL

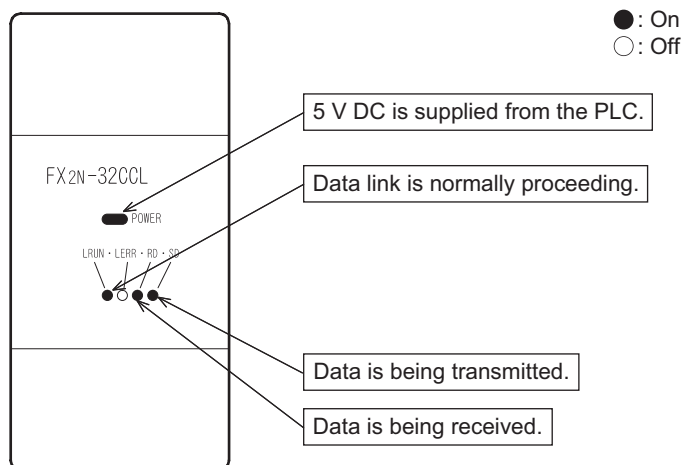

- AJ65VBTCU-68DAVN

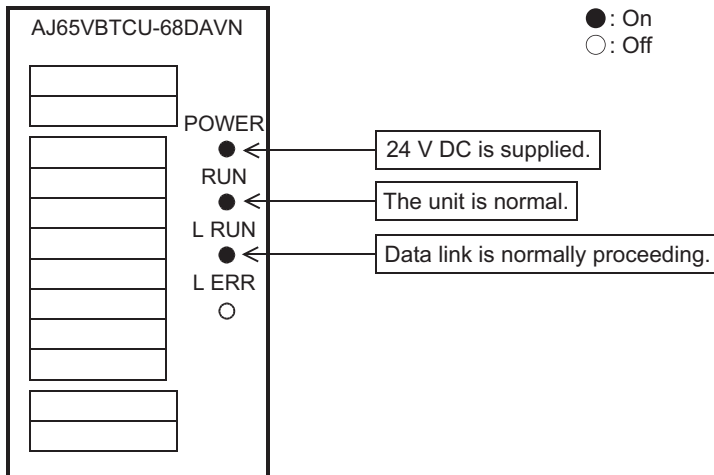

13.2.8 Confirmation of operation by program

Using a sequence program, make sure that data link is normally proceeding.

- 1) When X000 in the master station PLC turns ON, RY00 in the FX2N-32CCL (station No. 1) turns ON.
- 2) When RX00 in the FX2N-32CCL (station No. 1) turns ON, Y000 (M196) in the master station PLC turns ON
- 3) Set digital values to the AJ65VBTCU-68DAVN, and confirm that the voltages converted from digital to analog are output..

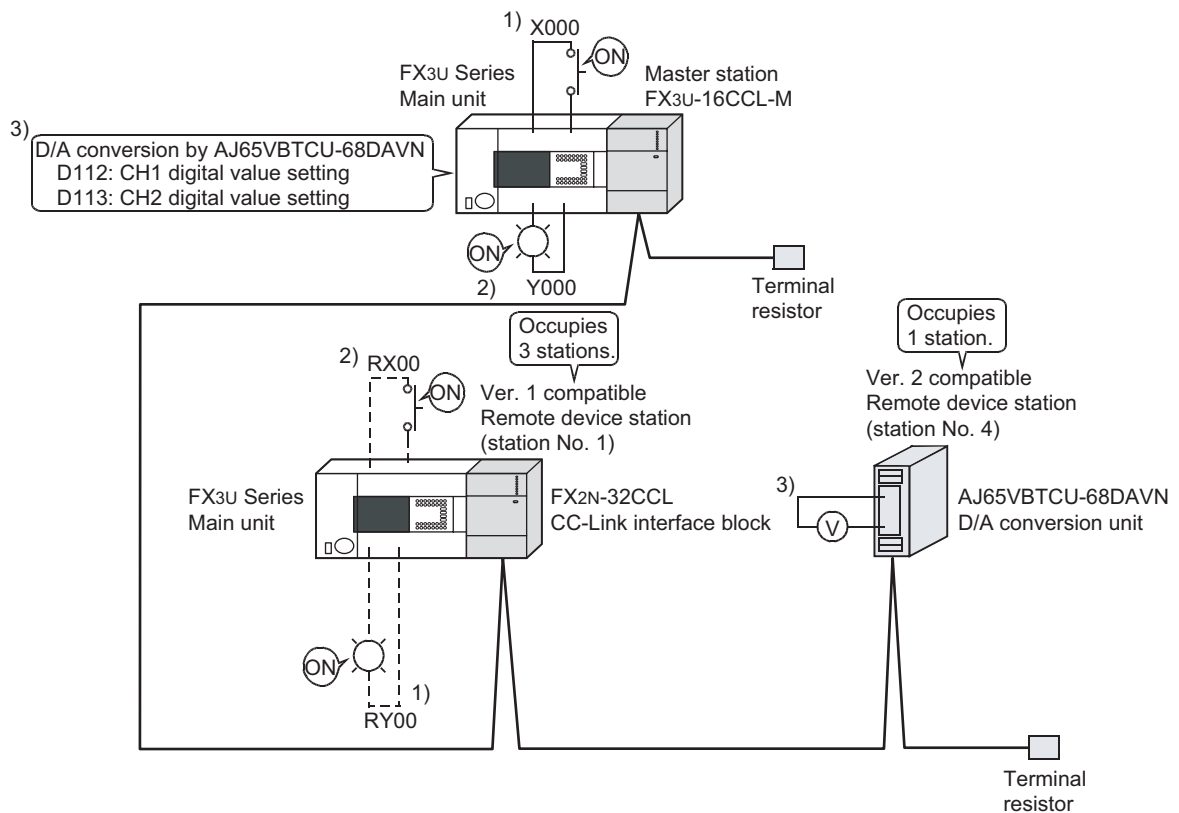

Caution

A program for communication is required also in the FX3U Series main unit connected to the FX2N-32CCL.

13.3 When Remote Net Additional Mode is Used

13.3.1 System configuration

It is supposed that one ver.1 compatible remote device station and one ver.2 compatible remote device station are connected in the system.

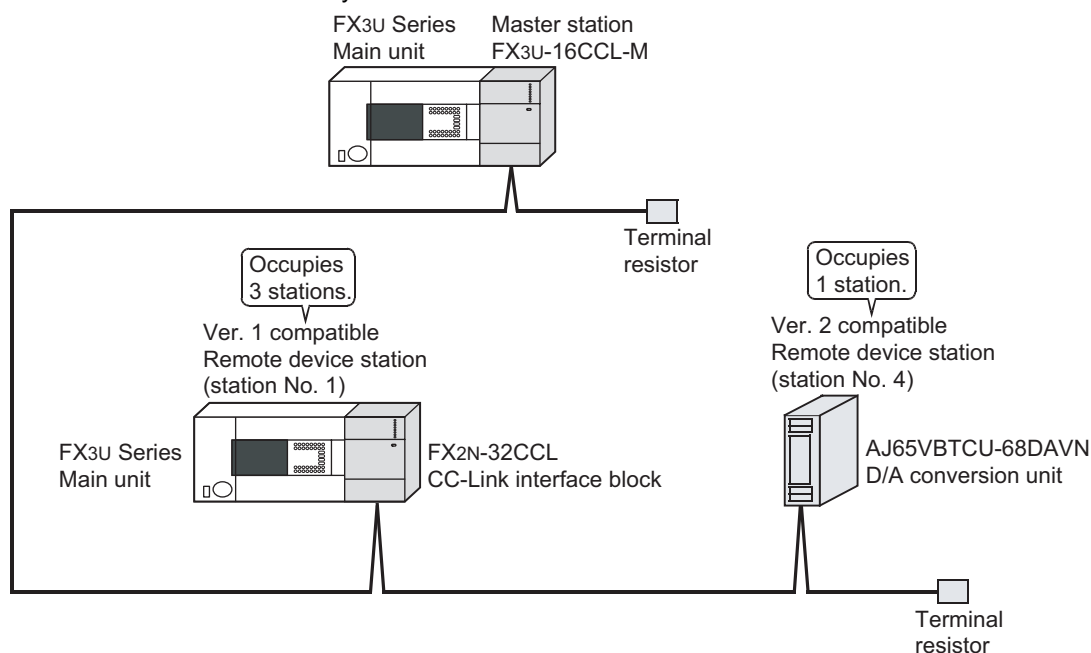

13.3.2 Setting of master station

The figure below shows the setting of the switches in the master station.

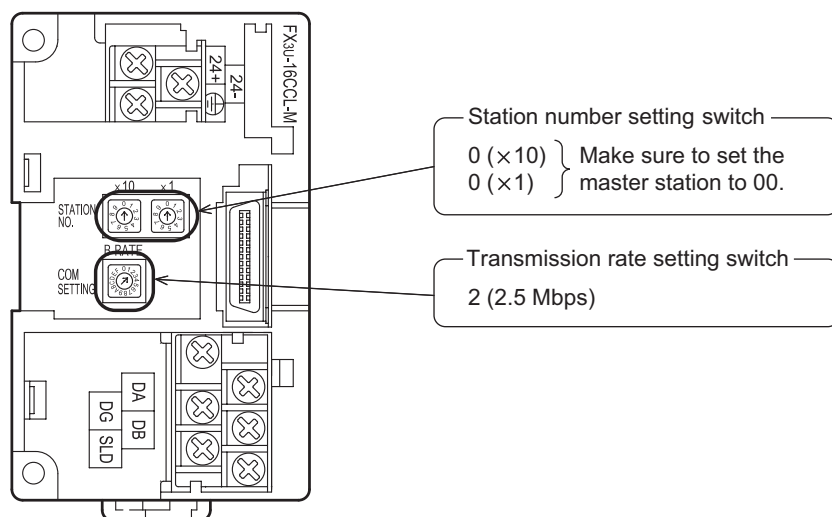

11

Programming

12

Remote I/O
Communication
Example

13

Remote Device
Communication
Example

14

Int. Device
Communication
Example

15

Compound Sys.
Communication
Example

16

Troubleshooting

A

Version
Information

B

Setting Sheet

C

Differences with
FX2N-16CCL-M

13.3.3 Setting of remote device station

The figure below shows the setting of the switches in the remote device station.

- FX2N-32CCL

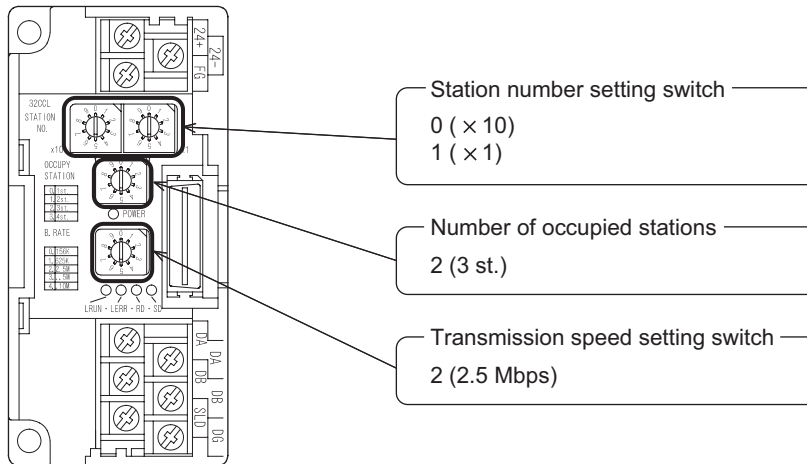

- AJ65VBTCU-68DAVN

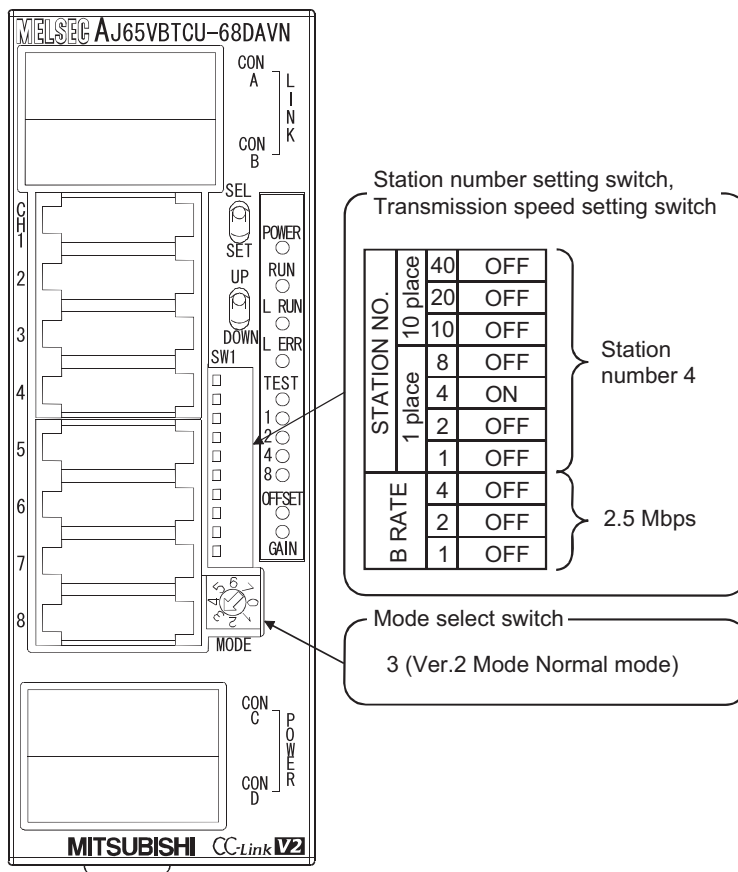

13.3.4 Setting of parameters

This Subsection describes parameter setup for performing a data link. This subsection describes parameter setup for performing data link using a sequence program. Refer to Section 8.5 for the setting method using network parameters. The program for parameters shown below is not required when parameters are set using network parameters.

1. Program for parameters

In the program below, data link automatically starts when the PLC starts to run.

Caution

The auxiliary relays in the non-keep area must be used as auxiliary relays (M) for parameter setting programs.

→ For the precautions in programming, refer to Section 11.1.

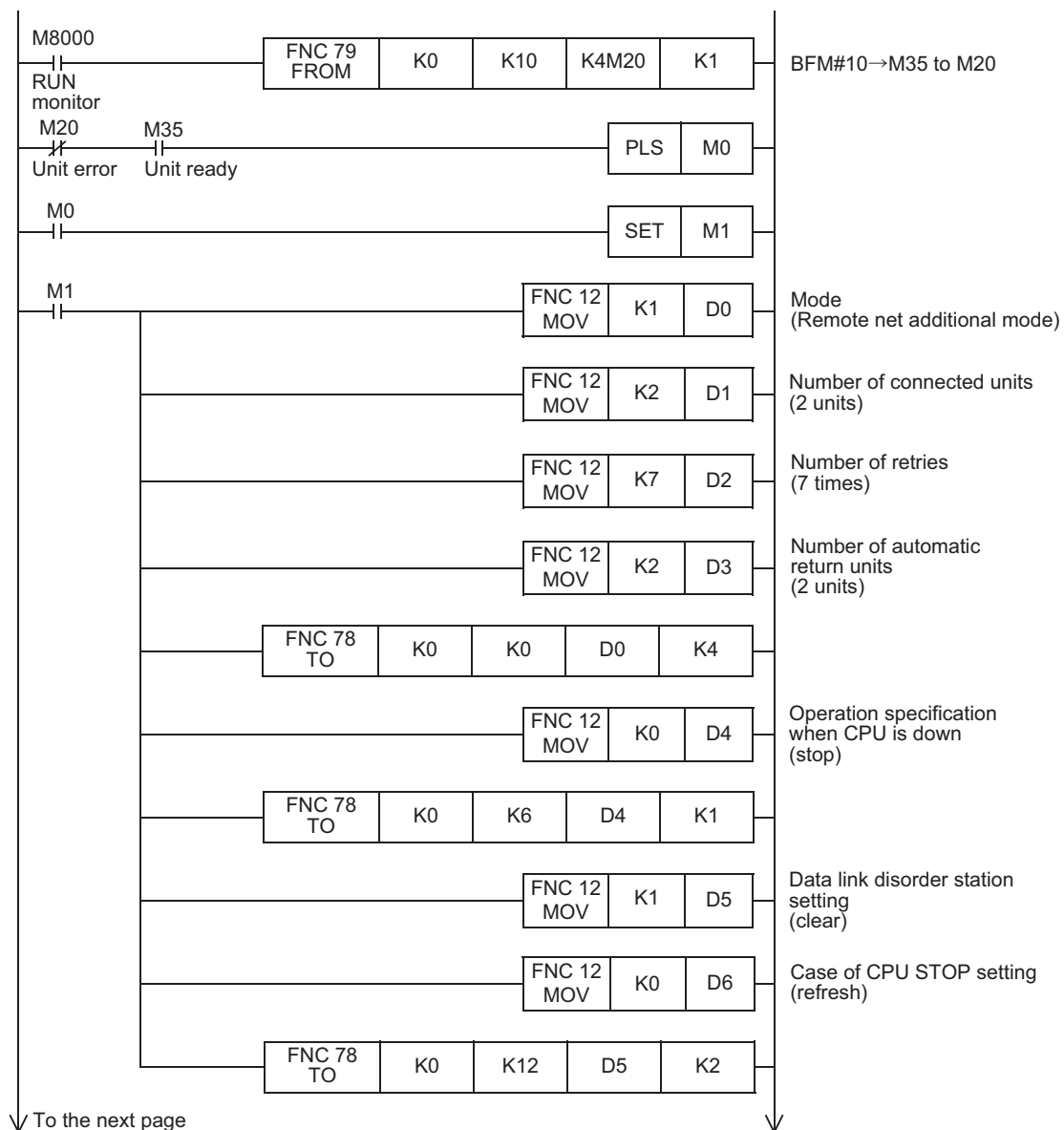

11

Programming

12

Remote I/O
Communication
Example

13

Remote Device
Communication
Example

14

Int. Device
Communication
Example

15

Compound Sys.
Communication
Example

16

Troubleshooting

A

Version
Information

B

Setting Sheet

C

Differences with
FX2N-16CCL-M

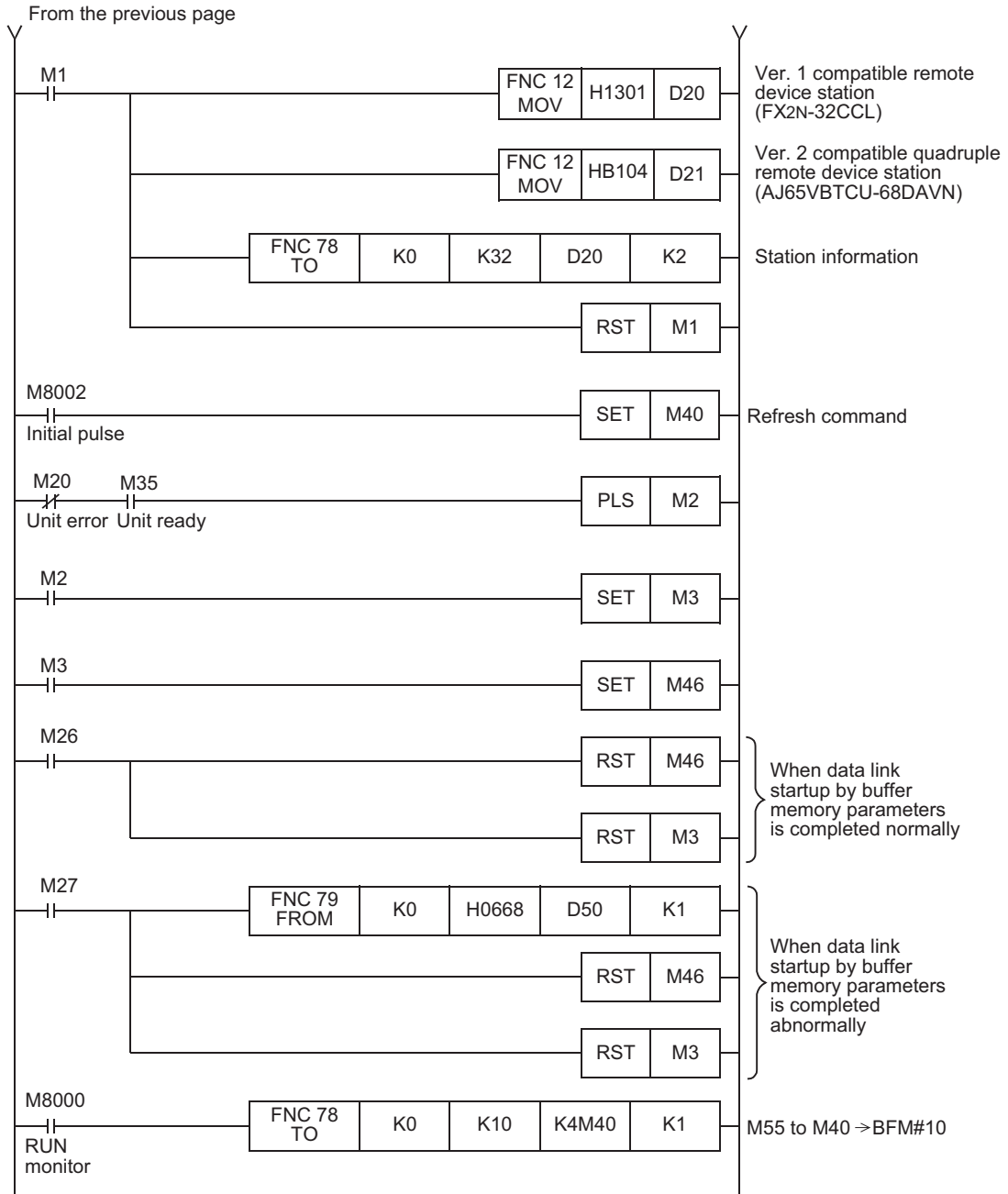

13.3.5 Creating a program for communication

This Subsection describes a program to control remote device stations.

- The relationship among the PLC, the master station buffer memory and the remote device stations.
 - Remote input (RX) and remote output (RY)

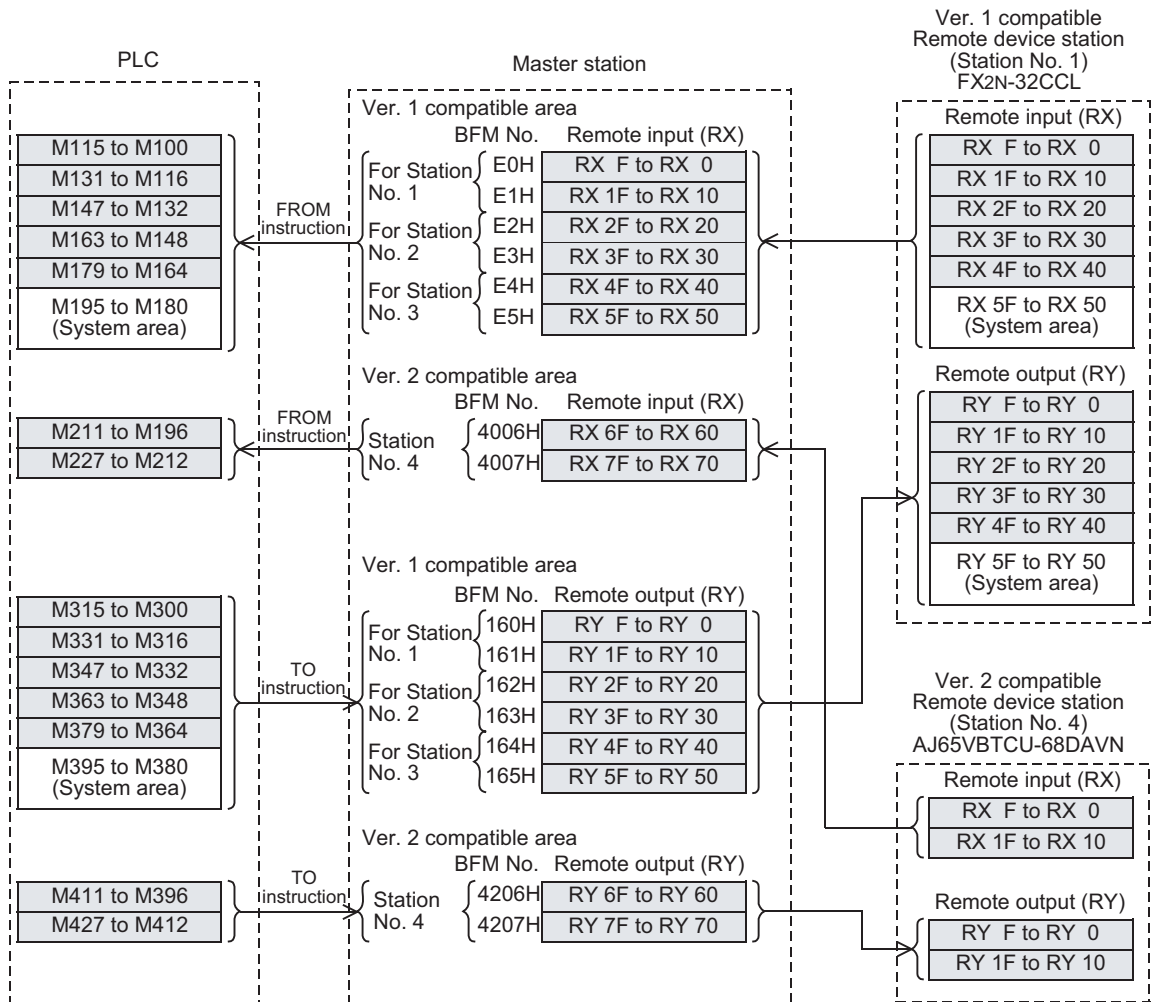

- Remote register (RWw, RWr)

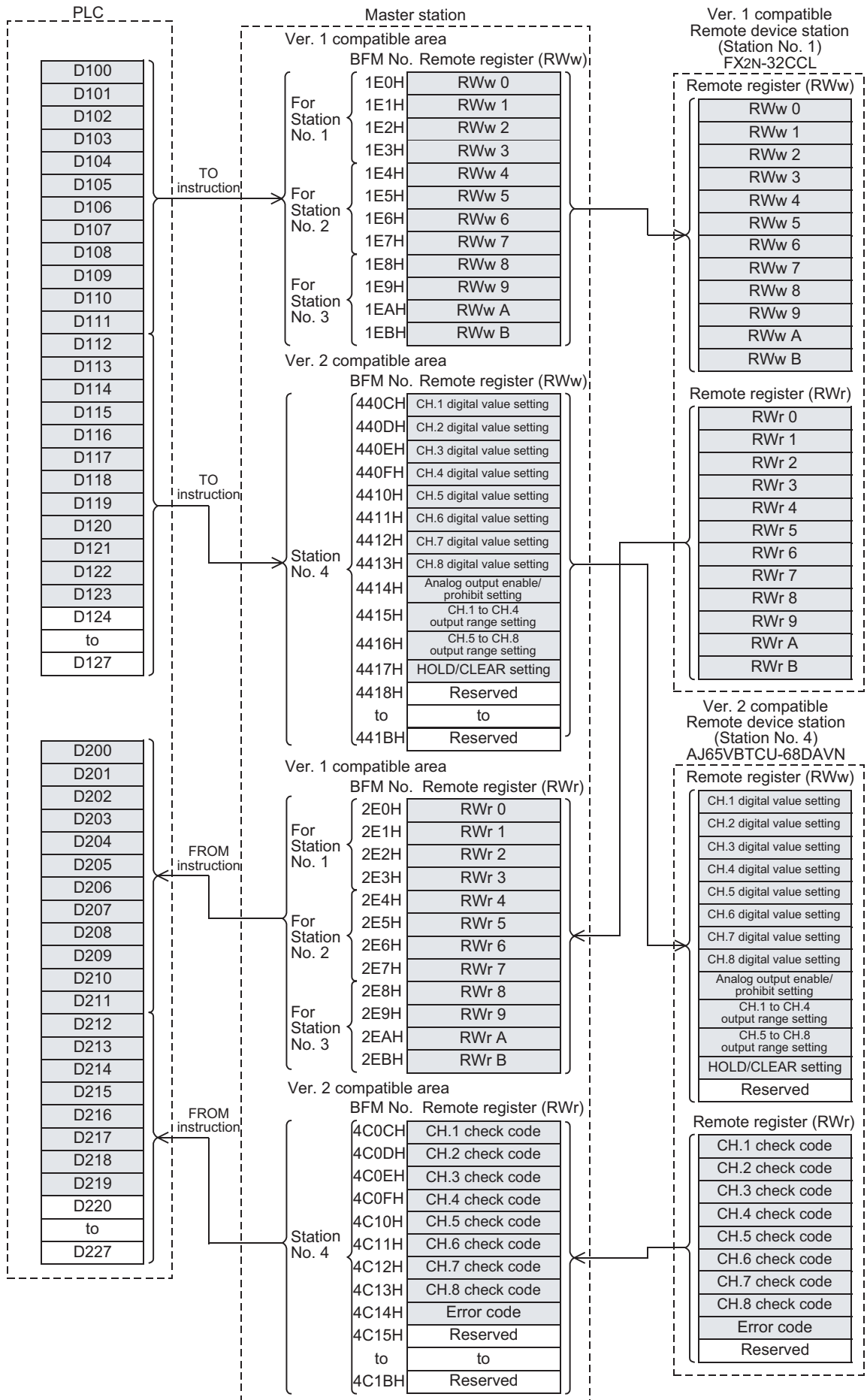

- Program to control remote device stations

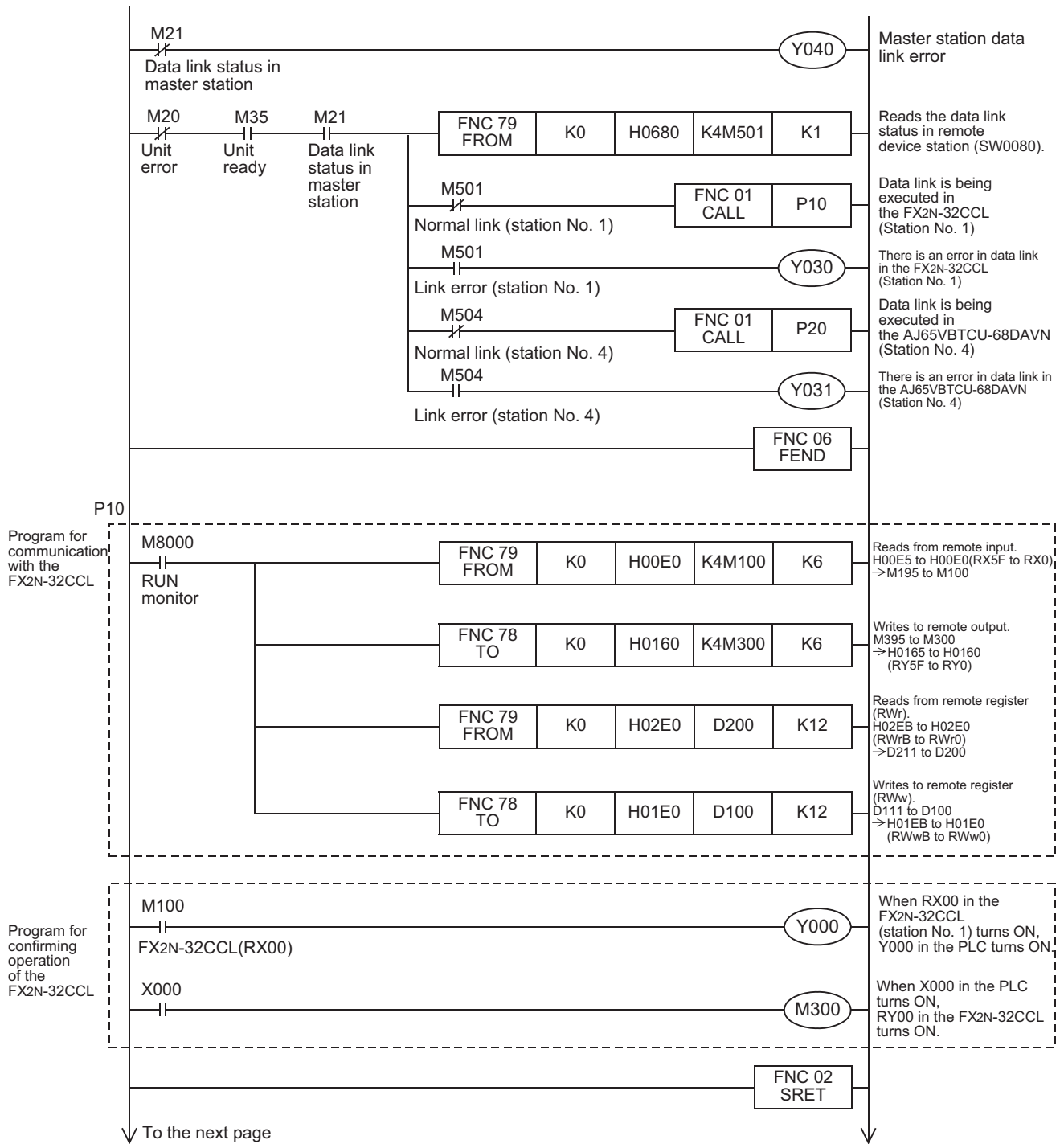

11	Programming
12	Remote I/O Communication Example
13	Remote Device Communication Example
14	Int. Device Communication Example
15	Compound Sys. Communication Example
16	Troubleshooting
A	Version Information
B	Setting Sheet
C	Differences with FX2N-16CCL-M

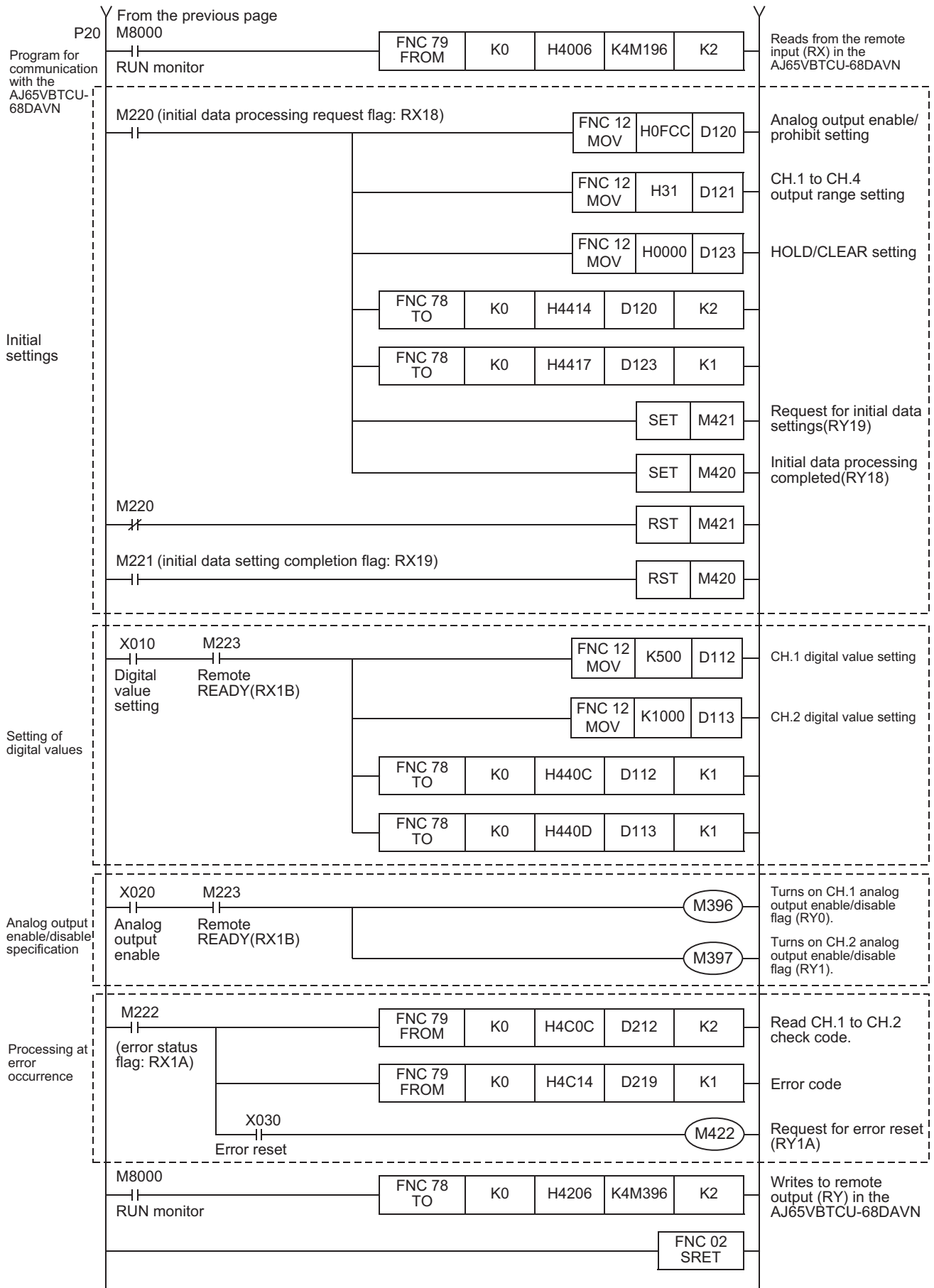

13.3.6 Execution of data link

Turn on the power of the remote device stations first, turn on the power of the master station, then start the data link.

13.3.7 Confirmation of operation by LED indication

The figures below show the LED indication status in the master station and the remote device stations while the data link is normally proceeding.

- LED indication in the master station
Make sure that the LED indication status is as shown below.

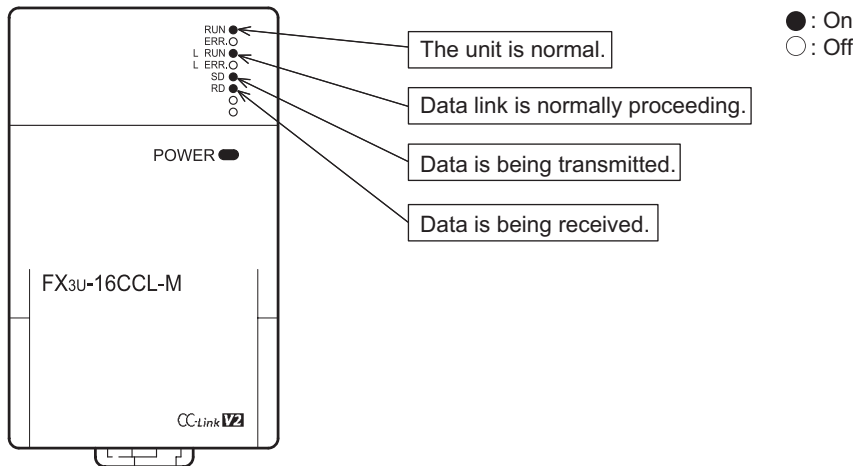

- LED indication in the remote device station
Make sure that the LED indication status is as shown below.
- FX2N-32CCL

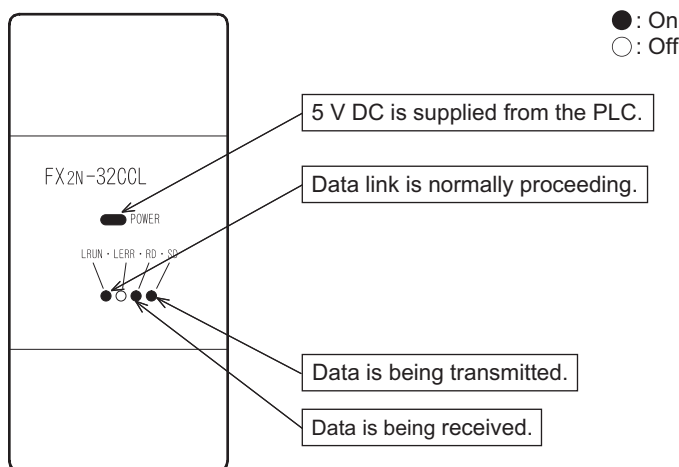

- AJ65VBTCU-68DAVN

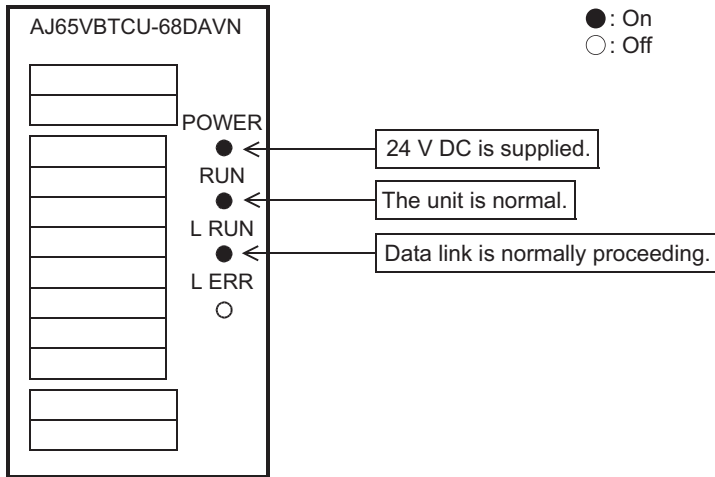

13.3.8 Confirmation of operation by program

Using a sequence program, make sure that data link is normally proceeding.

- 1) When X000 in the master station PLC turns ON, RY00 in the FX2N-32CCL (station No. 1) turns ON.
- 2) When RX00 in the FX2N-32CCL (station No. 1) turns ON, Y000 (M196) in the master station PLC turns ON
- 3) Set digital values to the AJ65VBTCU-68DAVN, and confirm that the voltages converted from digital to analog are output..

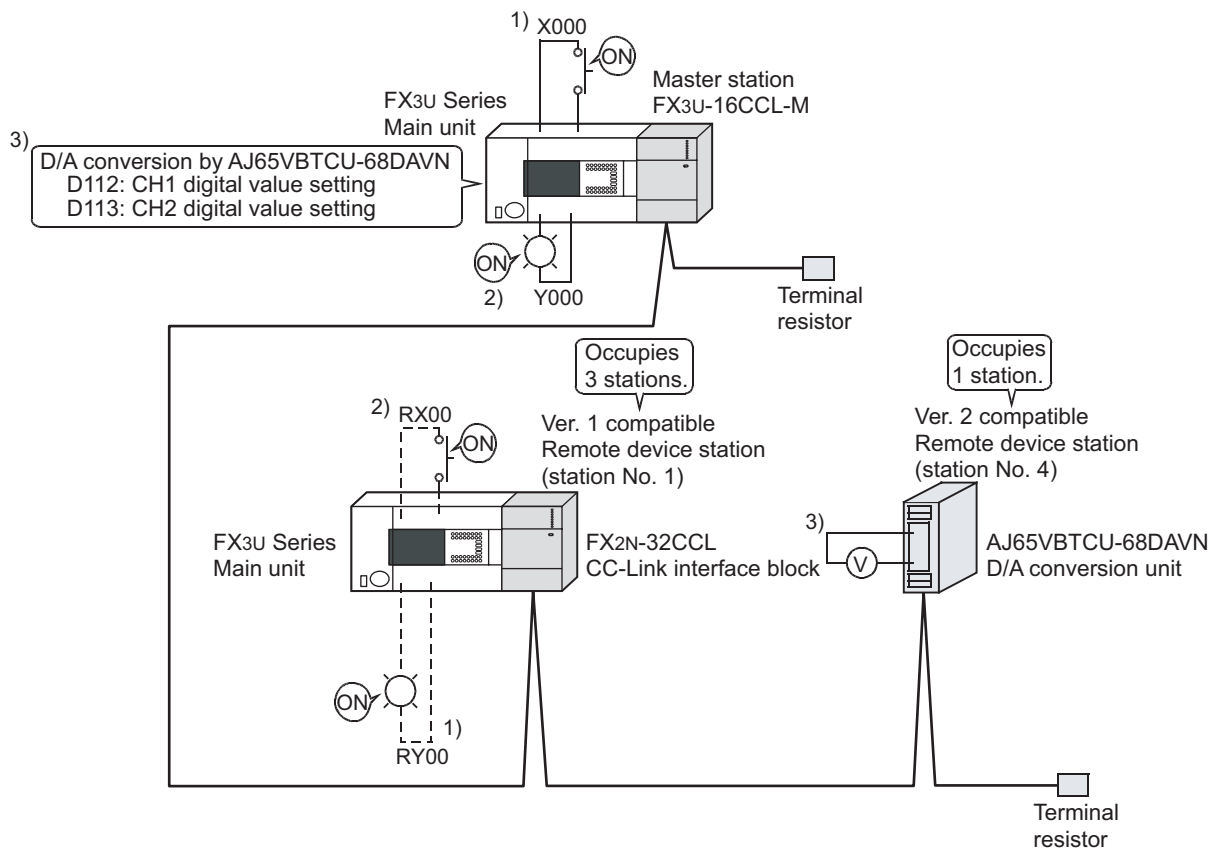

Caution

A program for communication is required also in the FX3U Series main unit connected to the FX2N-32CCL.

14. Example of Communication between Master Station and Intelligent Device Stations

This chapter explains the procedures from unit settings to parameter settings, programming, and finally operation check using a system configuration example.

The example which uses a FROM/TO instructions explains read/write of a buffer memory. For the other methods, refer to the programming manual.

An intelligent device station becomes the system configuration which uses FX3U-64CCL.

For details on the FX3U-64CCL, refer to the FX3U-64CCL User's Manual.

14.1 When Remote Net Ver. 1 Mode is Used

14.1.1 System configuration

It is supposed that two intelligent device stations (FX3U-64CCL) are connected in the system.

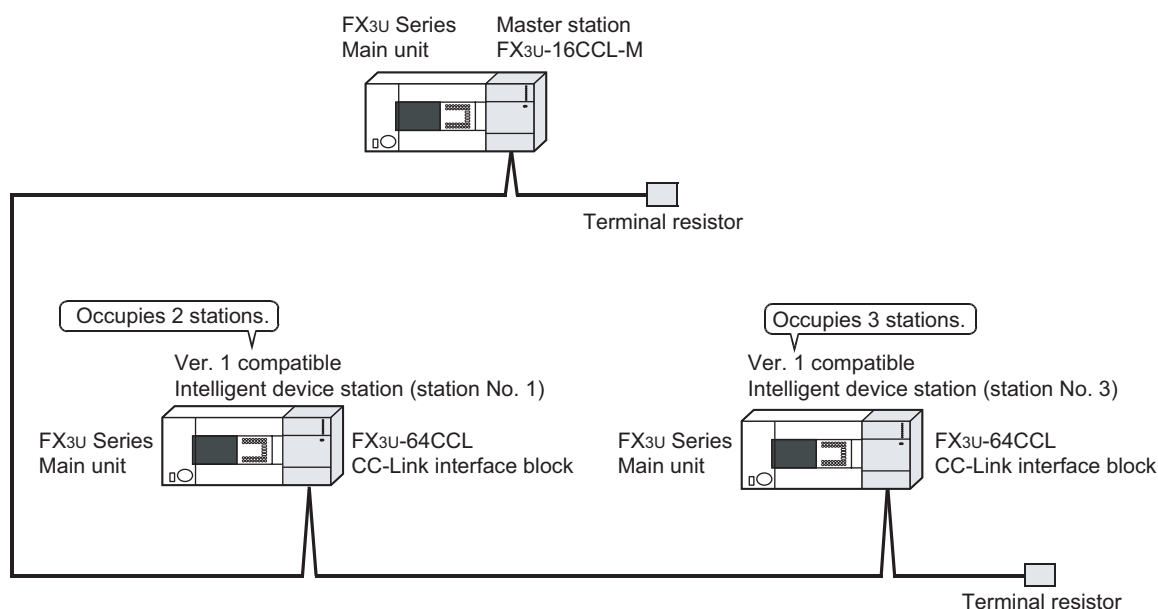

14.1.2 Setting of master station

The figure below shows the setting of the switches in the master station.

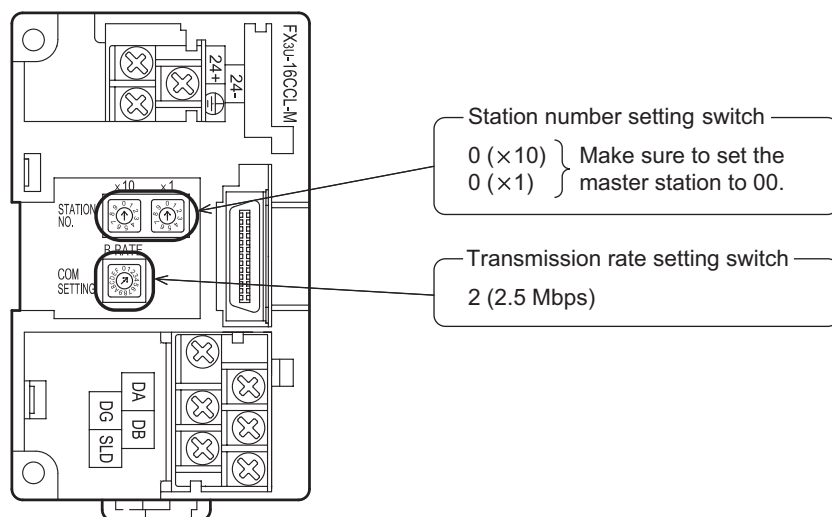

- 11 Programming
- 12 Remote I/O Communication Example
- 13 Remote Device Communication Example
- 14 Int. Device Communication Example
- 15 Compound Sys. Communication Example
- 16 Troubleshooting
- A Version Information
- B Setting Sheet
- C Differences with FX2N-16CCL-M

14.1.3 Setting of intelligent device station

The figure below shows the setting of the switches in the intelligent device station (FX3U-64CCL).

- FX3U-64CCL (Station No. 1)

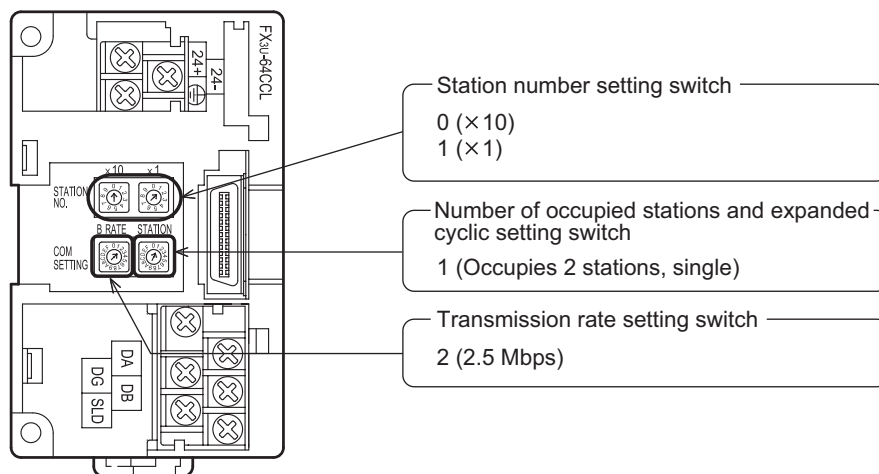

- FX3U-64CCL (Station No. 4)

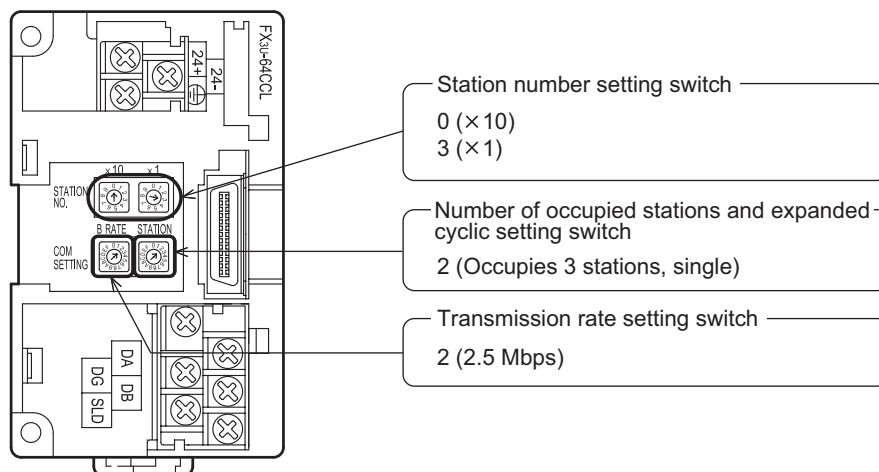

14.1.4 Setting of parameters

This Subsection describes parameter setup for performing a data link. This subsection describes parameter setup for performing data link using a sequence program. Refer to Section 8.5 for the setting method using network parameters. The program for parameters shown below is not required when parameters are set using network parameters.

1. Program for parameters

In the program below, data link automatically starts when the PLC starts to run.

Caution

The auxiliary relays in the non-keep area must be used as auxiliary relays (M) for parameter setting programs.

→ For the precautions in programming, refer to Section 11.1.

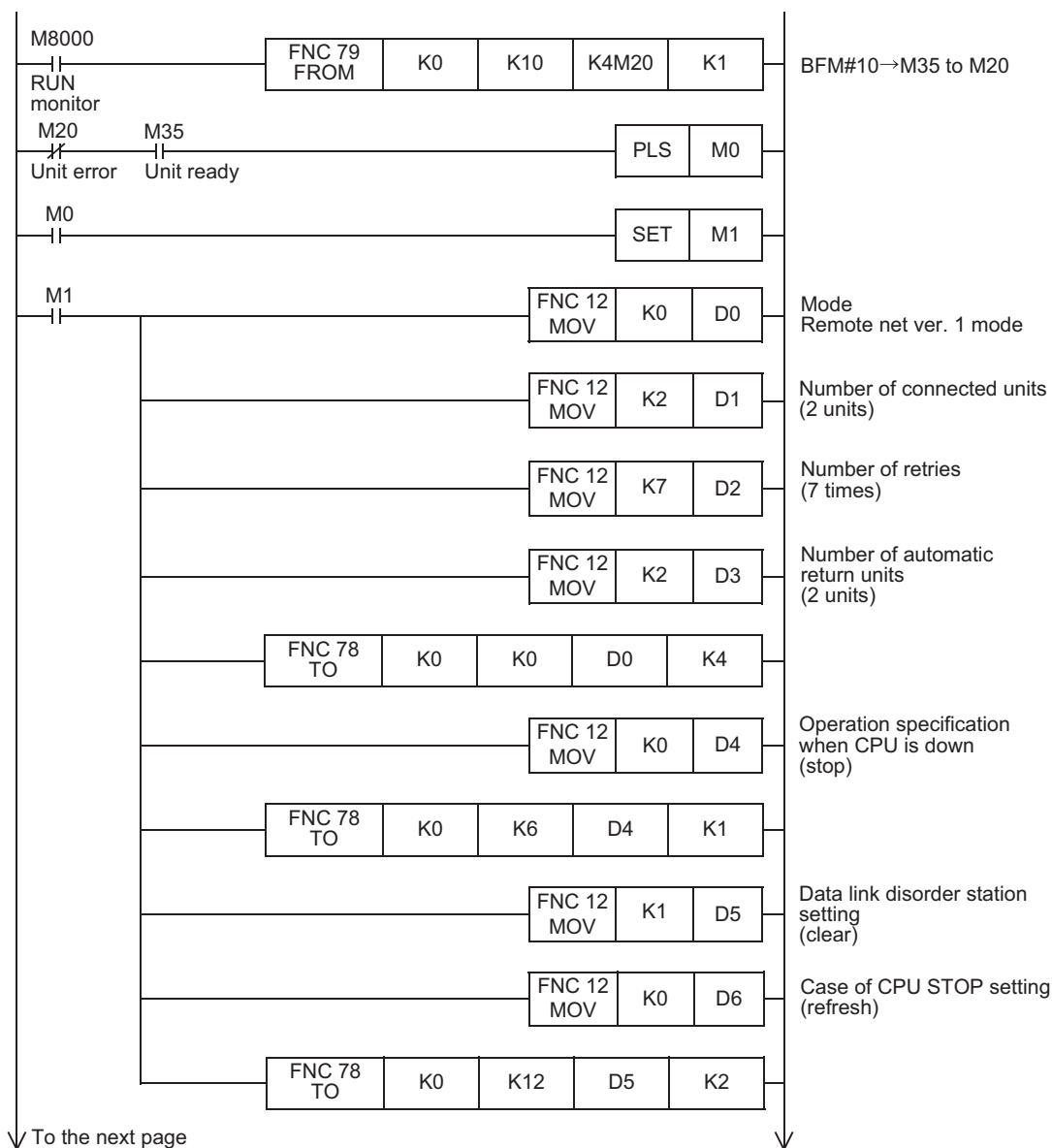

- 11 Programming
- 12 Remote I/O Communication Example
- 13 Remote Device Communication Example
- 14 Int. Device Communication Example
- 15 Compound Sys. Communication Example
- 16 Troubleshooting
- A Version Information
- B Setting Sheet
- C Differences with FX2N-16CCL-M

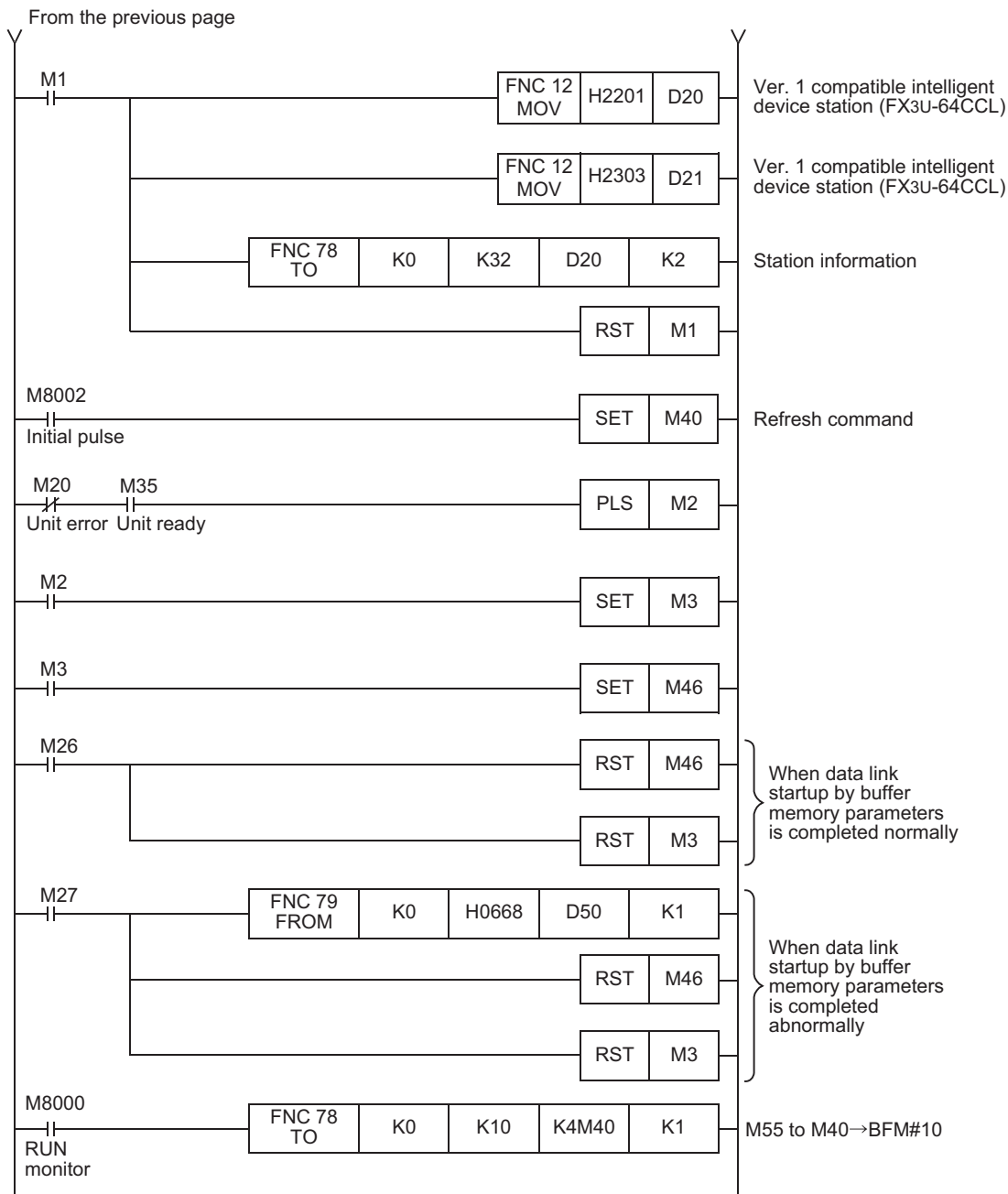

14.1.5 Creating a program for communication

This Subsection describes a program to control intelligent device stations (FX3U-64CCL).

- The relationship among the PLC, the master station buffer memory and the intelligent device stations.
 - Remote input (RX) and remote output (RY)

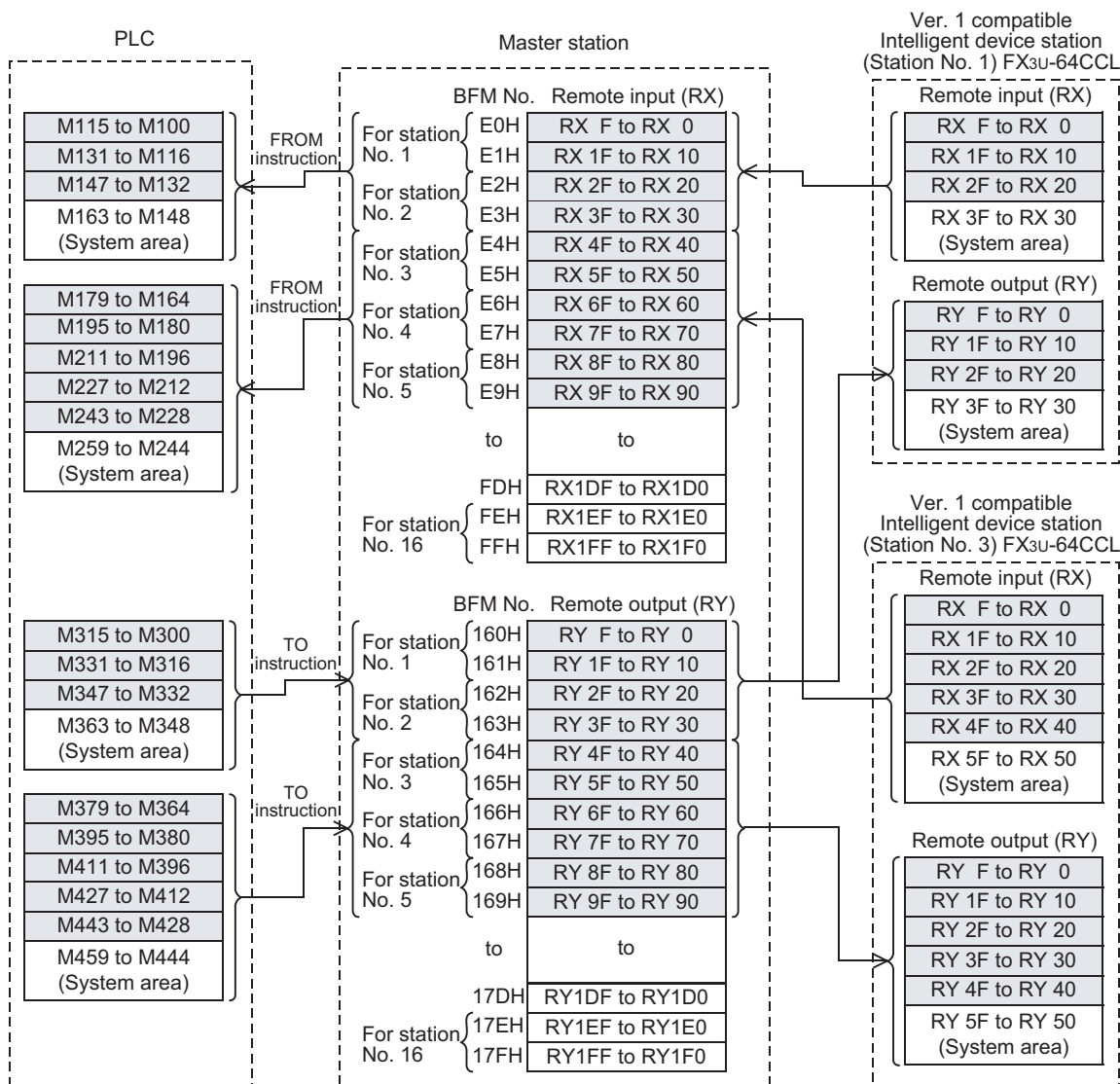

11	Programming
12	Remote I/O Communication Example
13	Remote Device Communication Example
14	Int. Device Communication Example
15	Compound Sys. Communication Example
16	Troubleshooting
A	Version Information
B	Setting Sheet
C	Differences with FX2N-16CCL-M

- Remote register (RWw, RWr)

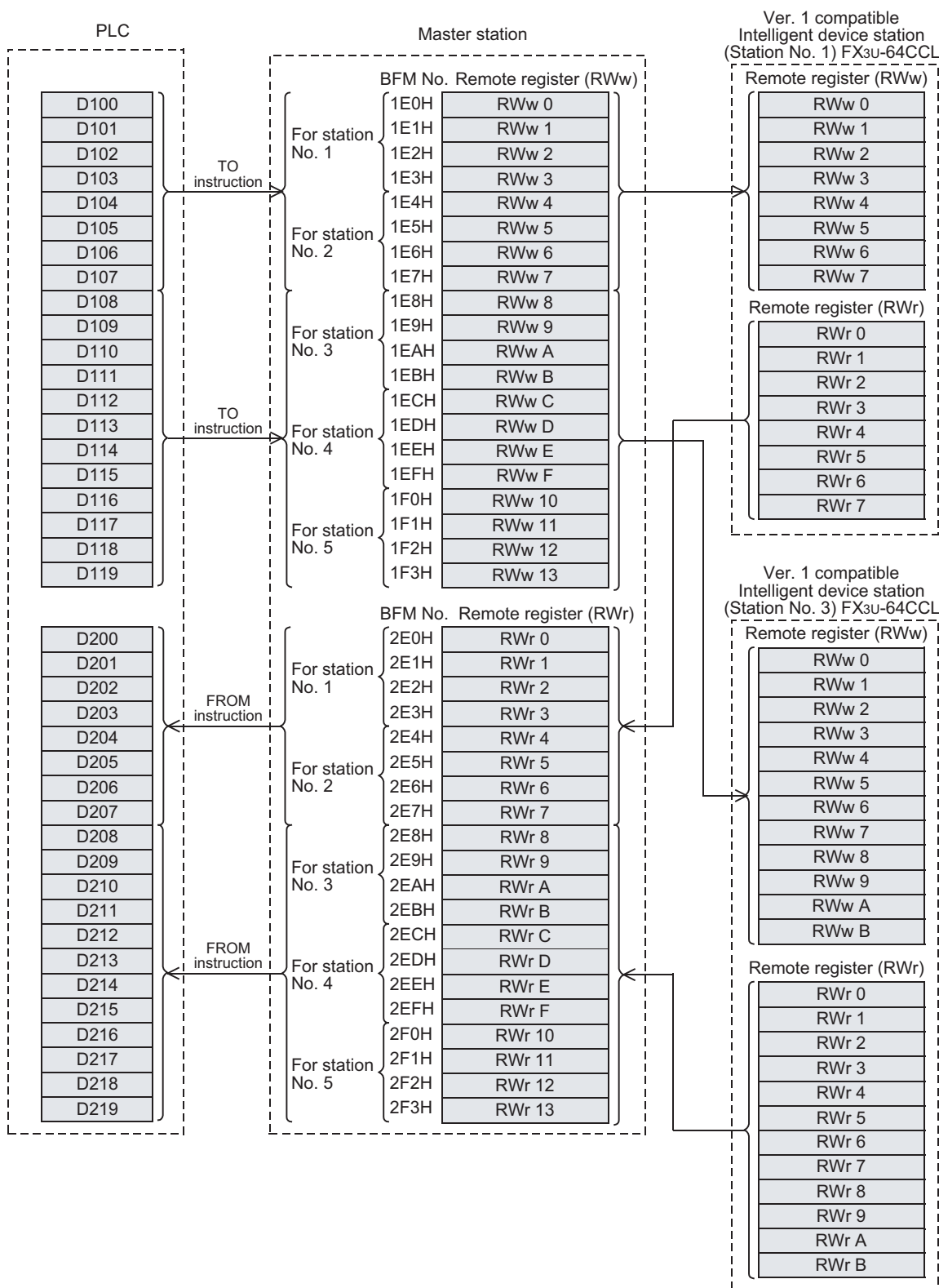

• Program to control intelligent device stations (FX3U-64CCL)

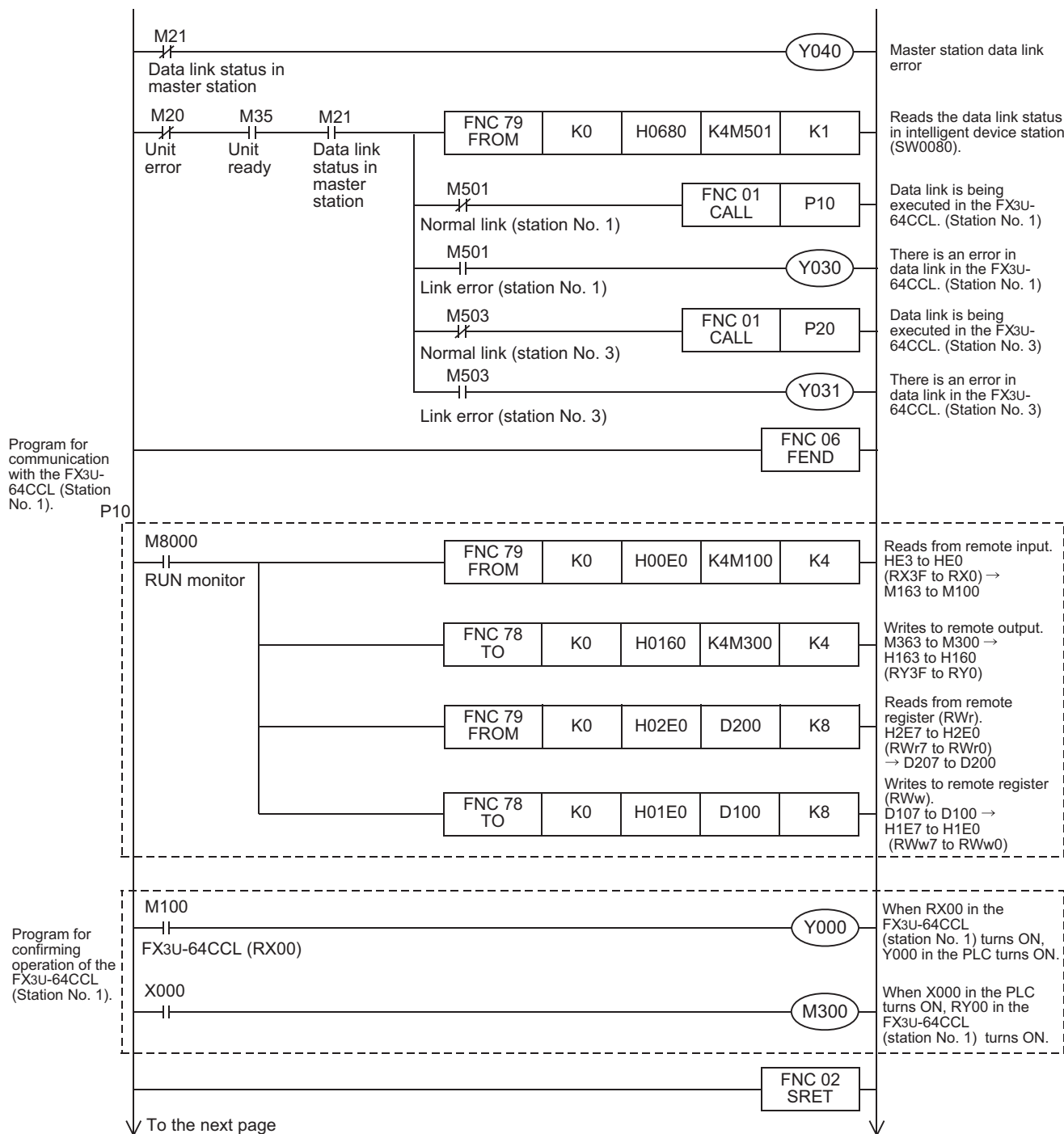

11	Programming
12	Remote I/O Communication Example
13	Remote Device Communication Example
14	Int. Device Communication Example
15	Compound Sys. Communication Example
16	Troubleshooting
A	Version Information
B	Setting Sheet
C	Differences with FX2N-16CCL-M

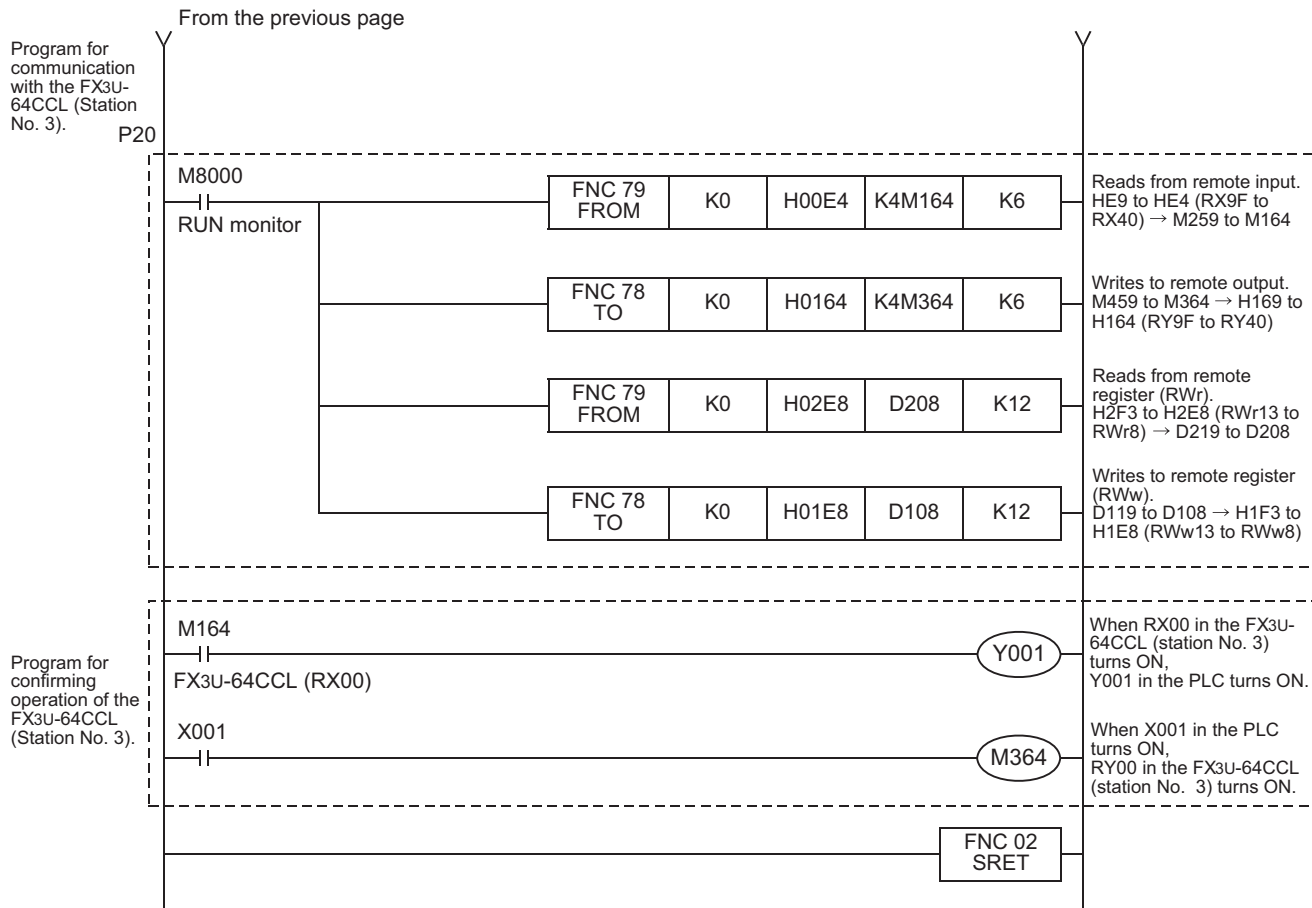

14.1.6 Execution of data link

Turn on the power of the intelligent device stations first, turn on the power of the master station, then start the data link.

14.1.7 Confirmation of operation by LED indication

The figures below show the LED indication status in the master station and the intelligent device stations while the data link is normally proceeding.

- LED indication in the master station
Make sure that the LED indication status is as shown below.

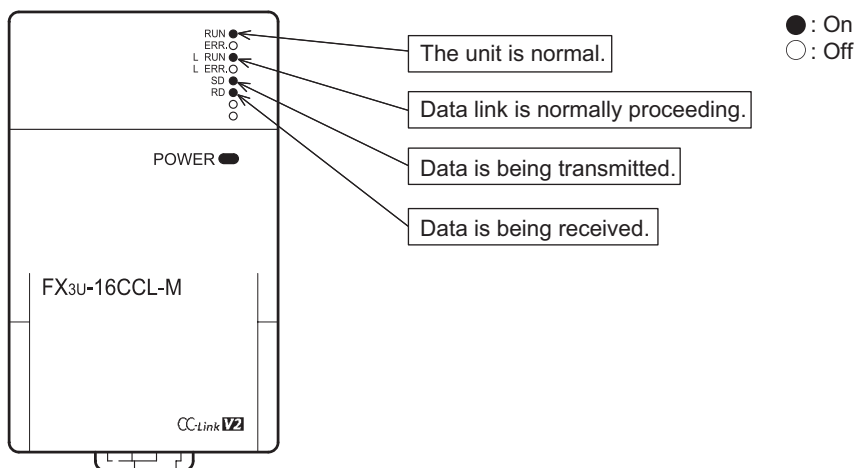

- LED indication in the intelligent device station (FX3U-64CCL)
Make sure that the LED indication status is as shown below.

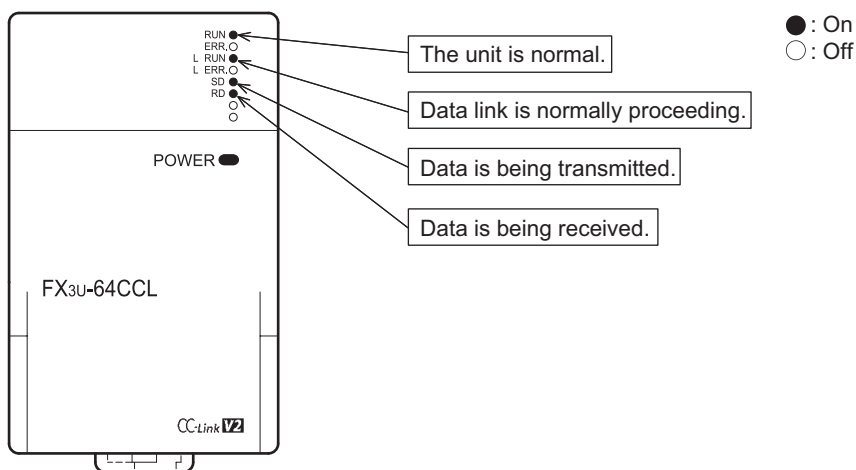

14.1.8 Confirmation of operation by program

Using a sequence program, make sure that data link is normally proceeding.

- 1) When X000 in the master station PLC turns ON, RY00 in the FX3U-64CCL (station No. 1) turns ON.
- 2) When RX00 in the FX3U-64CCL (station No. 1) turns ON, Y000 (M100) in the master station PLC turns ON.
- 3) When X001 in the master station PLC turns ON, RY40 in the FX3U-64CCL (station No. 3) turns ON.
- 4) When RX40 in the FX3U-64CCL (station No. 3) turns ON, Y001 (M164) in the master station PLC turns ON.

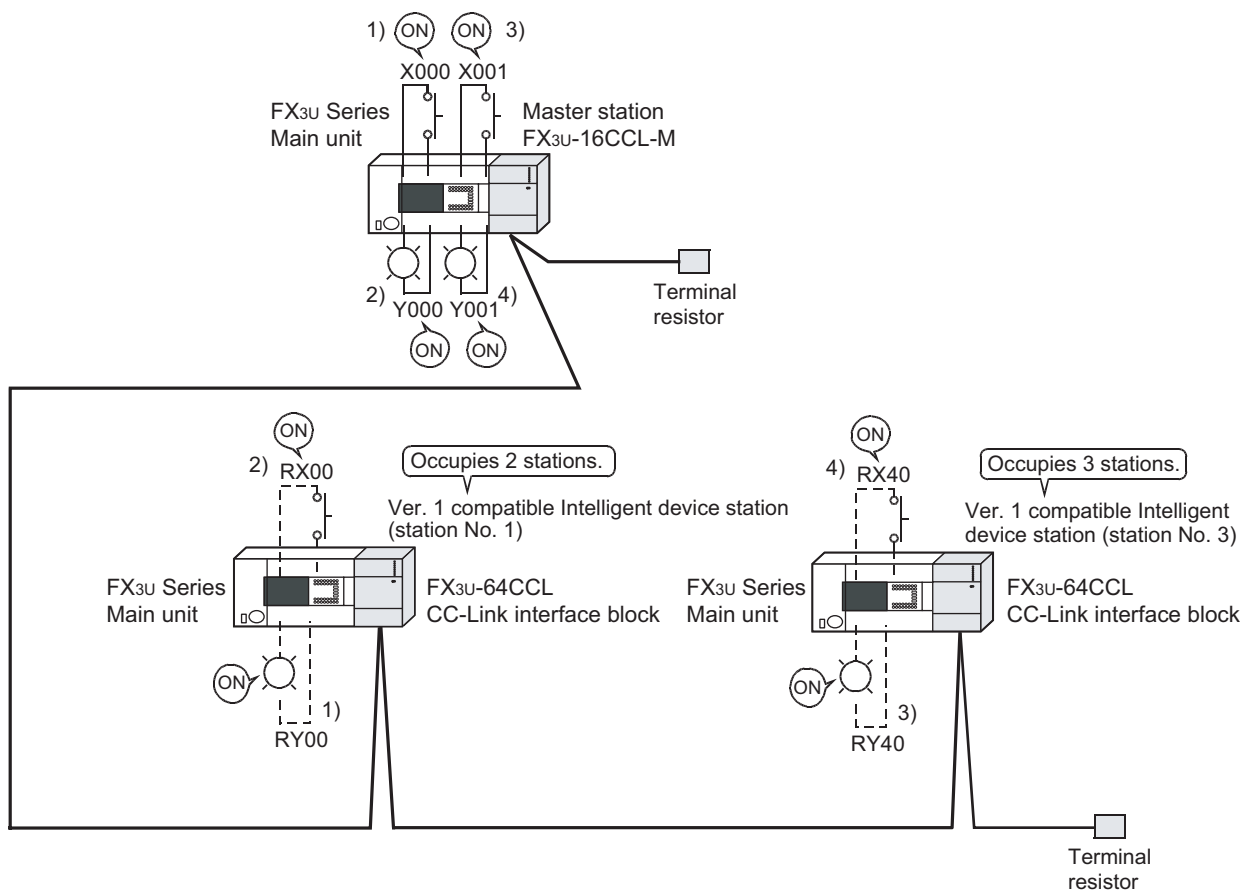

Caution

A program for communication is required also in the FX3U Series main unit connected to the FX3U-64CCL.

14.2 When Remote Net Ver. 2 Mode is Used

14.2.1 System configuration

It is supposed that one ver.1 compatible intelligent device station (FX3U-64CCL) and one ver.2 compatible intelligent device station (FX3U-64CCL) are connected in the system.

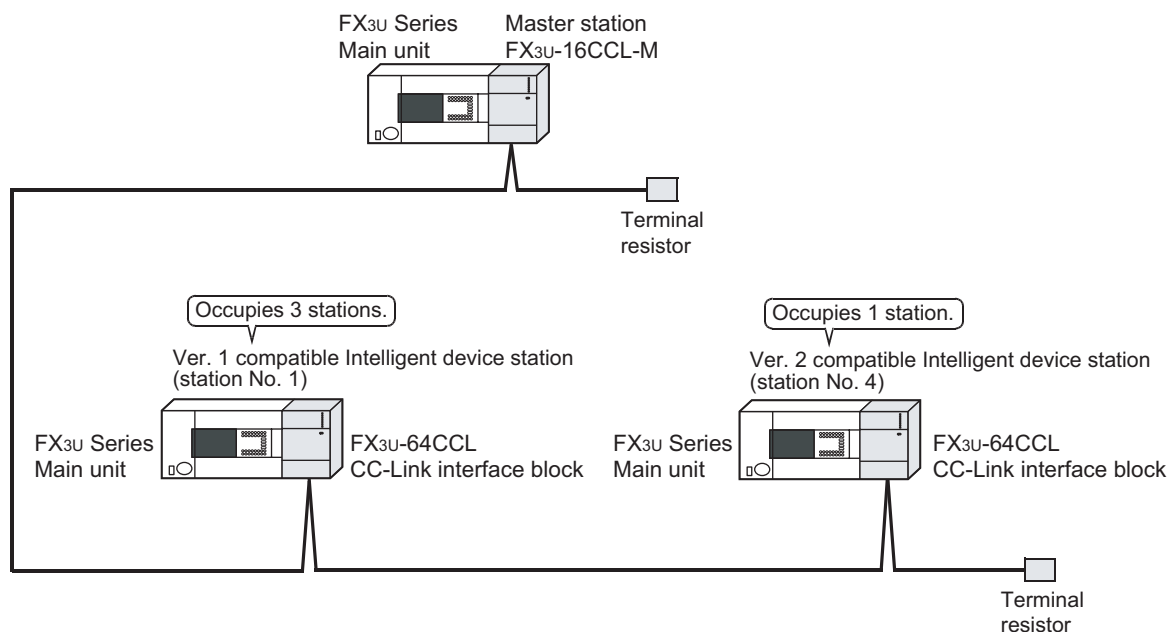

14.2.2 Setting of master station

The figure below shows the setting of the switches in the master station.

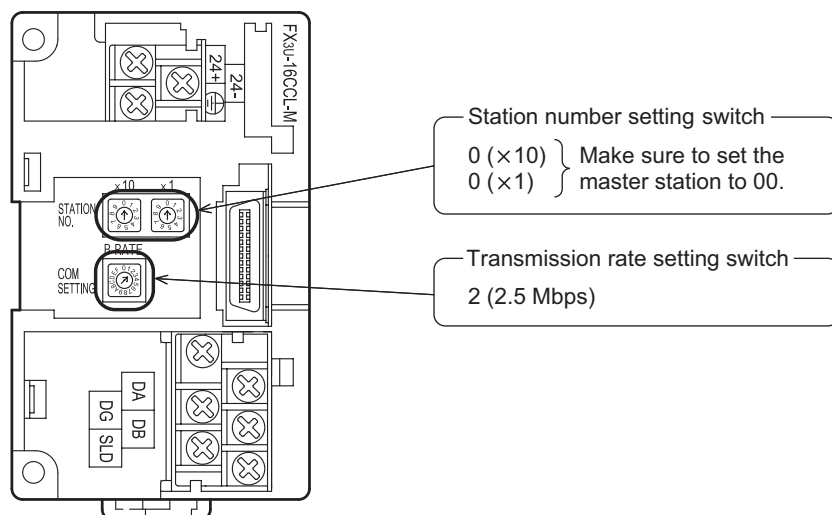

11

Programming

12

Remote I/O
Communication
Example

13

Remote Device
Communication
Example

14

Int. Device
Communication
Example

15

Compound Sys.
Communication
Example

16

Troubleshooting

A

Version
Information

B

Setting Sheet

C

Differences with
FX2N-16CCL-M

14.2.3 Setting of intelligent device station

The figure below shows the setting of the switches in the intelligent device station (FX3U-64CCL).

- FX3U-64CCL (Station No. 1)

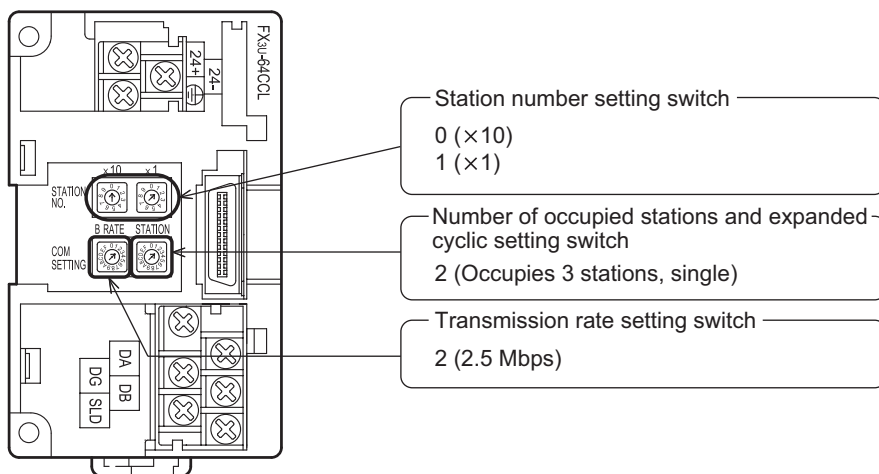

- FX3U-64CCL (Station No. 4)

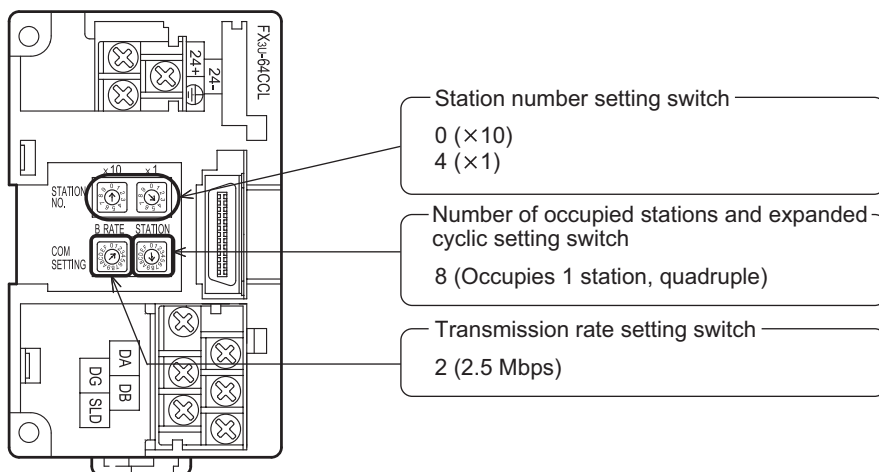

14.2.4 Setting of parameters

This Subsection describes parameter setup for performing a data link. This subsection describes parameter setup for performing data link using a sequence program. Refer to Section 8.5 for the setting method using network parameters. The program for parameters shown below is not required when parameters are set using network parameters.

1. Program for parameters

In the program below, data link automatically starts when the PLC starts to run.

Caution

The auxiliary relays in the non-keep area must be used as auxiliary relays (M) for parameter setting programs.

→ For the precautions in programming, refer to Section 11.1.

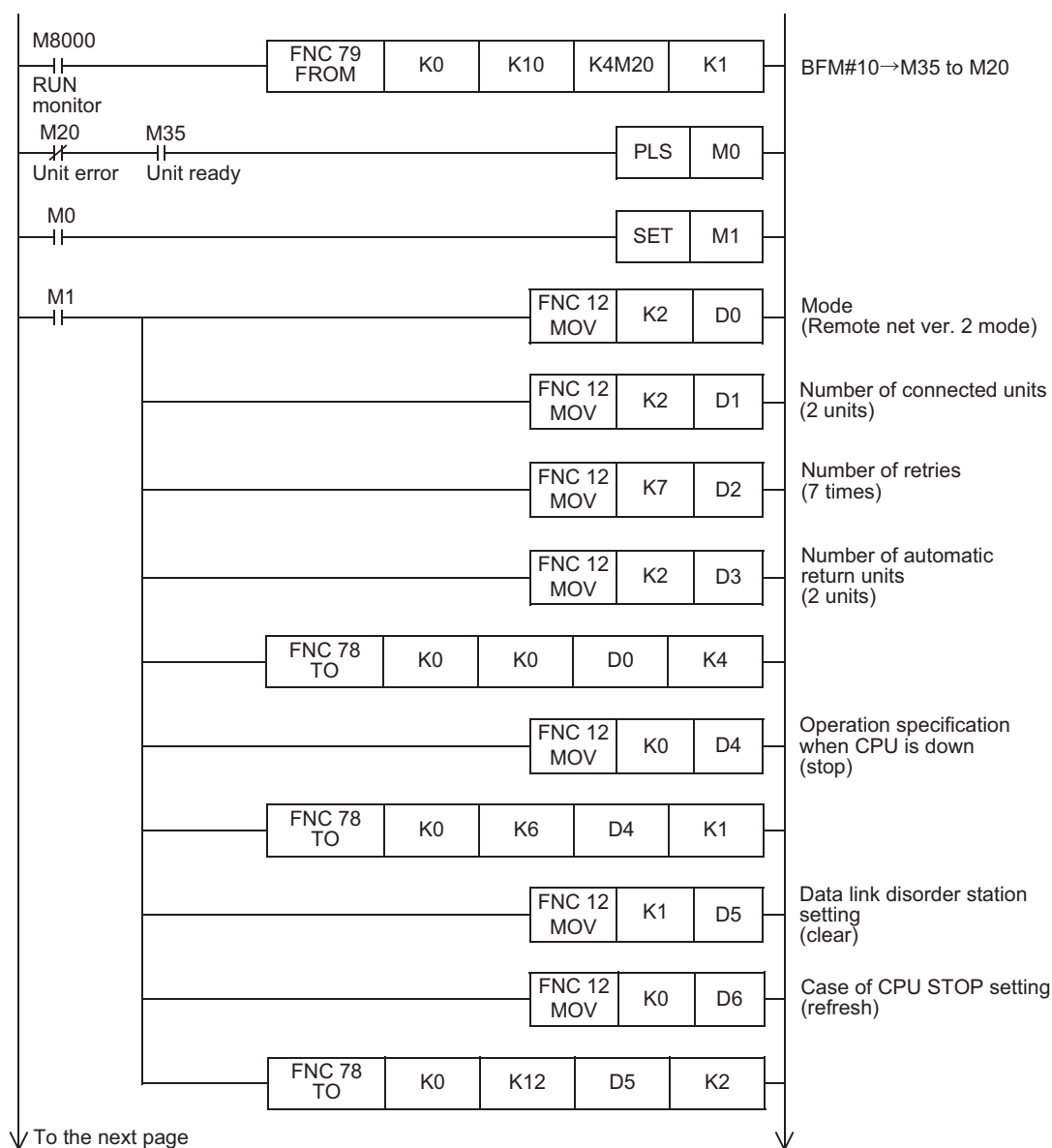

- 11 Programming
- 12 Remote I/O Communication Example
- 13 Remote Device Communication Example
- 14 Int. Device Communication Example
- 15 Compound Sys. Communication Example
- 16 Troubleshooting
- A Version Information
- B Setting Sheet
- C Differences with FX2N-16CCL-M

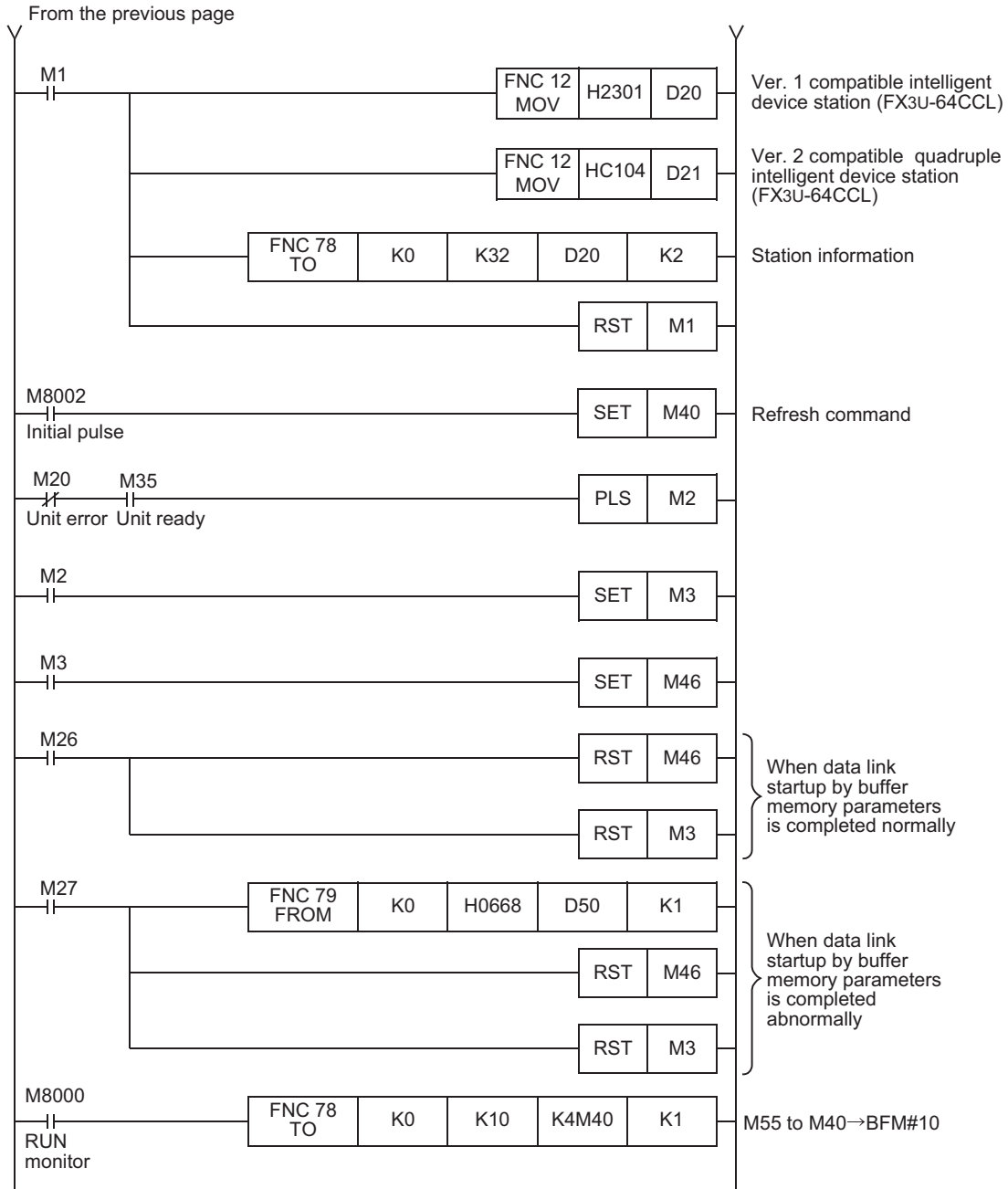

14.2.5 Creating a program for communication

This Subsection describes a program to control intelligent device stations (FX3U-64CCL).

- The relationship among the PLC, the master station buffer memory and the intelligent device stations.
 - Remote input (RX) and remote output (RY)

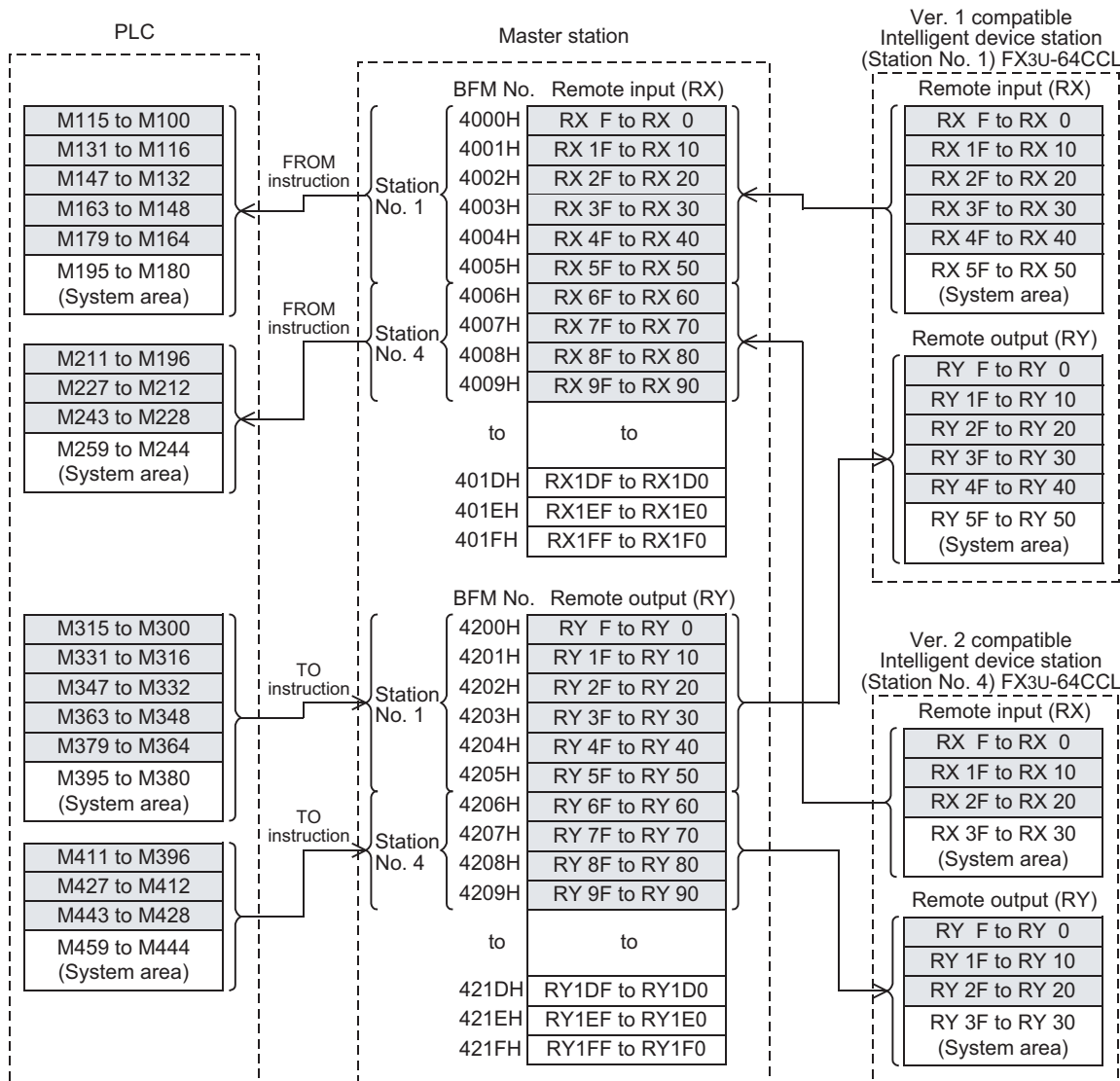

11	Programming
12	Remote I/O Communication Example
13	Remote Device Communication Example
14	Int. Device Communication Example
15	Compound Sys. Communication Example
16	Troubleshooting
A	Version Information
B	Setting Sheet
C	Differences with FX2N-16CCL-M

- Remote register (RWw, RWr)

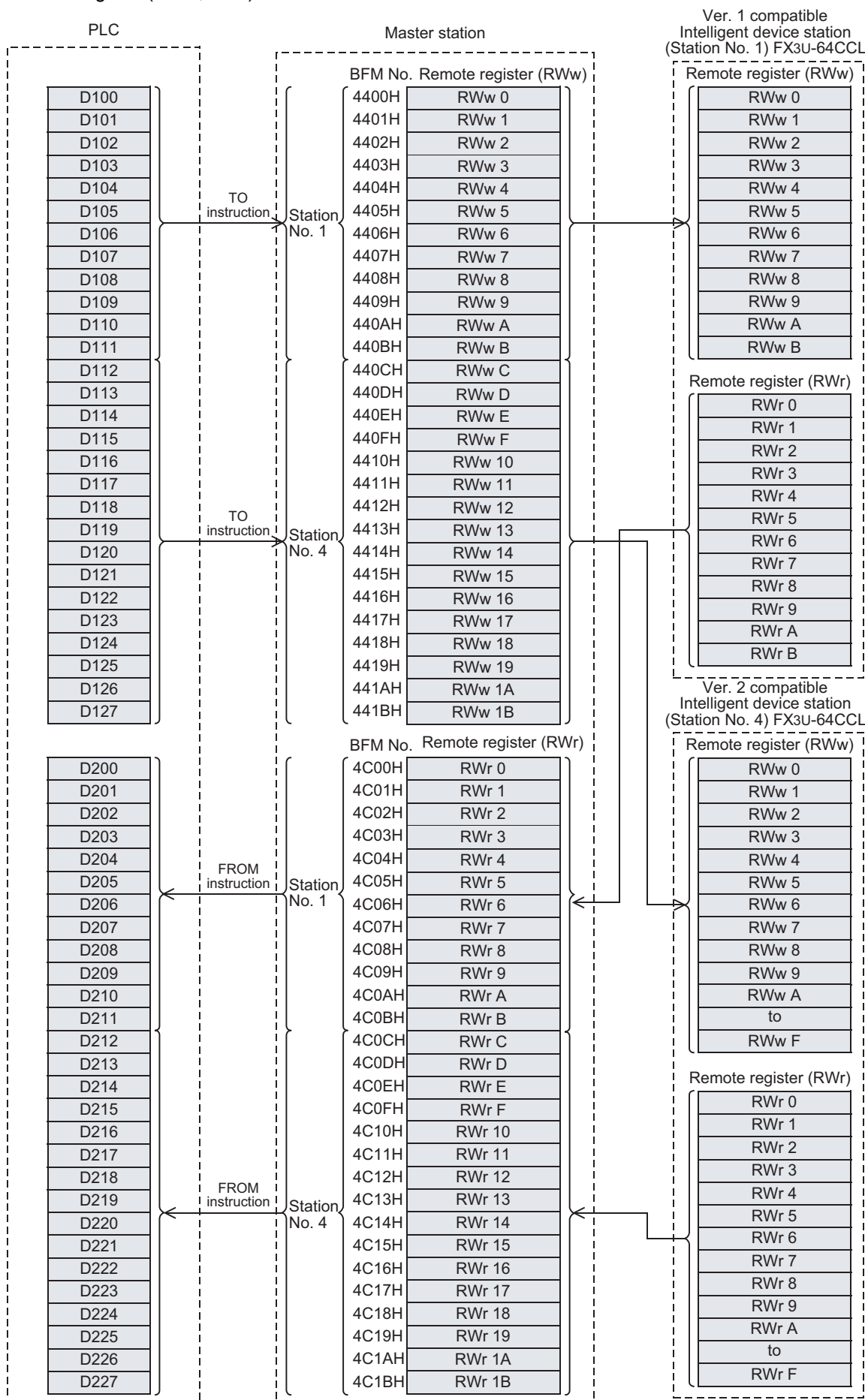

- Program to control intelligent device stations (FX3U-64CCL)

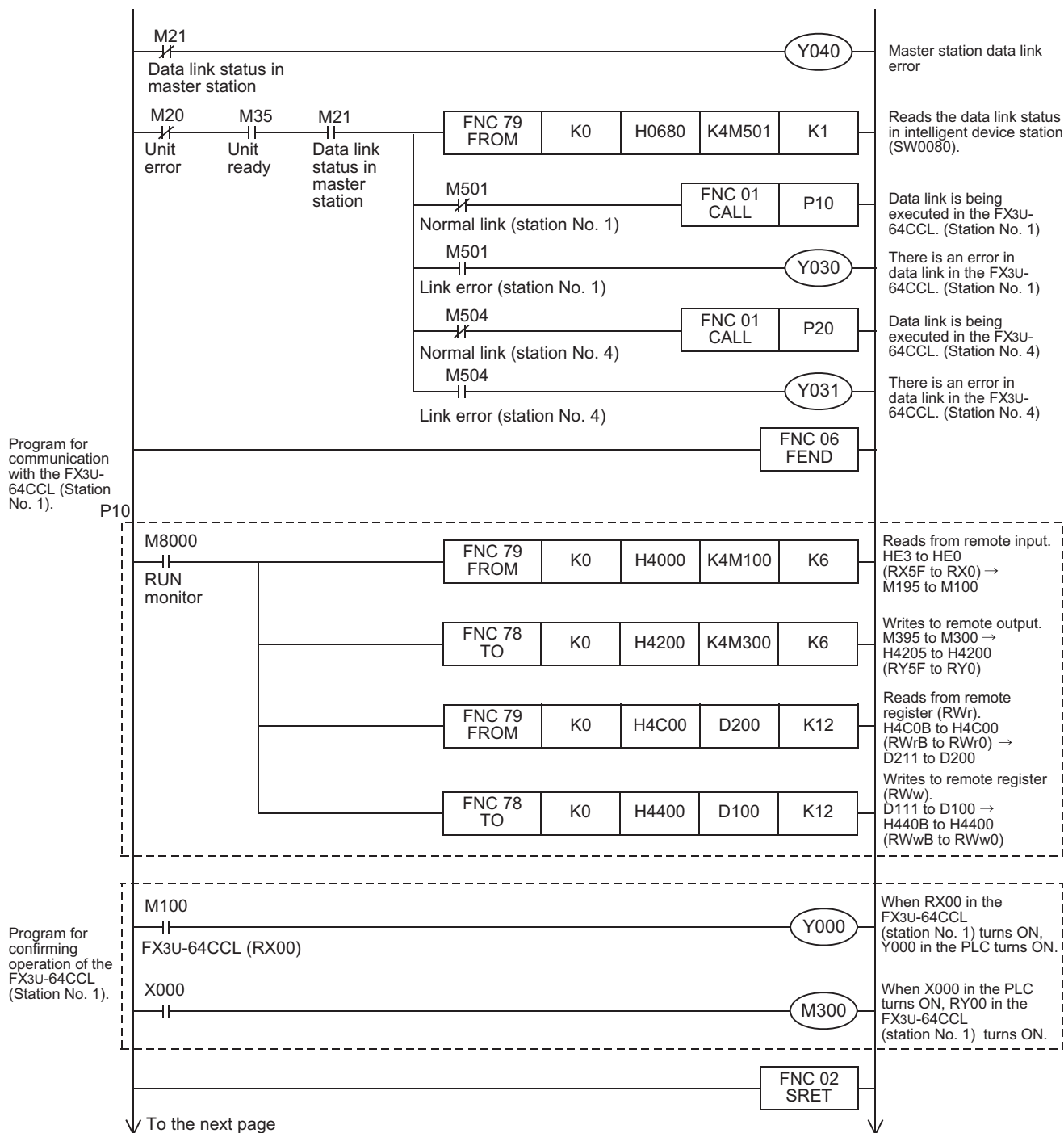

11	Programming
12	Remote I/O Communication Example
13	Remote Device Communication Example
14	Int. Device Communication Example
15	Compound Sys. Communication Example
16	Troubleshooting
A	Version Information
B	Setting Sheet
C	Differences with FX2N-16CCL-M

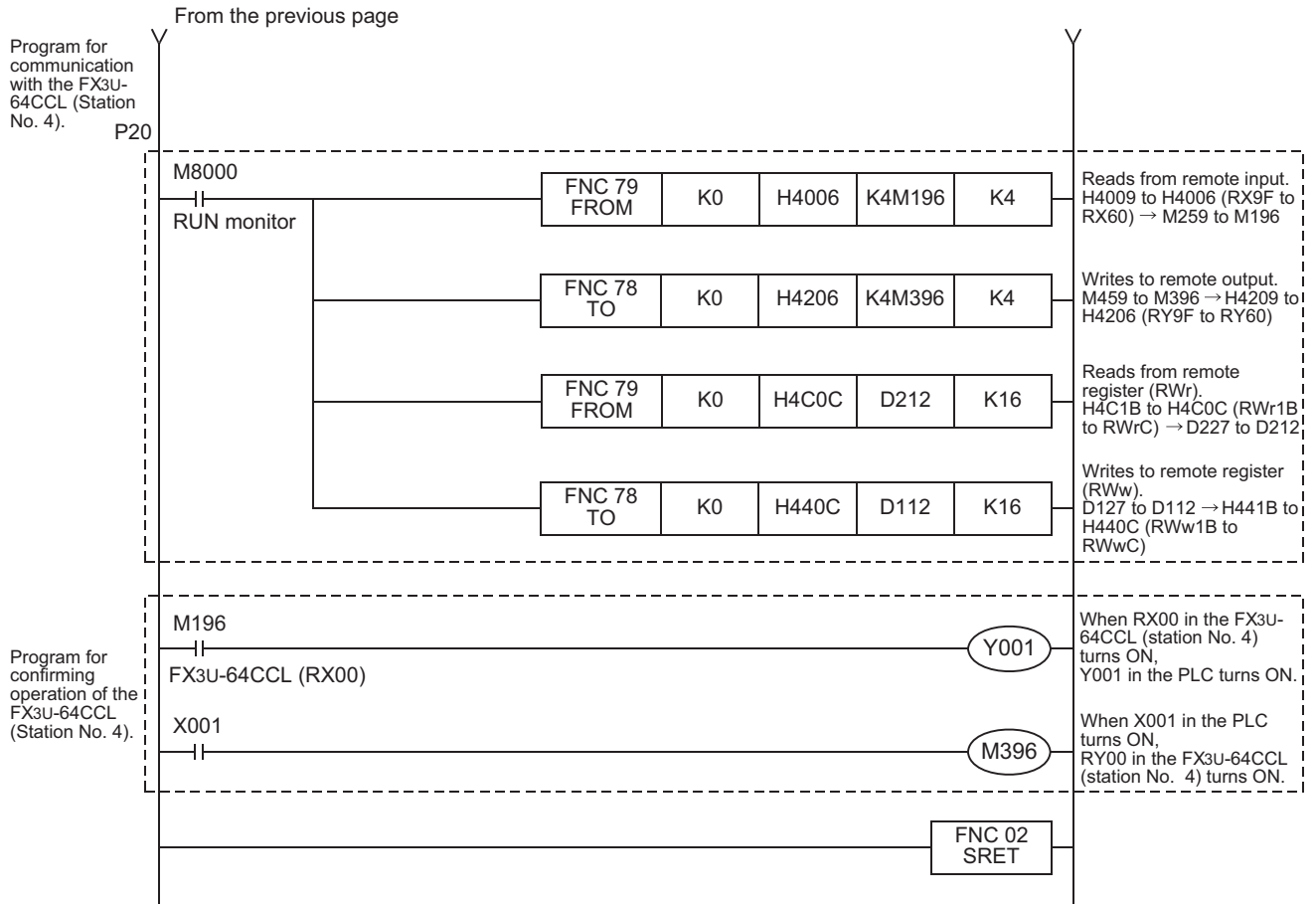

14.2.6 Execution of data link

Turn on the power of the intelligent device stations first, turn on the power of the master station, then start the data link.

14.2.7 Confirmation of operation by LED indication

The figures below show the LED indication status in the master station and the intelligent device stations while the data link is normally proceeding.

- LED indication in the master station
Make sure that the LED indication status is as shown below.

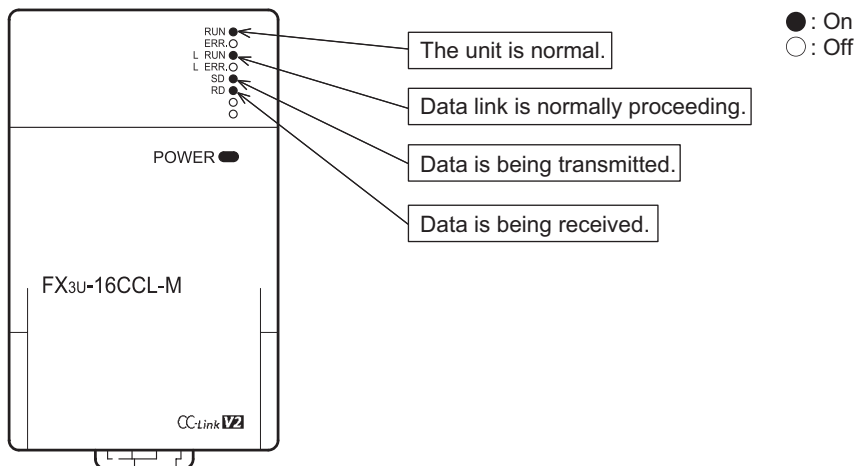

- LED indication in the intelligent device station (FX3U-64CCL)
Make sure that the LED indication status is as shown below.

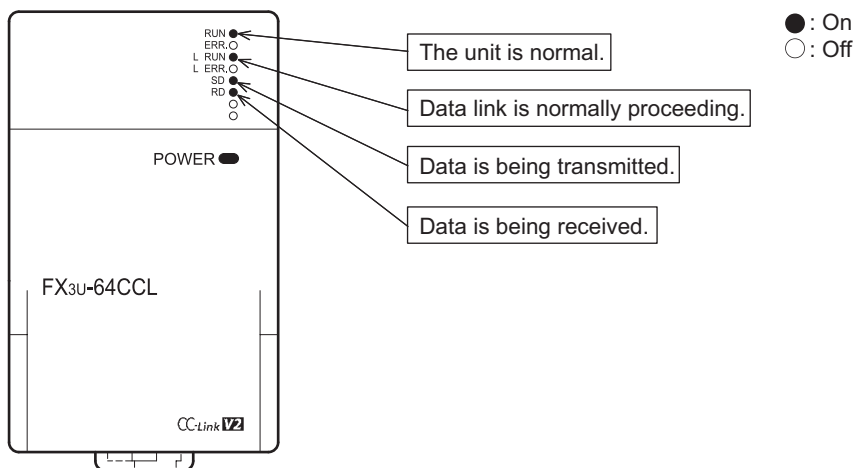

14.2.8 Confirmation of operation by program

Using a sequence program, make sure that data link is normally proceeding.

- 1) When X000 in the master station PLC turns ON, RY00 in the FX3U-64CCL (station No. 1) turns ON.
- 2) When RX00 in the FX3U-64CCL (station No. 1) turns ON, Y000 (M100) in the master station PLC turns ON.
- 3) When X001 in the master station PLC turns ON, RY40 in the FX3U-64CCL (station No. 4) turns ON.
- 4) When RX60 in the FX3U-64CCL (station No. 3) turns ON, Y001 (M196) in the master station PLC turns ON.

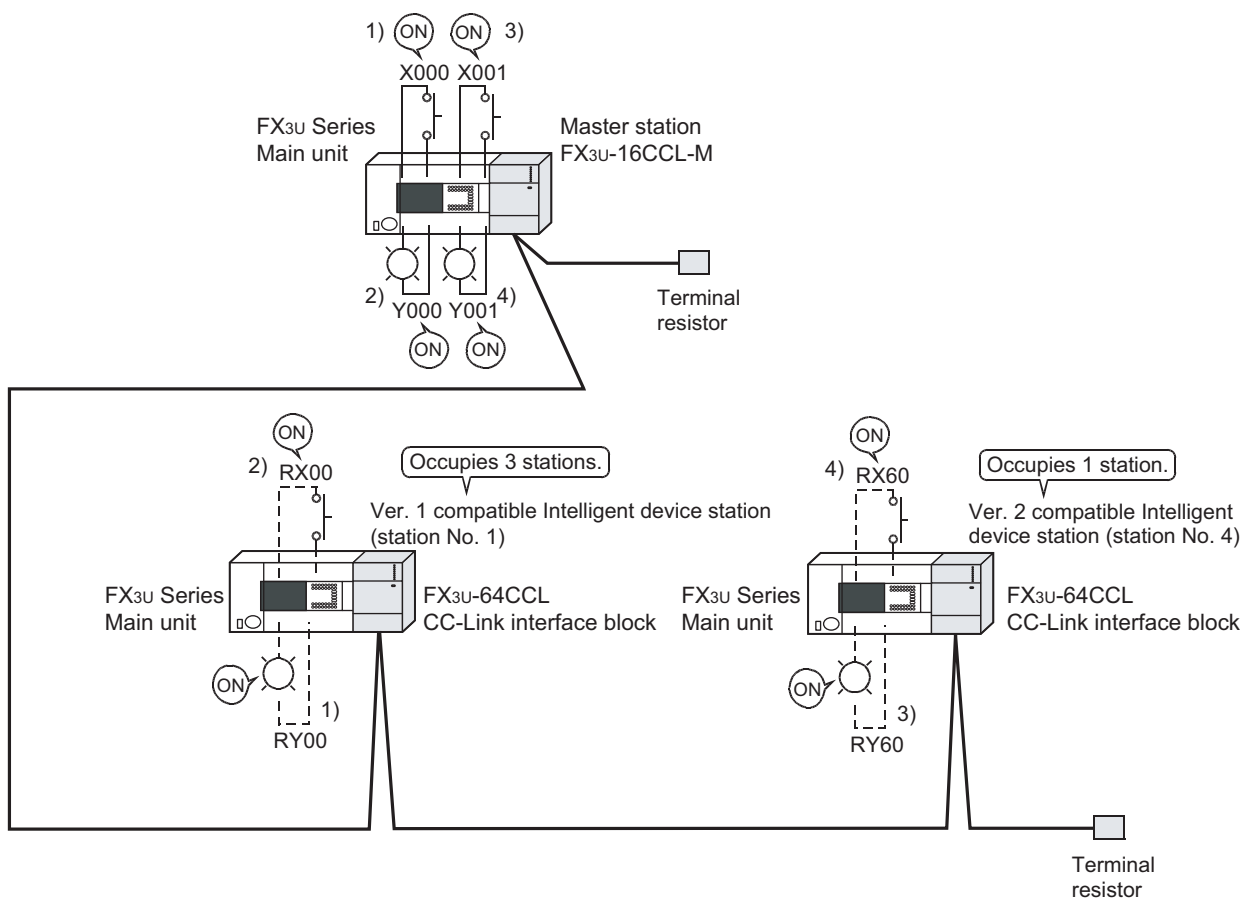

Caution

A program for communication is required also in the FX3U Series main unit connected to the FX3U-64CCL.

14.3 When Remote Net Additional Mode is Used

14.3.1 System configuration

It is supposed that one ver.1 compatible intelligent device station (FX3U-64CCL) and one ver.2 compatible intelligent device station (FX3U-64CCL) are connected in the system.

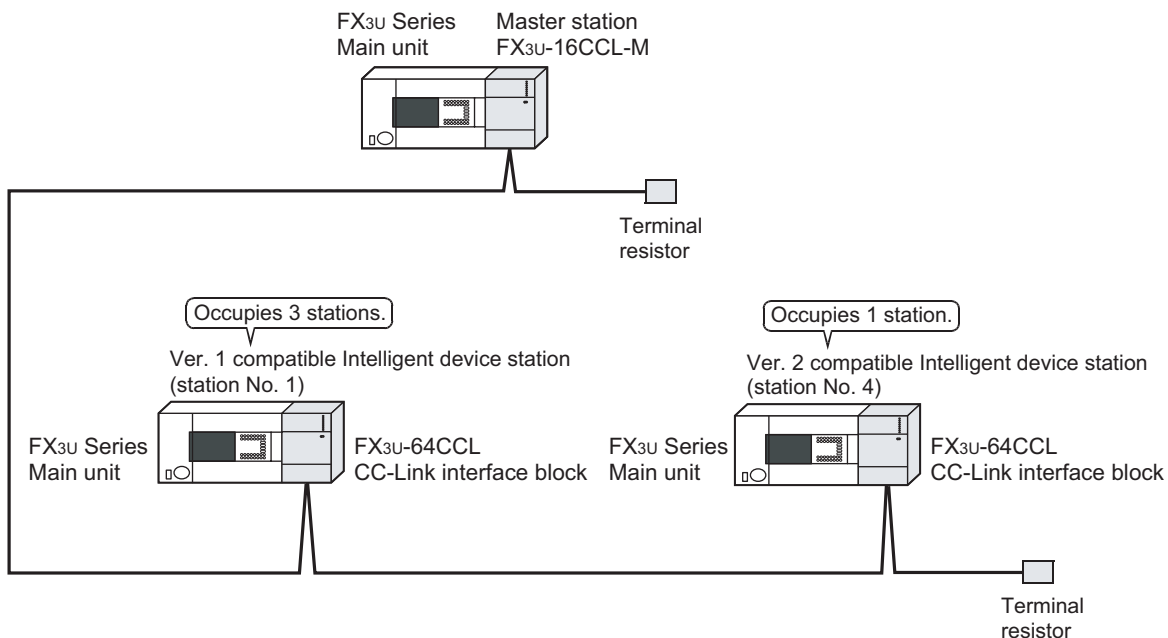

14.3.2 Setting of master station

The figure below shows the setting of the switches in the master station.

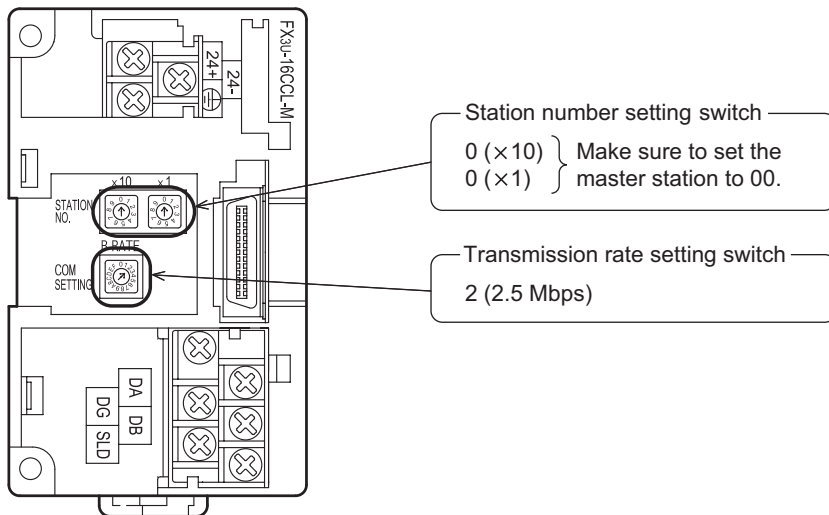

11	Programming
12	Remote I/O Communication Example
13	Remote Device Communication Example
14	Int. Device Communication Example
15	Compound Sys. Communication Example
16	Troubleshooting
A	Version Information
B	Setting Sheet
C	Differences with FX2N-16CCL-M

14.3.3 Setting of intelligent device station

The figure below shows the setting of the switches in the intelligent device station (FX3U-64CCL).

- FX3U-64CCL (Station No. 1)

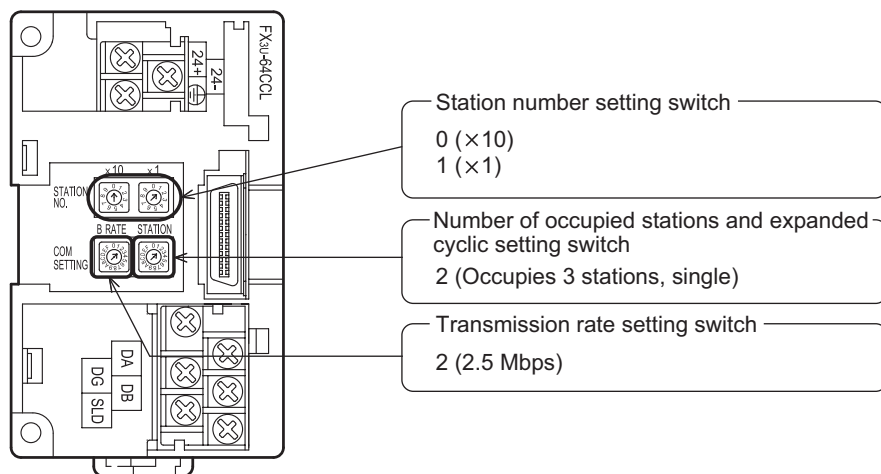

- FX3U-64CCL (Station No. 4)

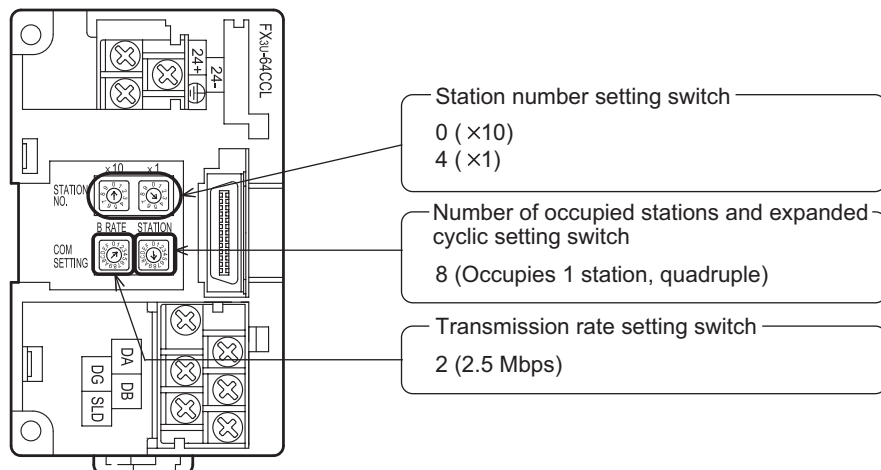

14.3.4 Setting of parameters

This Subsection describes parameter setup for performing a data link. This subsection describes parameter setup for performing data link using a sequence program. Refer to Section 8.5 for the setting method using network parameters. The program for parameters shown below is not required when parameters are set using network parameters.

1. Program for parameters

In the program below, data link automatically starts when the PLC starts to run.

Caution

The auxiliary relays in the non-keep area must be used as auxiliary relays (M) for parameter setting programs.

→ For the precautions in programming, refer to Section 11.1.

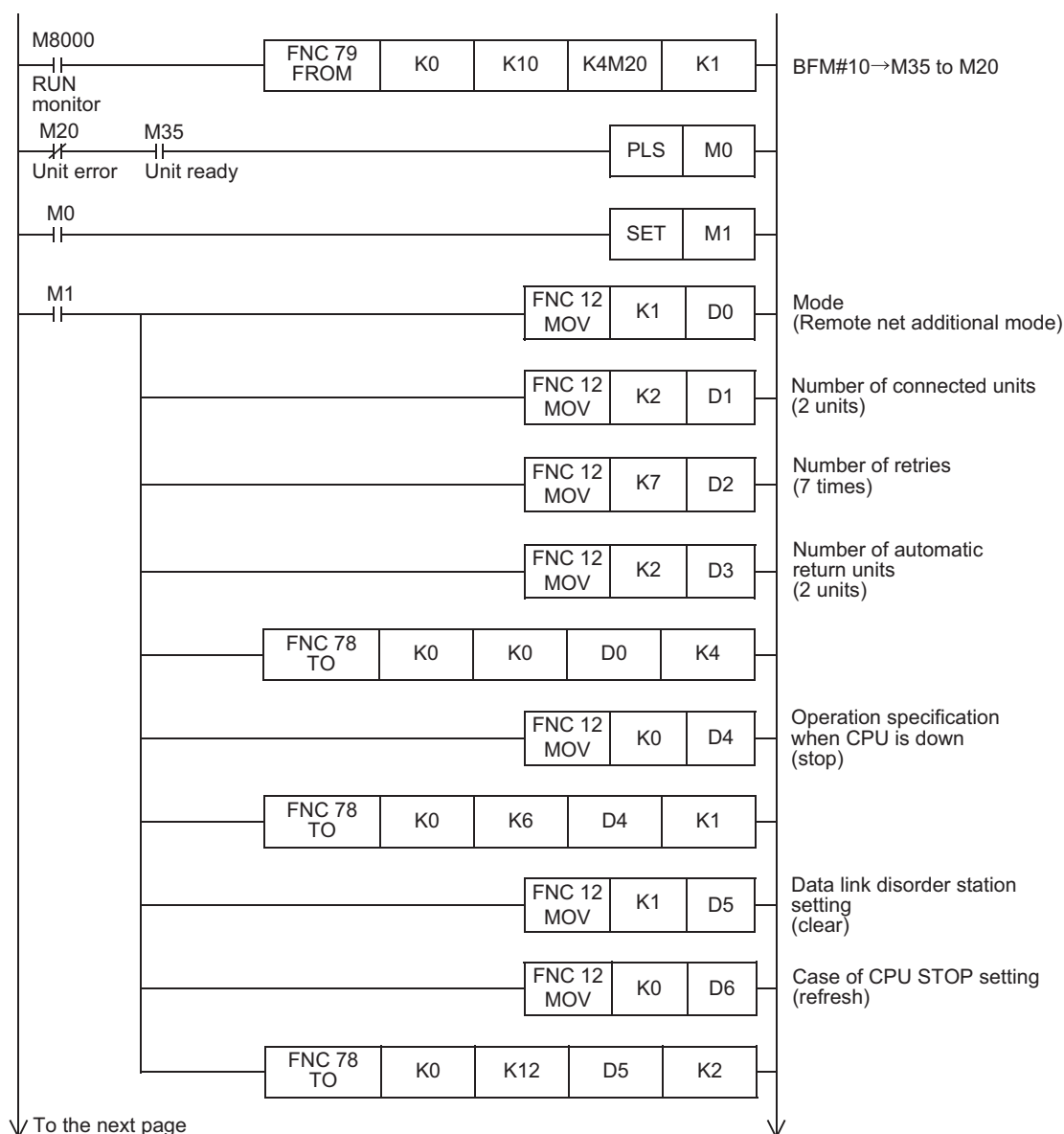

- 11 Programming
- 12 Remote I/O Communication Example
- 13 Remote Device Communication Example
- 14 Int. Device Communication Example
- 15 Compound Sys. Communication Example
- 16 Troubleshooting
- A Version Information
- B Setting Sheet
- C Differences with FX2N-16CCL-M

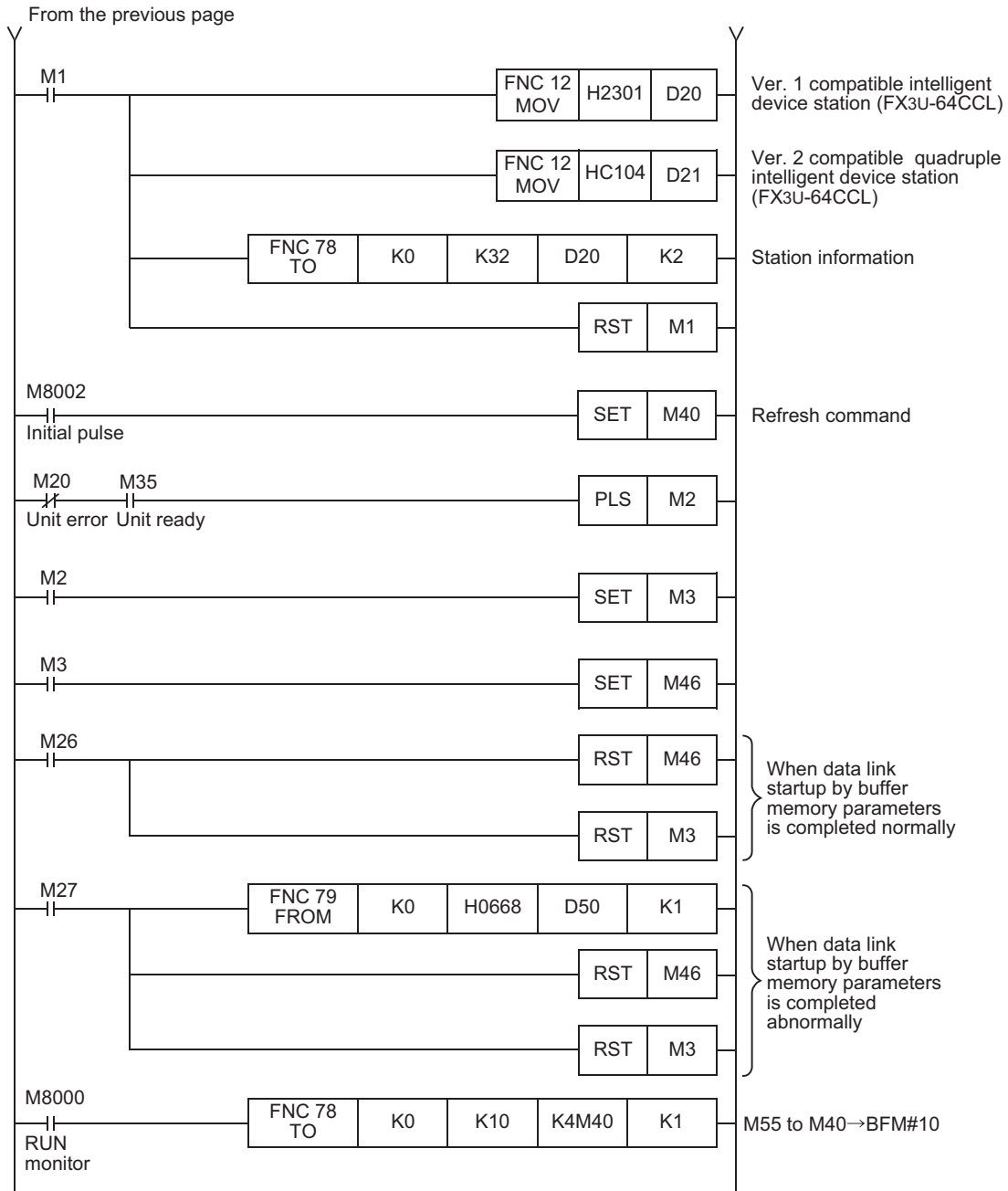

14.3.5 Creating a program for communication

This Subsection describes a program to control intelligent device stations (FX3U-64CCL).

- The relationship among the PLC, the master station buffer memory and the intelligent device stations.
 - Remote input (RX) and remote output (RY)

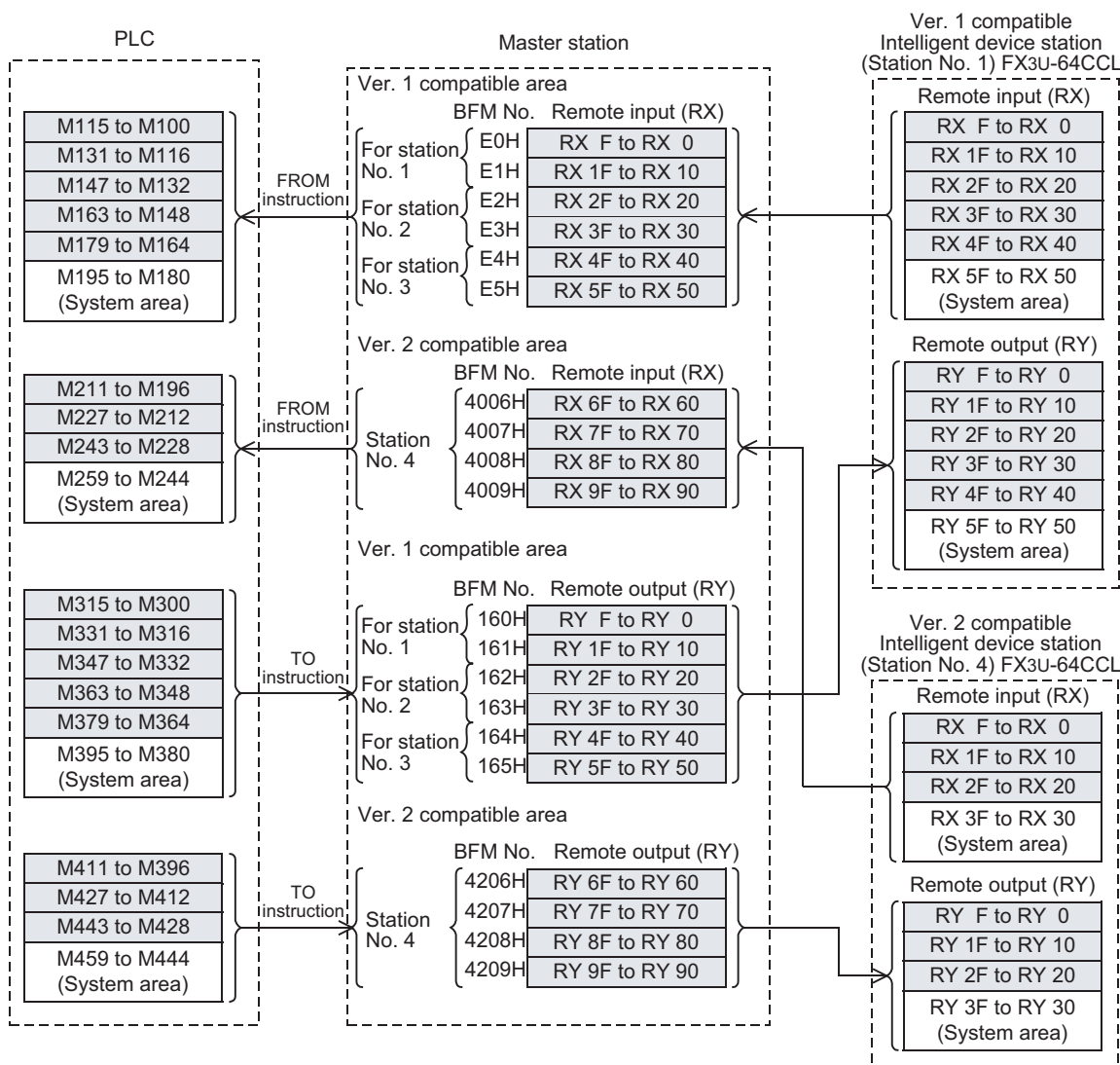

11	Programming
12	Remote I/O Communication Example
13	Remote Device Communication Example
14	Int. Device Communication Example
15	Compound Sys. Communication Example
16	Troubleshooting
A	Version Information
B	Setting Sheet
C	Differences with FX2N-16CCL-M

- Remote register (RWw, RWr)

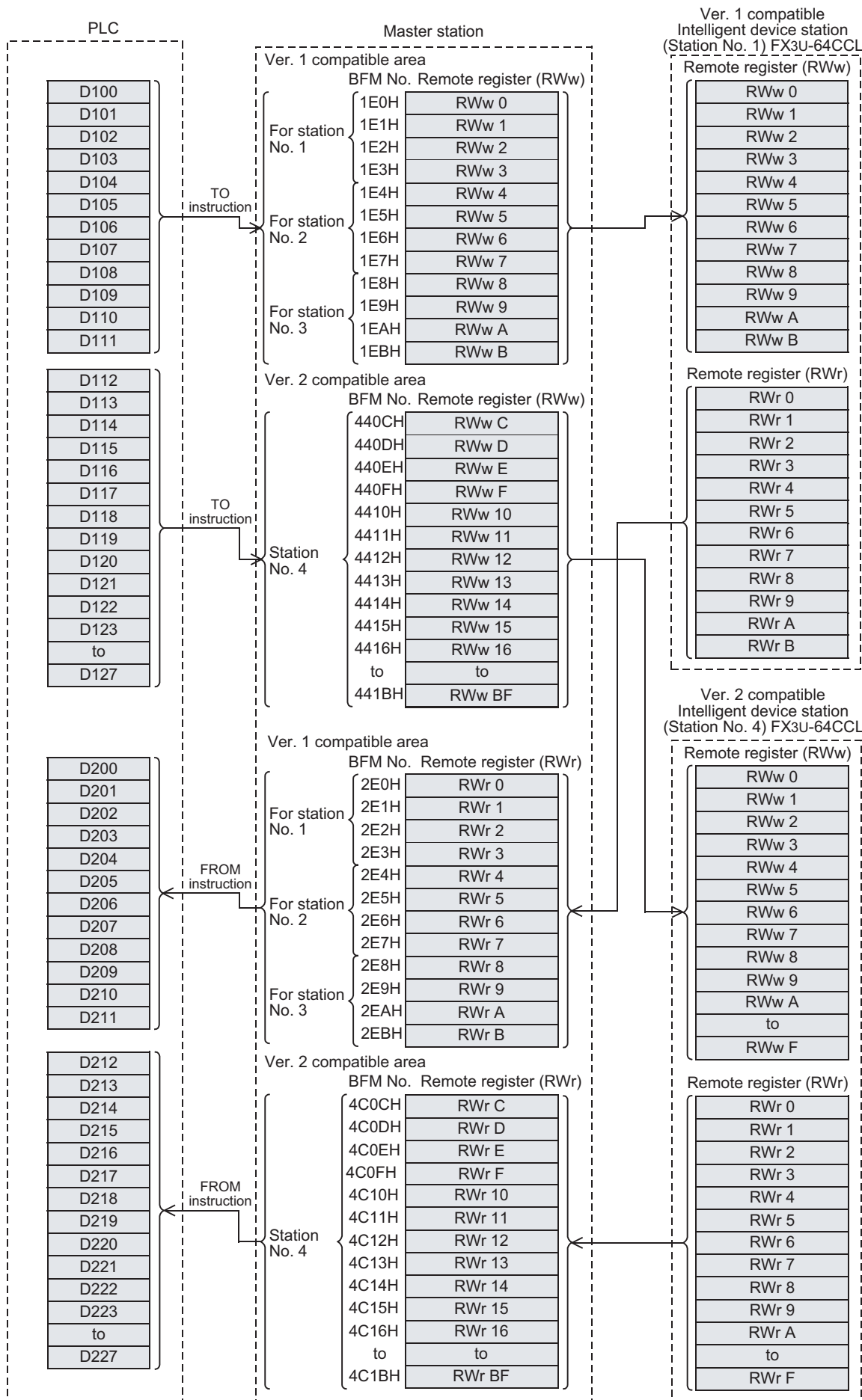

- Program to control intelligent device stations (FX3U-64CCL)

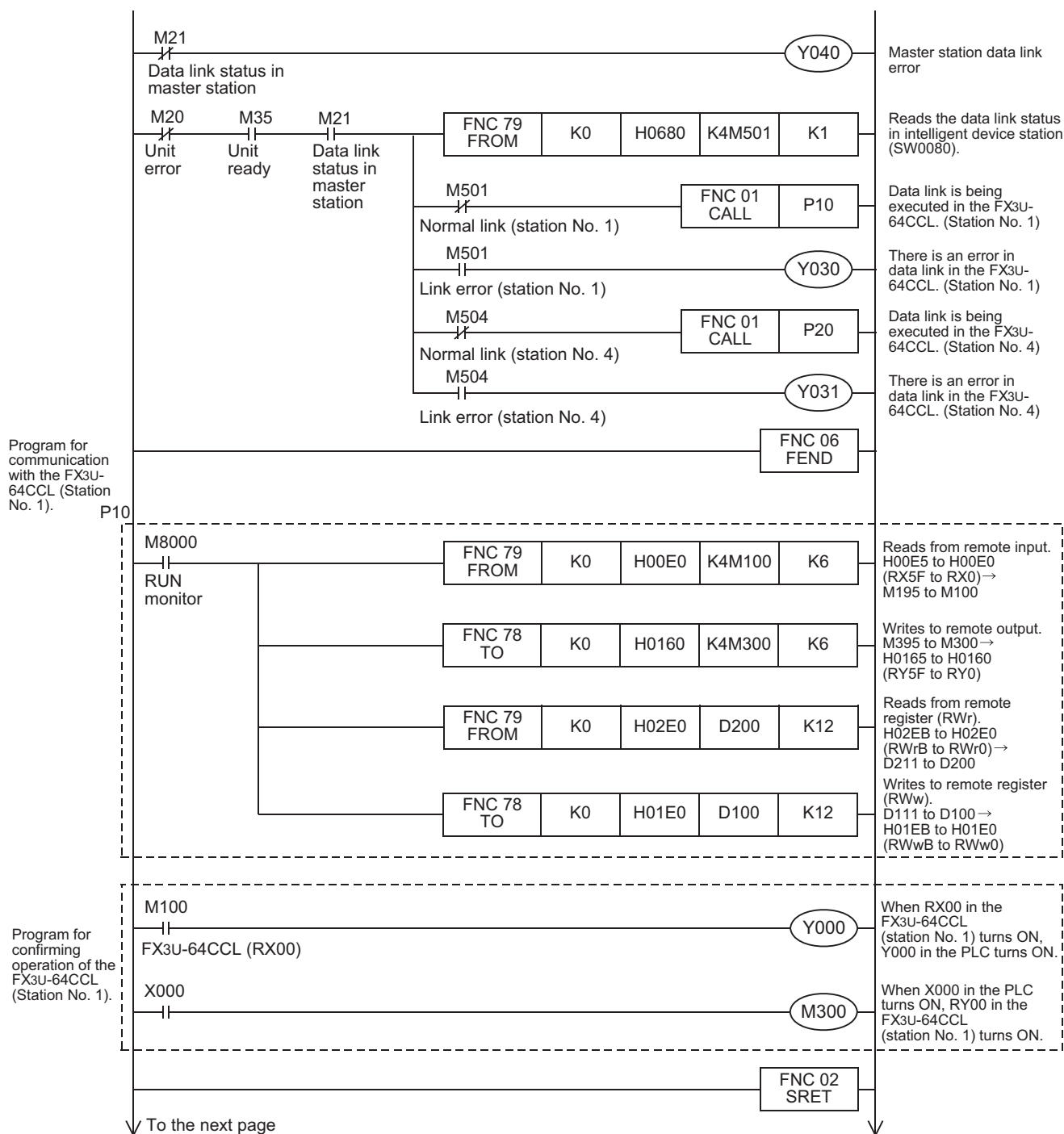

11	Programming
12	Remote I/O Communication Example
13	Remote Device Communication Example
14	Int. Device Communication Example
15	Compound Sys. Communication Example
16	Troubleshooting
A	Version Information
B	Setting Sheet
C	Differences with FX2N-16CCL-M

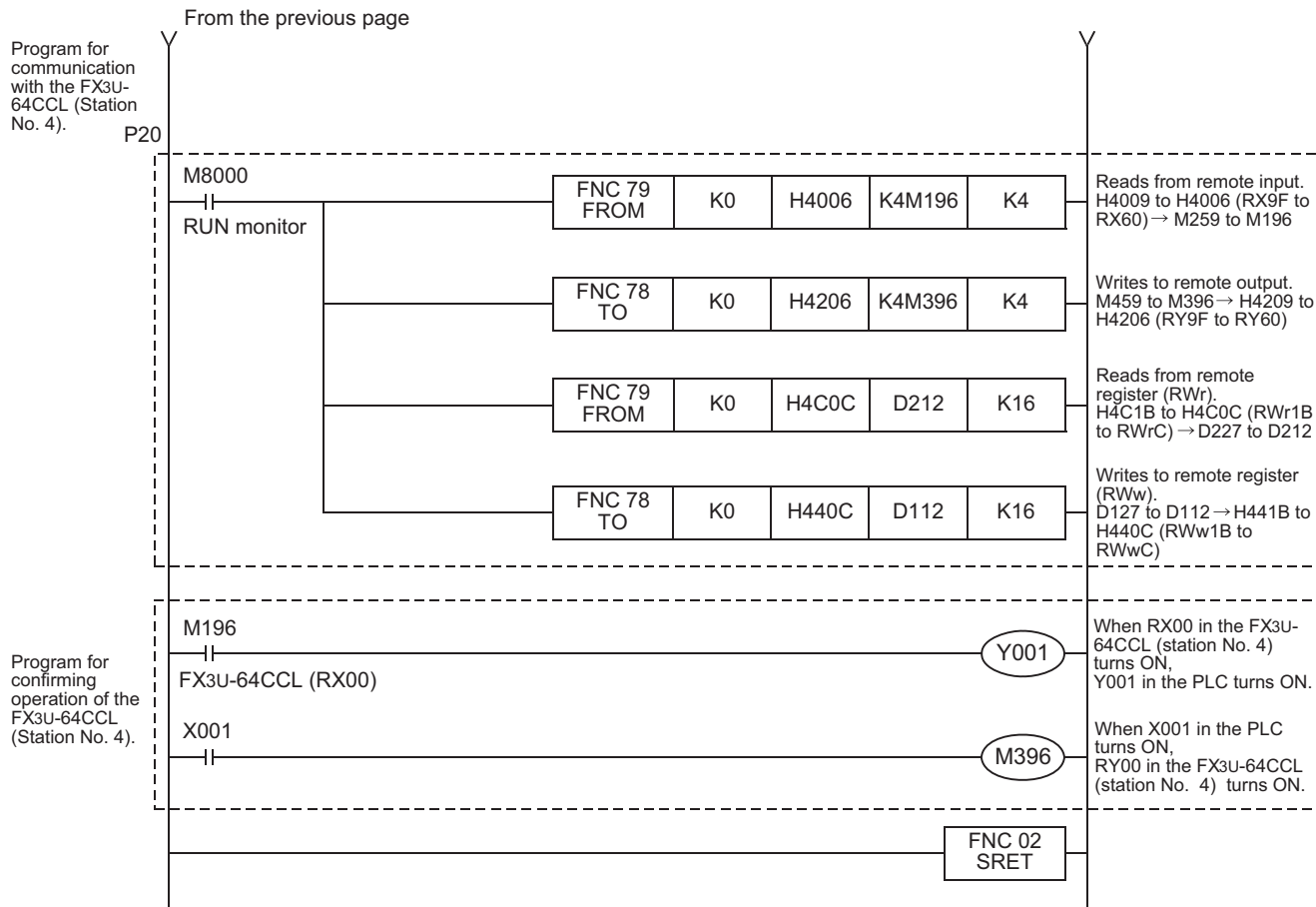

14.3.6 Execution of data link

Turn on the power of the intelligent device stations first, turn on the power of the master station, then start the data link.

14.3.7 Confirmation of operation by LED indication

The figures below show the LED indication status in the master station and the intelligent device stations while the data link is normally proceeding.

- LED indication in the master station
Make sure that the LED indication status is as shown below.

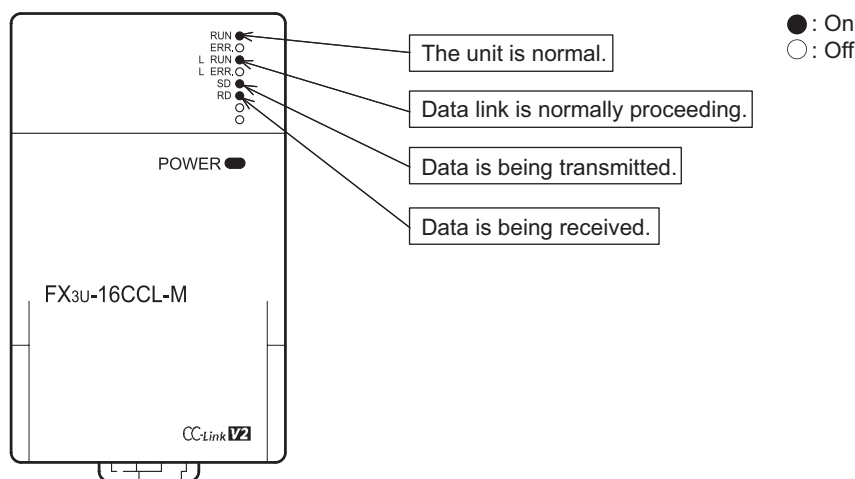

- LED indication in the intelligent device station (FX3U-64CCL)
Make sure that the LED indication status is as shown below.

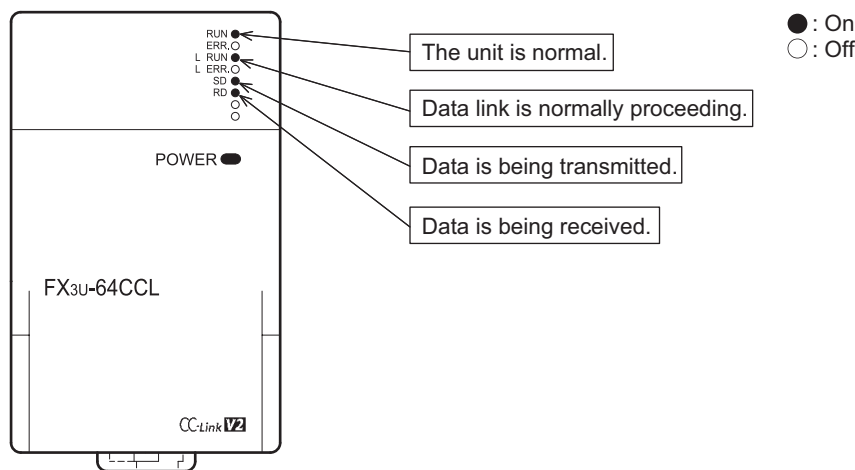

11

Programming

12

Remote I/O
Communication
Example

13

Remote Device
Communication
Example

14

Int. Device
Communication
Example

15

Compound Sys.
Communication
Example

16

Troubleshooting

A

Version
Information

B

Setting Sheet

C

Differences with
FX2N-16CCL-M

14.3.8 Confirmation of operation by program

Using a sequence program, make sure that data link is normally proceeding.

- 1) When X000 in the master station PLC turns ON, RY00 in the FX3U-64CCL (station No. 1) turns ON.
- 2) When RX00 in the FX3U-64CCL (station No. 1) turns ON, Y000 (M100) in the master station PLC turns ON.
- 3) When X001 in the master station PLC turns ON, RY60 in the FX3U-64CCL (station No. 4) turns ON.
- 4) When RX60 in the FX3U-64CCL (station No. 4) turns ON, Y001 (M196) in the master station PLC turns ON.

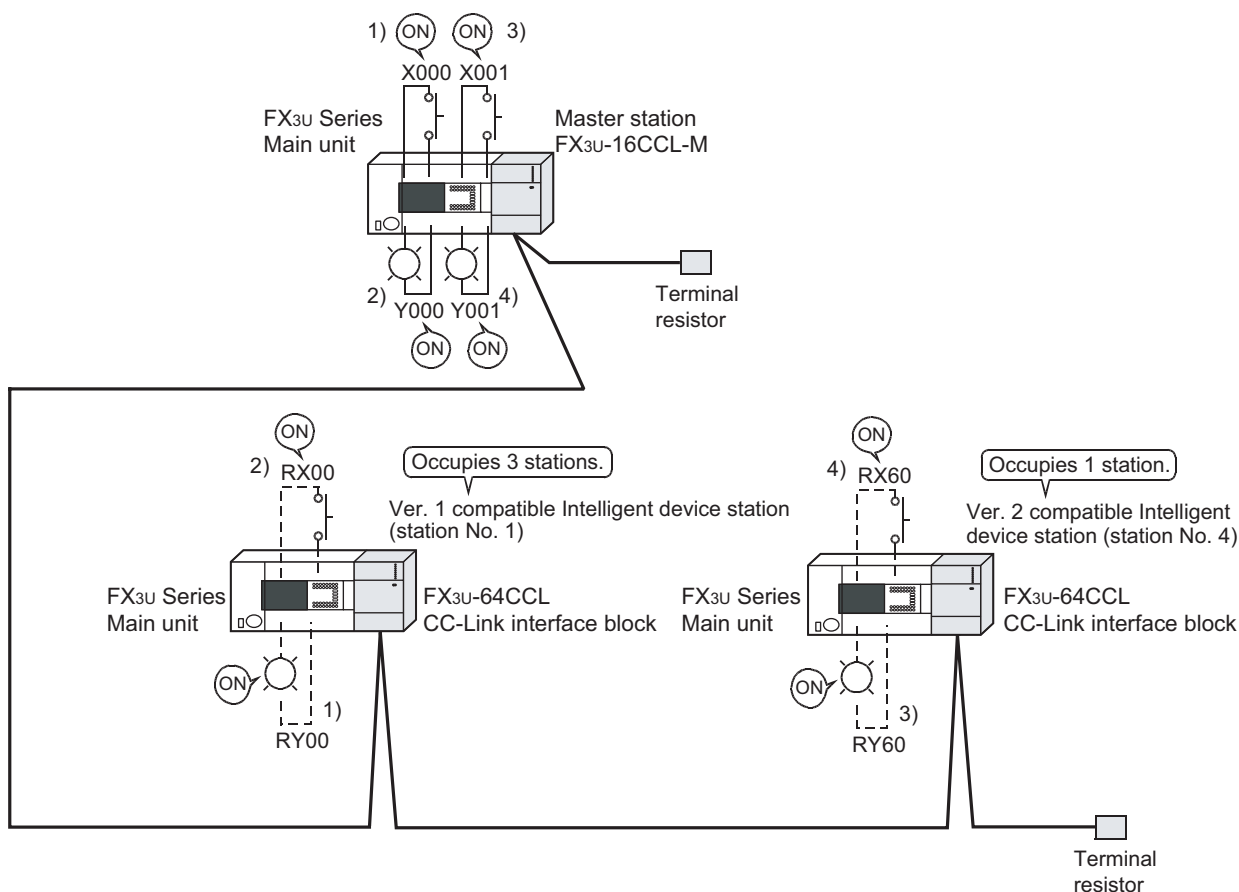

Caution

A program for communication is required also in the FX3U Series main unit connected to the FX3U-64CCL.

15. Example of Communication in Compound System

This chapter explains the procedures from unit settings to parameter settings, programming, and finally operation check using a system configuration example.
The example which uses a FROM/TO instructions explains read/write of a buffer memory. For the other methods, refer to the programming manual.

15.1 When Remote Net Ver. 1 Mode is Used

15.1.1 System configuration

It is supposed that one remote I/O station, one remote device station (FX2N-32CCL) and one intelligent device station (FX3U-64CCL) are connected in the system.

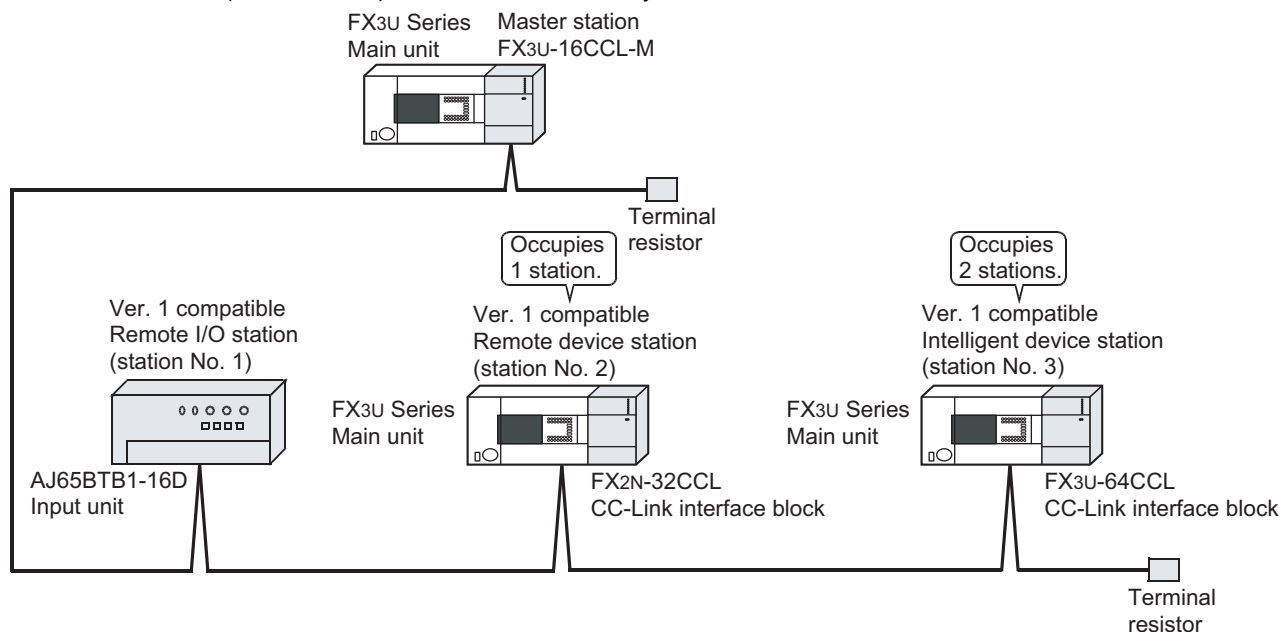

15.1.2 Setting of master station

The figure below shows the setting of the switches in the master station.

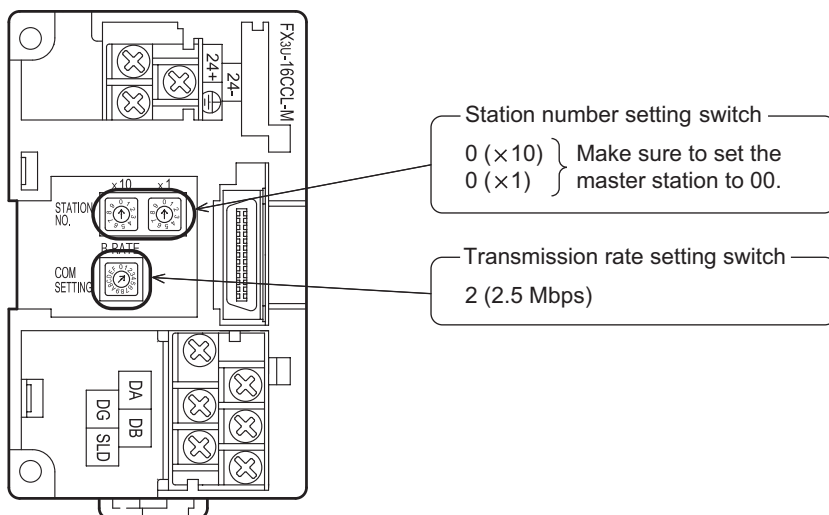

15.1.3 Setting of remote I/O station

The figure below shows the setting of the switches in the remote I/O station.

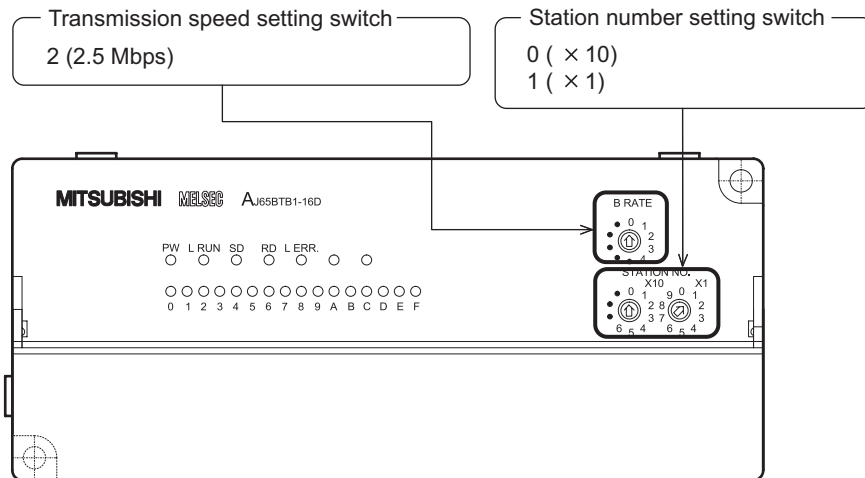

15.1.4 Setting of remote device station

The figure below shows the setting of the switches in the remote device station.

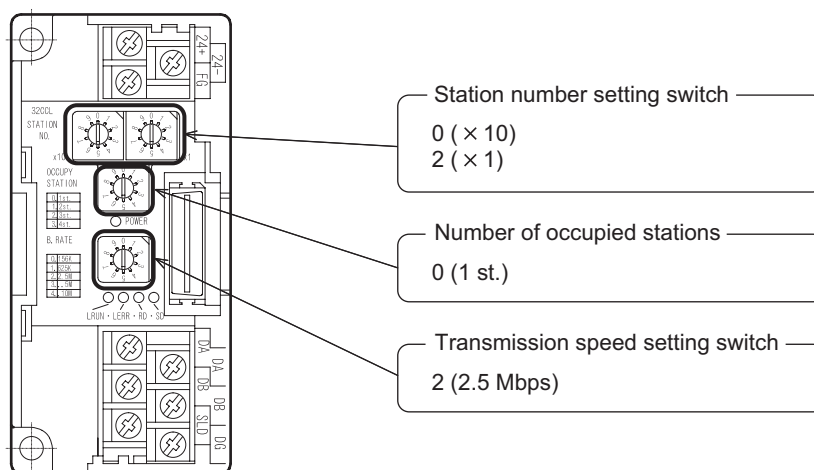

15.1.5 Setting of intelligent device station

The figure below shows the setting of the switches in the intelligent device station.

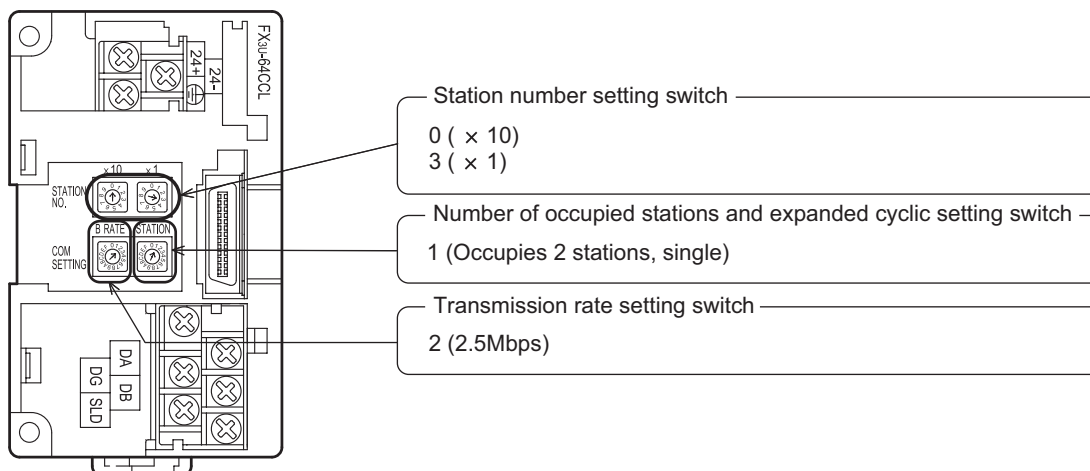

15.1.6 Setting of parameters

This Subsection describes parameter setup for performing a data link. This subsection describes parameter setup for performing data link using a sequence program. Refer to Section 8.5 for the setting method using network parameters. The program for parameters shown below is not required when parameters are set using network parameters.

1. Program for parameters

In the program below, data link automatically starts when the PLC starts to run.

Caution

The auxiliary relays in the non-keep area must be used as auxiliary relays (M) for parameter setting programs.

→ For the precautions in programming, refer to Section 11.1.

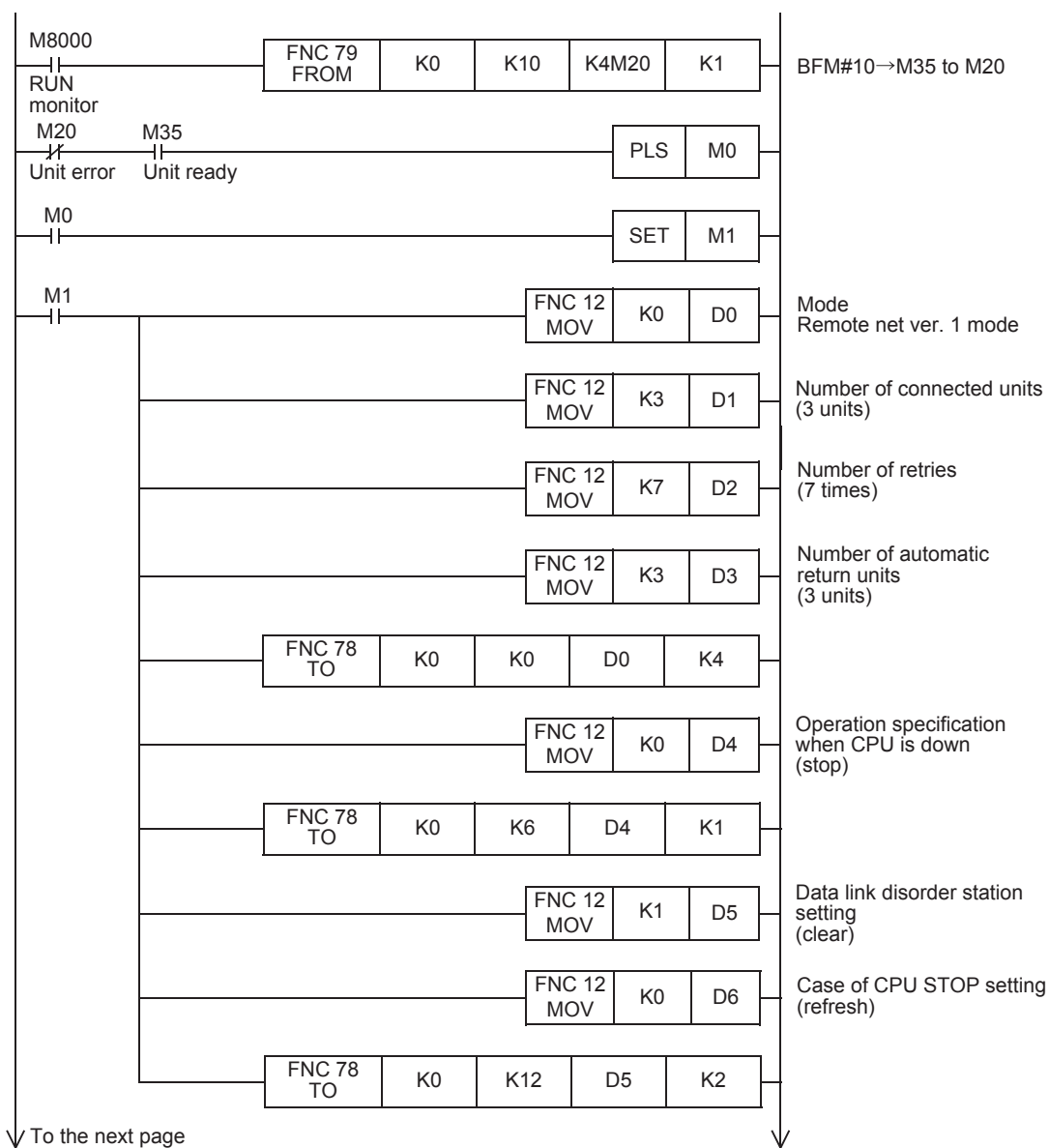

- 11 Programming
- 12 Remote I/O Communication Example
- 13 Remote Device Communication Example
- 14 Int. Device Communication Example
- 15 Compound Sys. Communication Example
- 16 Troubleshooting
- A Version Information
- B Setting Sheet
- C Differences with FX2N-16CCL-M

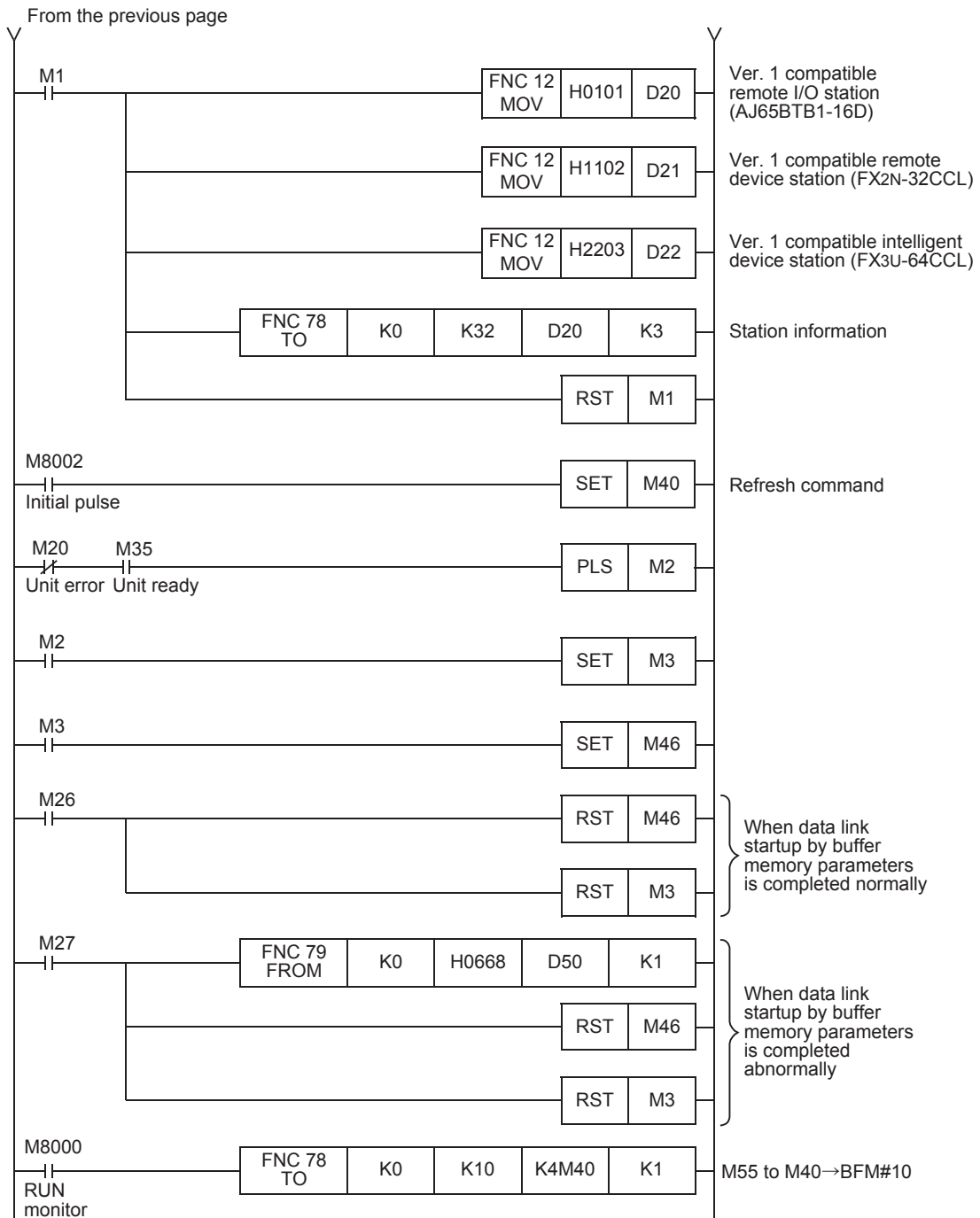

15.1.7 Creating a program for communication

This Subsection describes a program to control remote I/O stations, remote device stations and intelligent device stations.

- The relationship among the PLC, the master station buffer memory, remote I/O stations, remote device stations and intelligent device stations.
 - Remote input (RX) and remote output (RY)

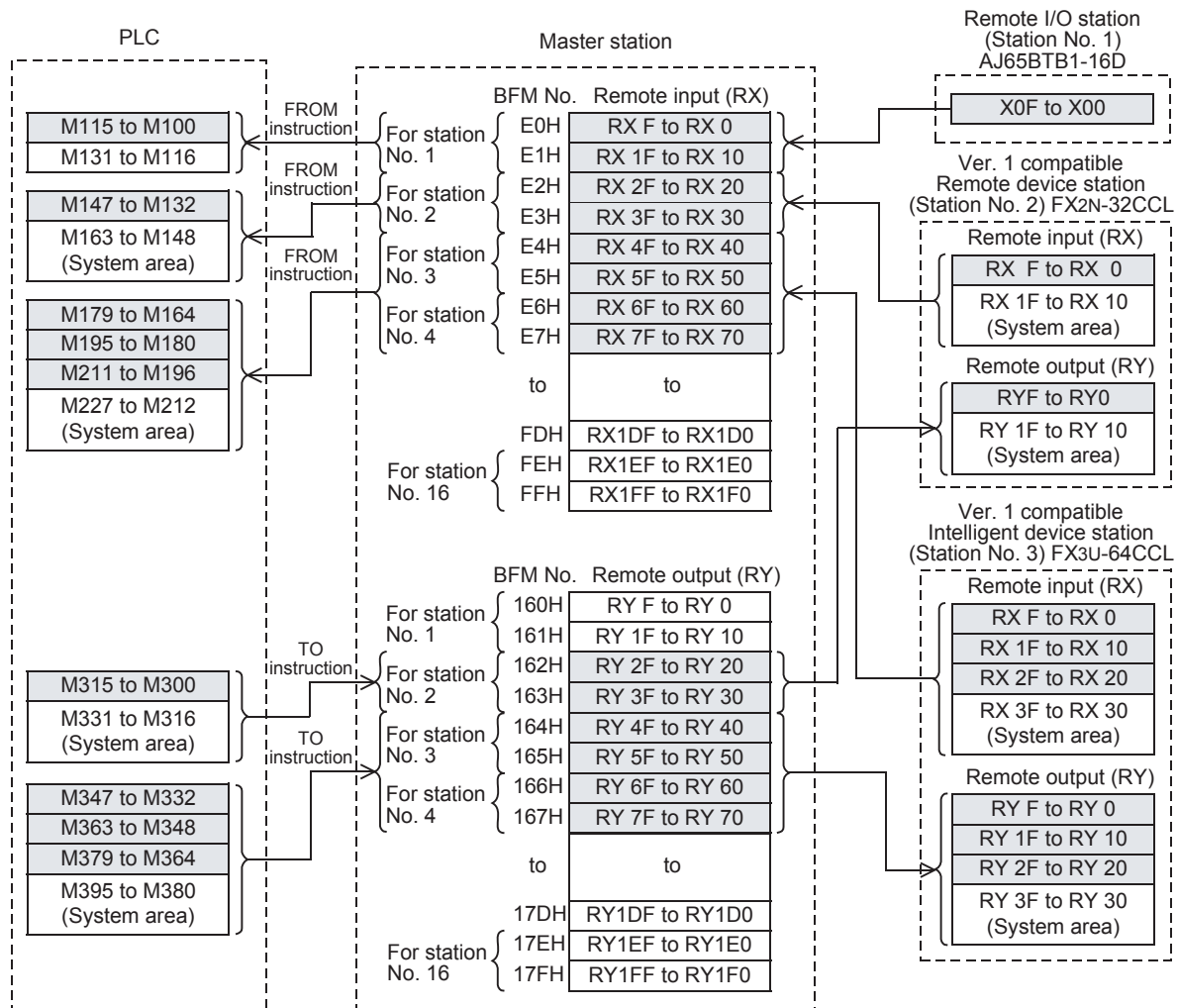

- Remote register (RWw, RWr)

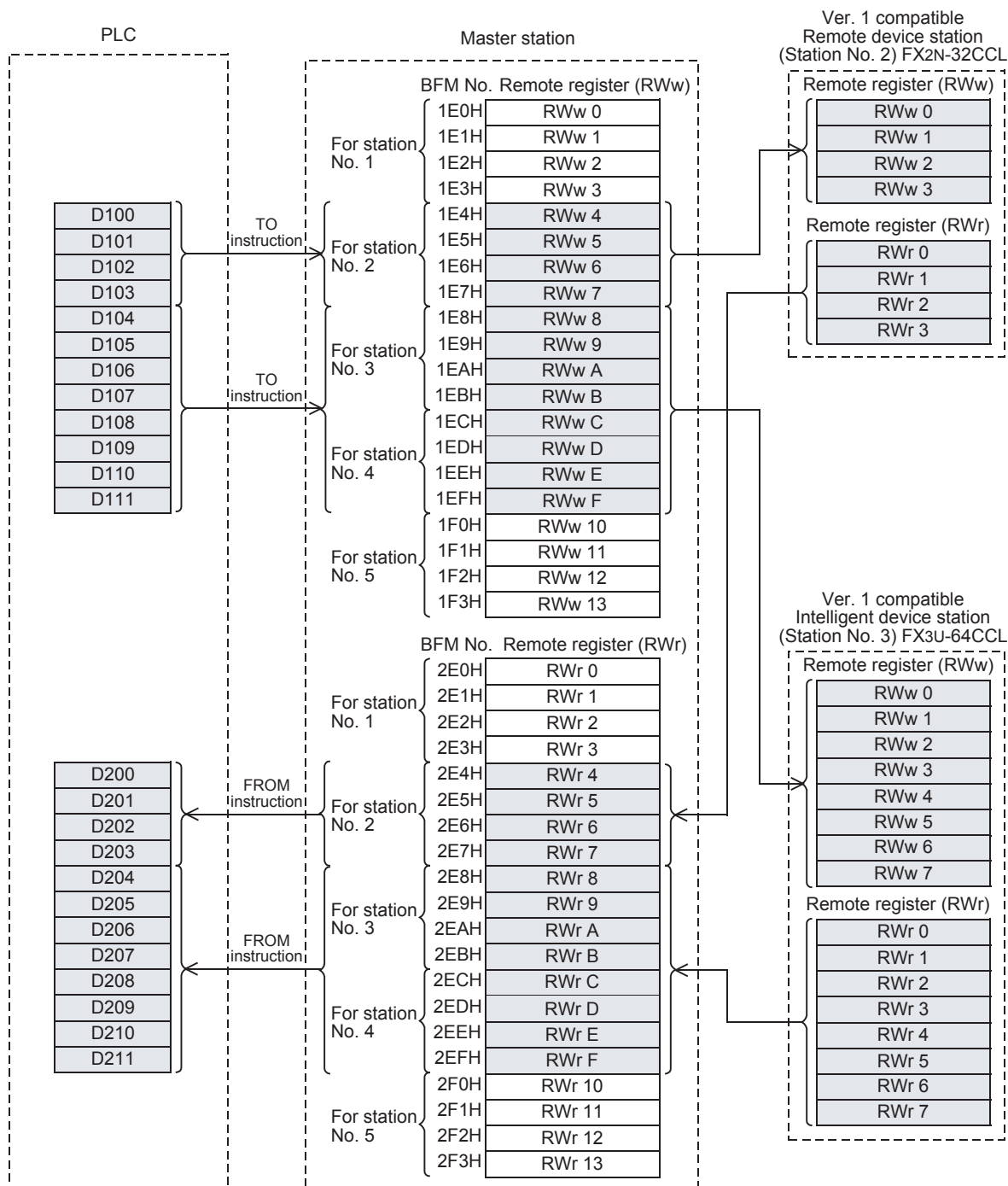

- Program to control remote I/O stations, remote device stations and intelligent device stations

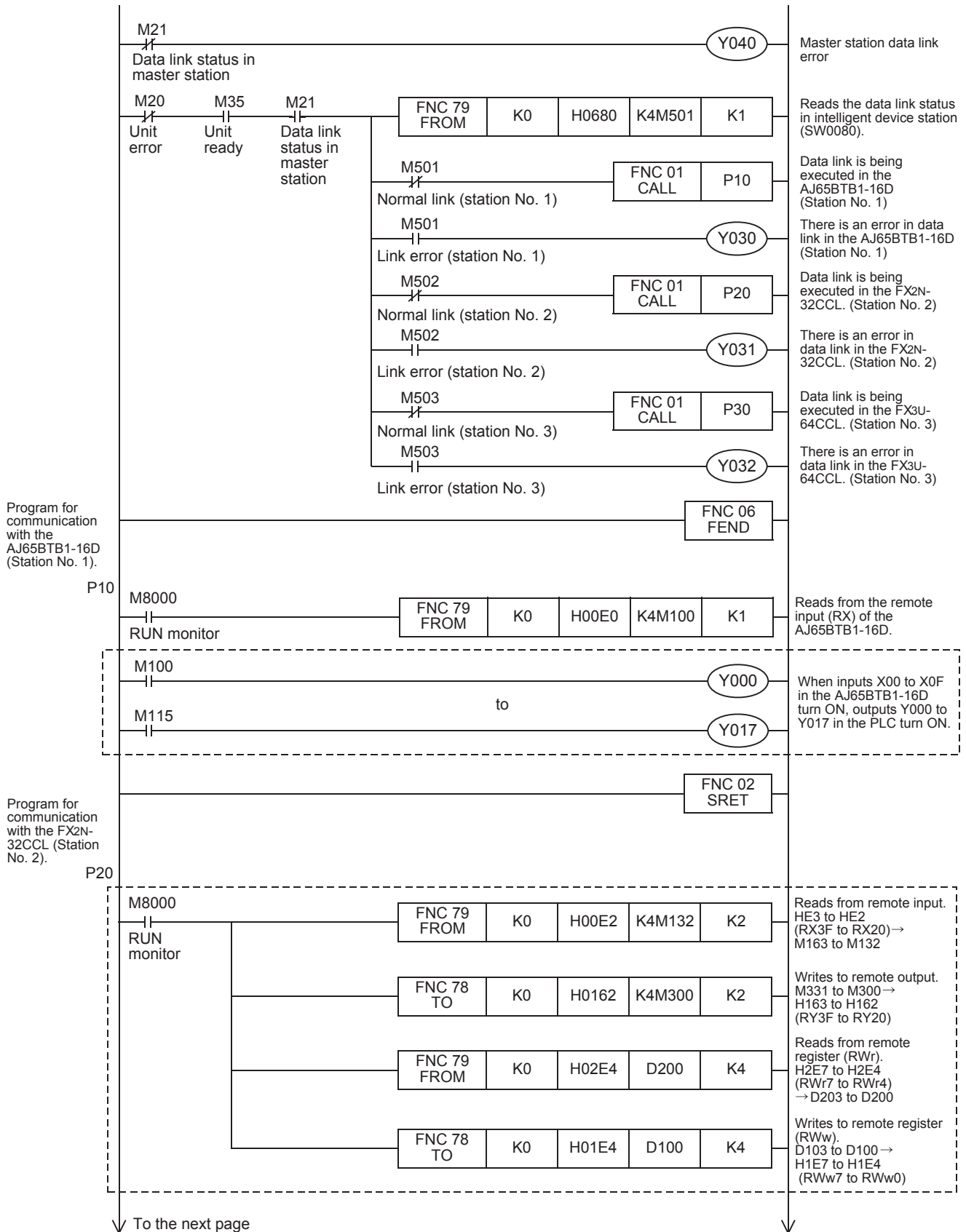

11	Programming
12	Remote I/O Communication Example
13	Remote Device Communication Example
14	Int. Device Communication Example
15	Compound Sys. Communication Example
16	Troubleshooting
A	Version Information
B	Setting Sheet
C	Differences with FX2N-16CCL-M

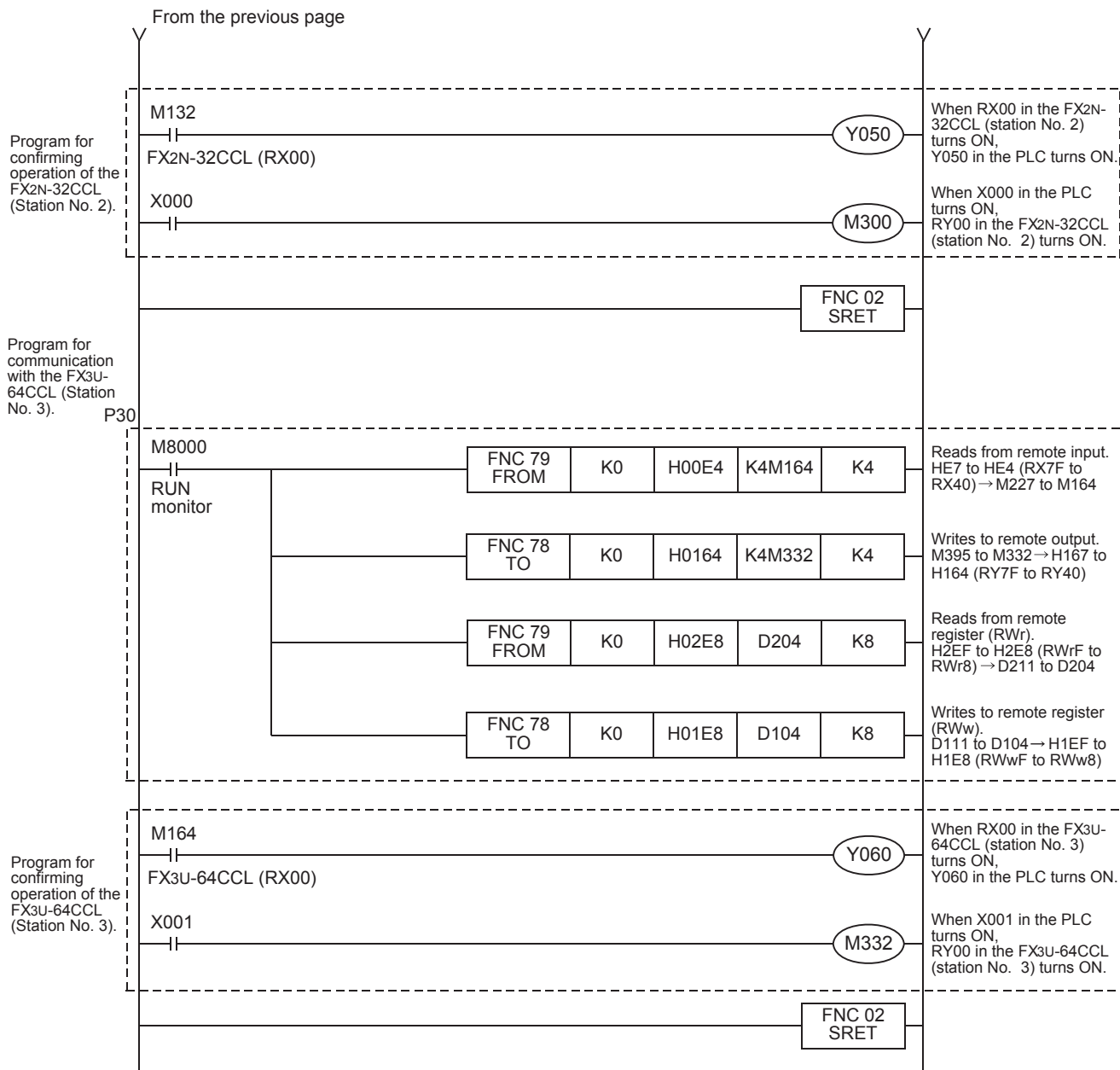

15.1.8 Execution of data link

Turn on the power of the units in the order "remote I/O station, remote device station, intelligent device station → master station", then start the data link.

15.1.9 Confirmation of operation by LED indication

The figures below show the LED indication status in the master station, the remote I/O station, the remote device station and intelligent device station while the data link is normally proceeding.

- LED indication in the master station

Make sure that the LED indication status is as shown below.

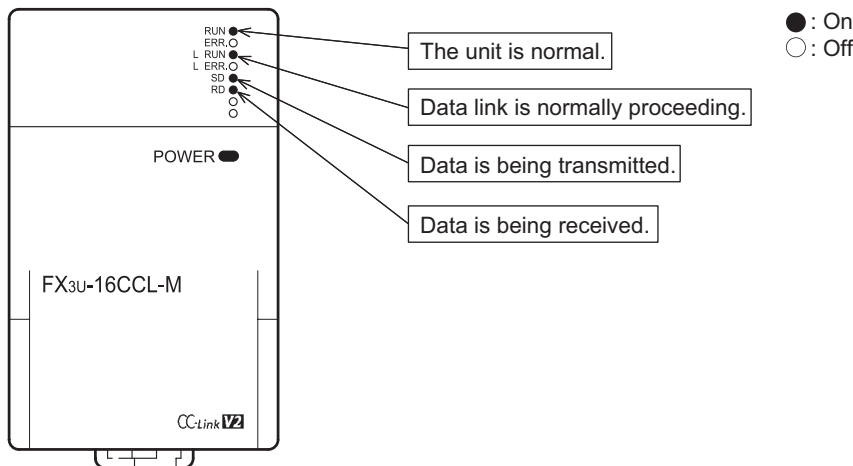

- LED indication in the remote I/O station

Make sure that the LED indication status is as shown below.

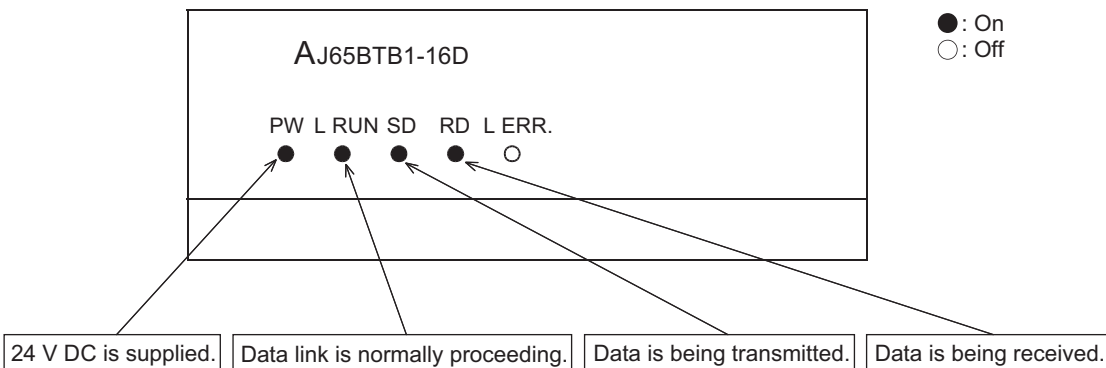

- LED indication in the remote device station

Make sure that the LED indication status is as shown below.

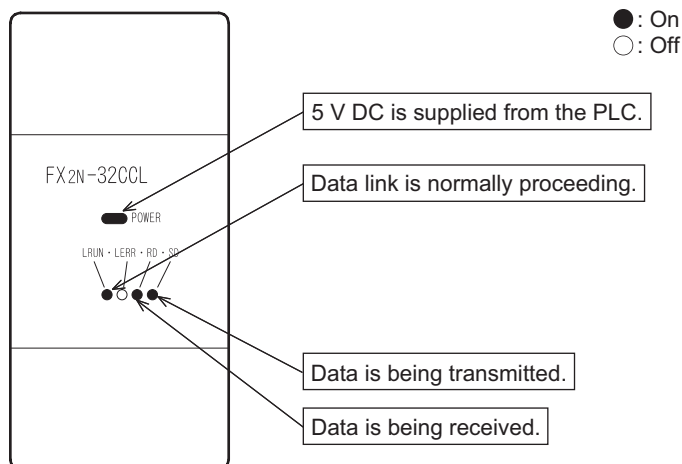

- LED indication in the intelligent device station (FX3U-64CCL)
Make sure that the LED indication status is as shown below.

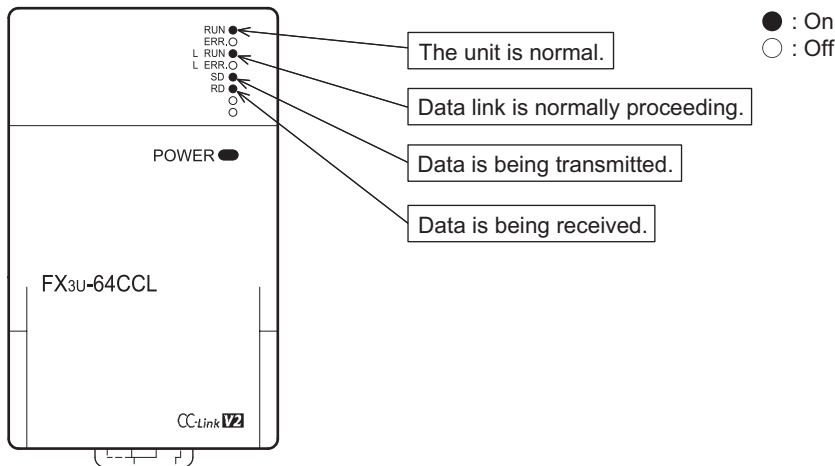

15.1.10 Confirmation of operation by program

Using a sequence program, make sure that data link is normally proceeding.

- When the input X00 in the AJ65BTB1-16D (station No. 1) is set to ON, the output Y000 in the master station PLC turns ON.
- When X000 in the master station PLC turns ON, RY00 in the FX2N-32CCL (station No. 2) turns ON.
- When RX40 in the FX3U-64CCL (station No. 3) turns ON, Y060 (M164) in the master station PLC turns ON.

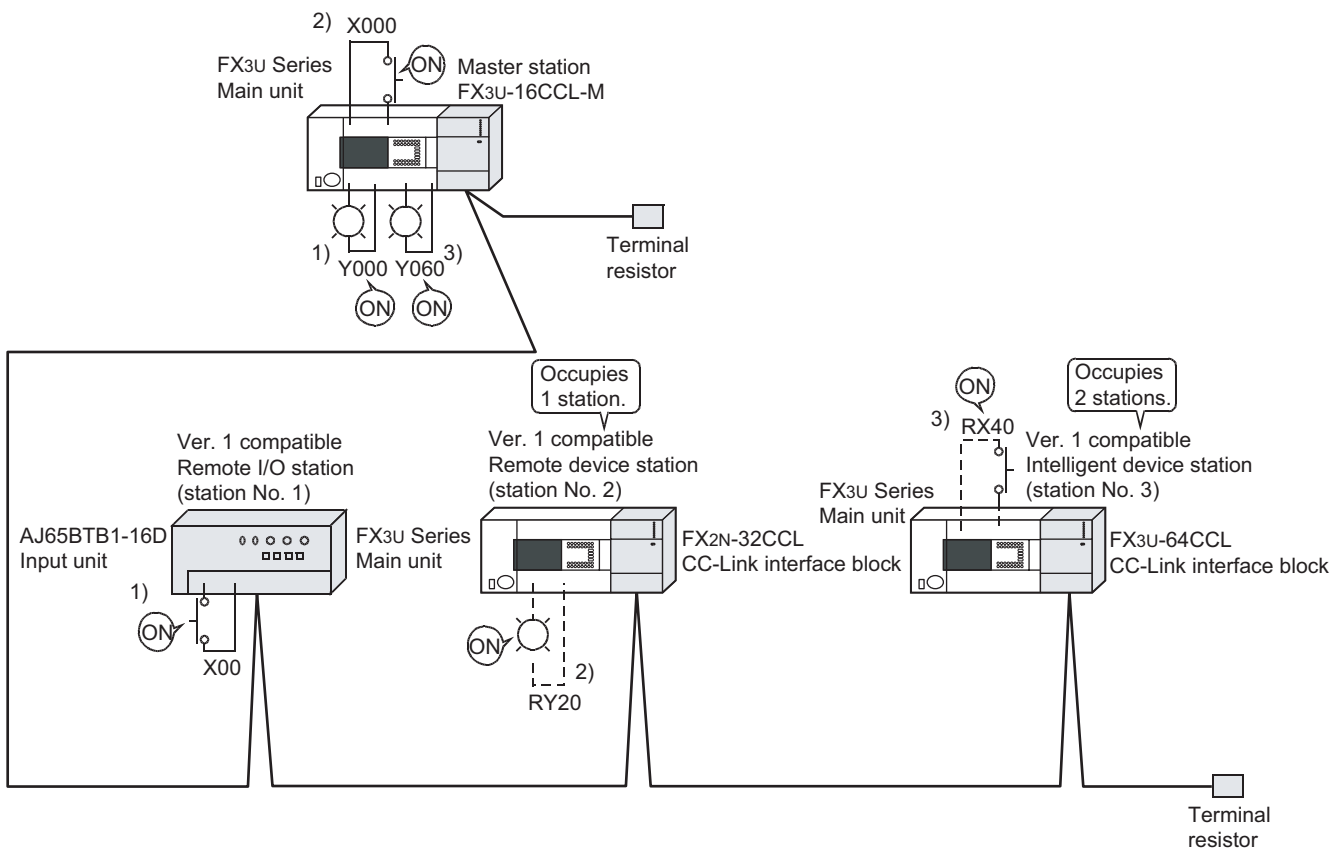

Caution

A program for communication is required also in the FX3U Series main unit connected to the FX2N-32CCL and FX3U-64CCL.

15.2 When Remote Net Ver. 2 Mode is Used

15.2.1 System configuration

It is supposed that one remote I/O station, one remote device station (FX2N-32CCL) and one intelligent device station (FX3U-64CCL) are connected in the system.

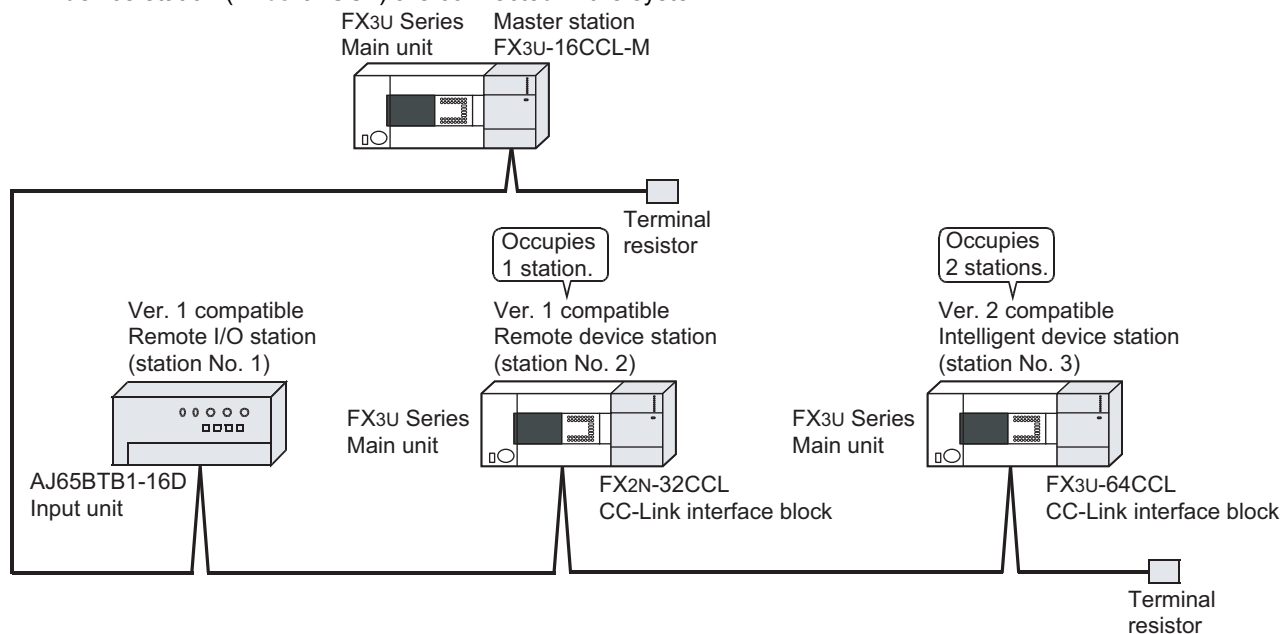

15.2.2 Setting of master station

The figure below shows the setting of the switches in the master station.

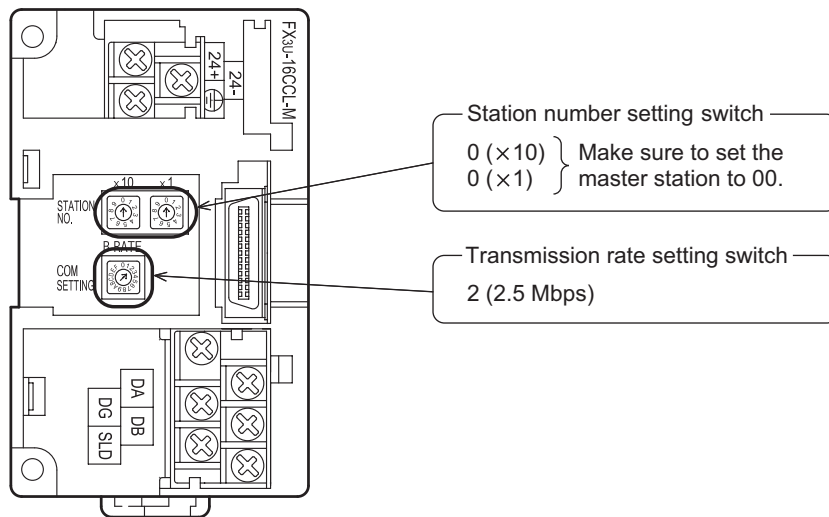

11

Programming

12

Remote I/O
Communication
Example

13

Remote Device
Communication
Example

14

Int. Device
Communication
Example

15

Compound Sys.
Communication
Example

16

Troubleshooting

A

Version
Information

B

Setting Sheet

C

Differences with
FX2N-16CCL-M

15.2.3 Setting of remote I/O station

The figure below shows the setting of the switches in the remote I/O station.

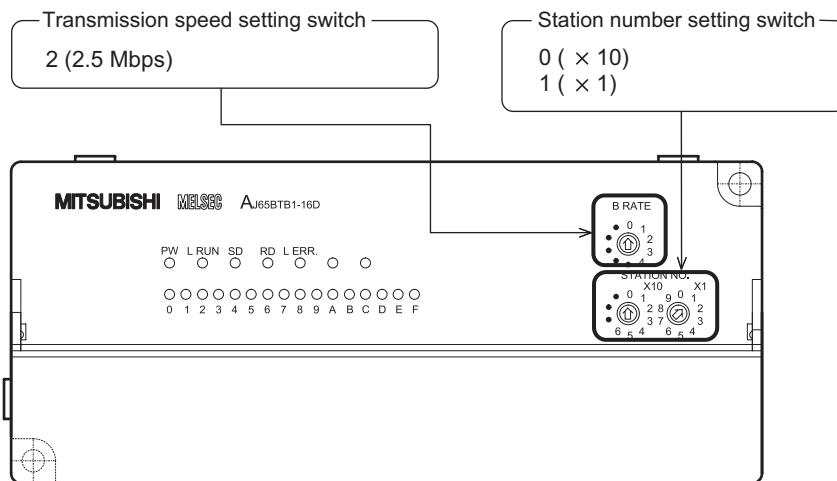

15.2.4 Setting of remote device station

The figure below shows the setting of the switches in the remote device station.

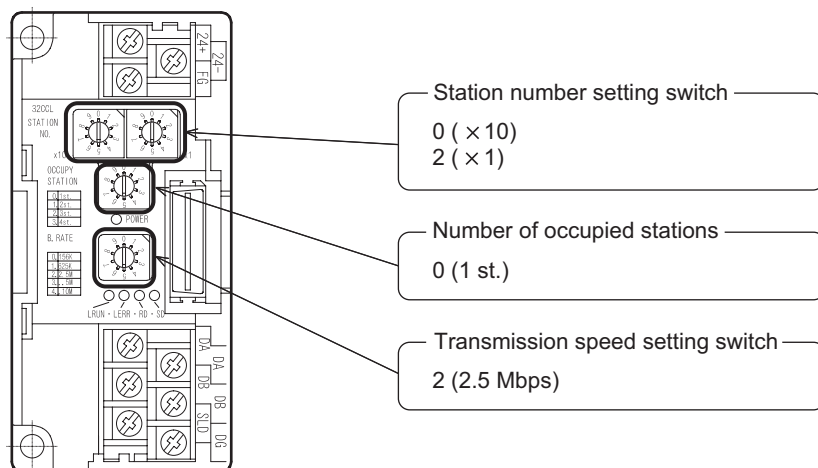

15.2.5 Setting of intelligent device station

The figure below shows the setting of the switches in the intelligent device station.

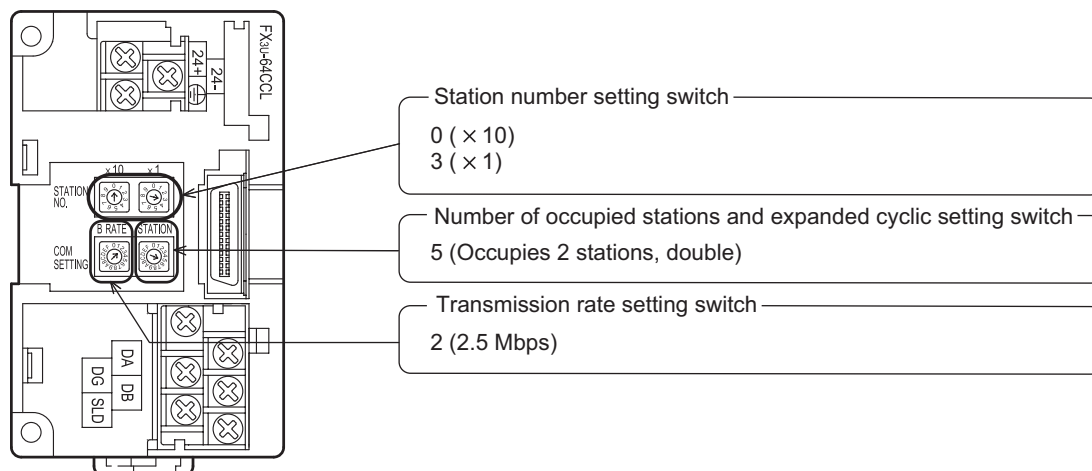

15.2.6 Setting of parameters

This Subsection describes parameter setup for performing a data link. This subsection describes parameter setup for performing data link using a sequence program. Refer to Section 8.5 for the setting method using network parameters. The program for parameters shown below is not required when parameters are set using network parameters.

1. Program for parameters

In the program below, data link automatically starts when the PLC starts to run.

Caution

The auxiliary relays in the non-keep area must be used as auxiliary relays (M) for parameter setting programs.

→ For the precautions in programming, refer to Section 11.1.

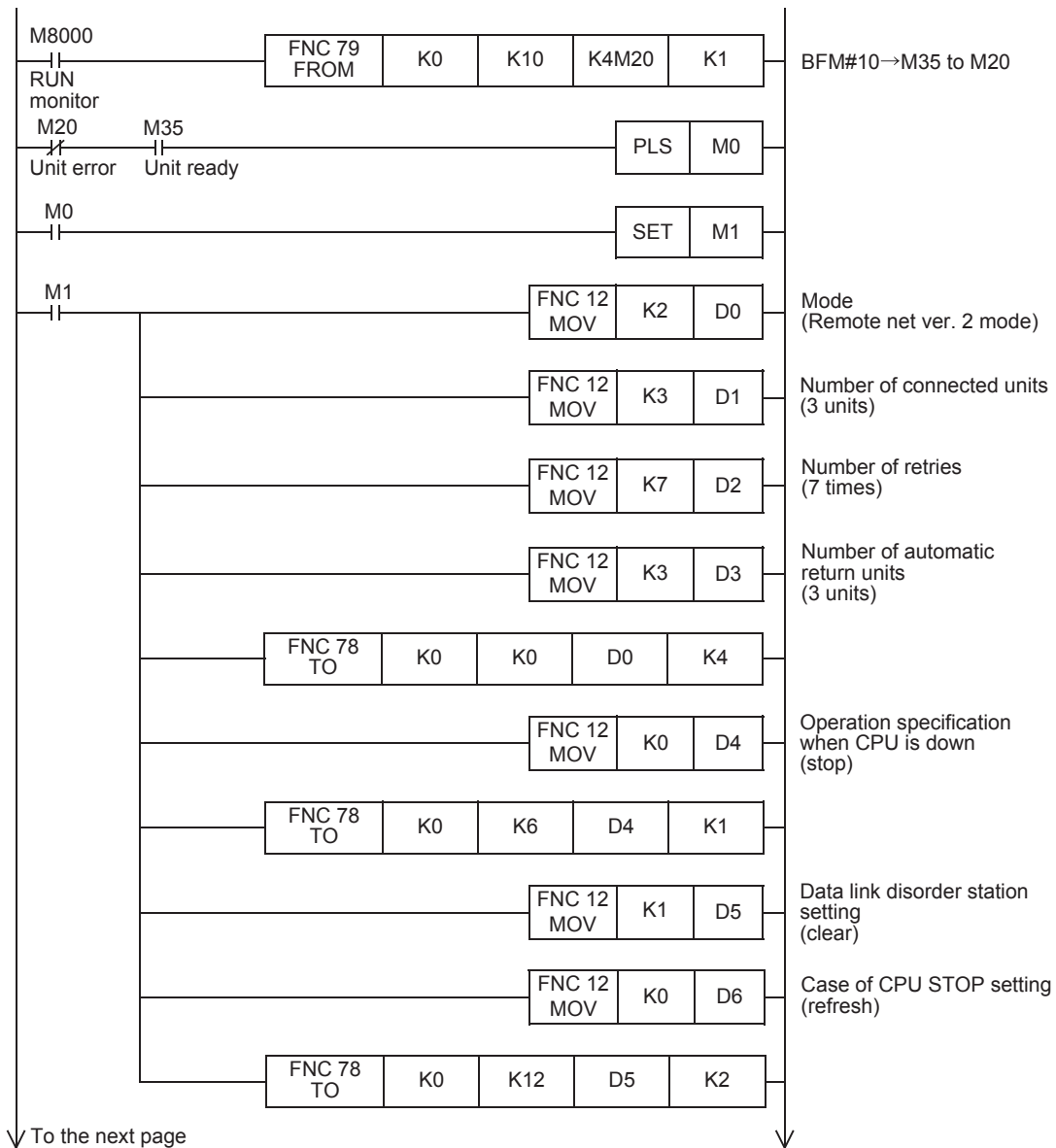

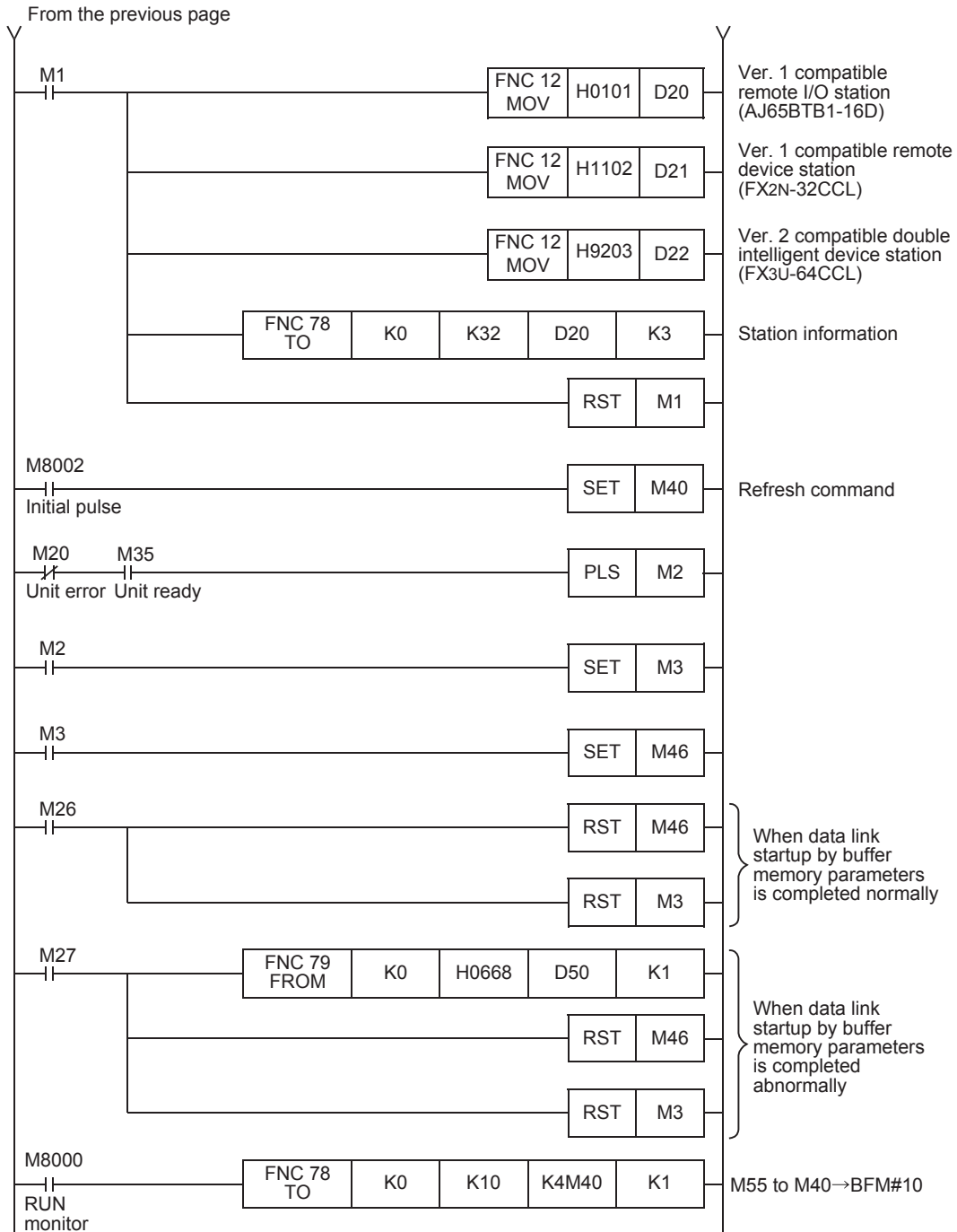

15.2.7 Creating a program for communication

This Subsection describes a program to control remote I/O stations, remote device stations and intelligent device stations.

- The relationship among the PLC, the master station buffer memory, remote I/O stations, remote device stations and intelligent device stations.
 - Remote input (RX) and remote output (RY)

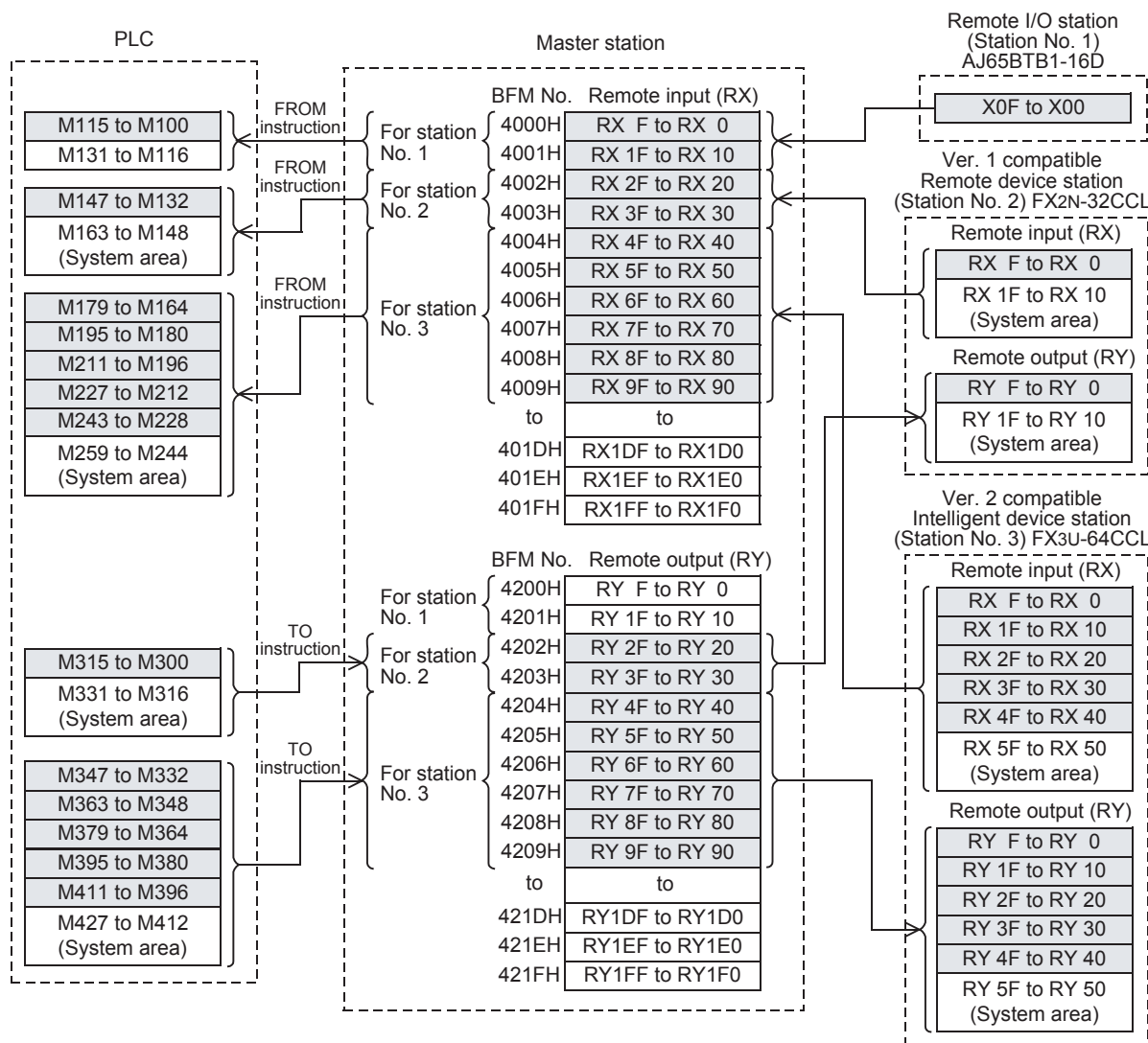

11	Programming
12	Remote I/O Communication Example
13	Remote Device Communication Example
14	Int. Device Communication Example
15	Compound Sys. Communication Example
16	Troubleshooting
A	Version Information
B	Setting Sheet
C	Differences with FX2N-16CCL-M

- Remote register (RWw, RWr)

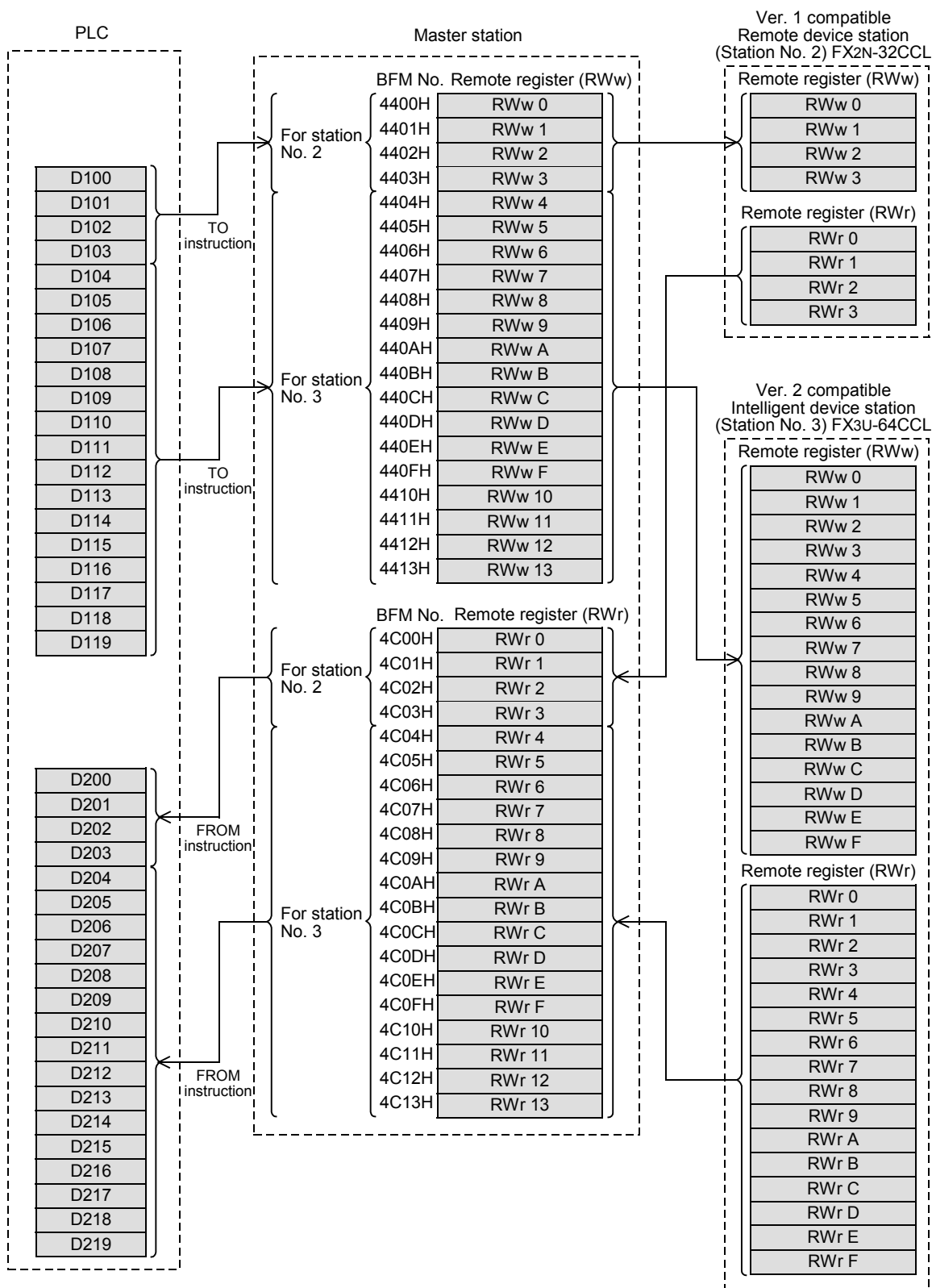

- Program to control remote I/O stations, remote device stations and intelligent device stations

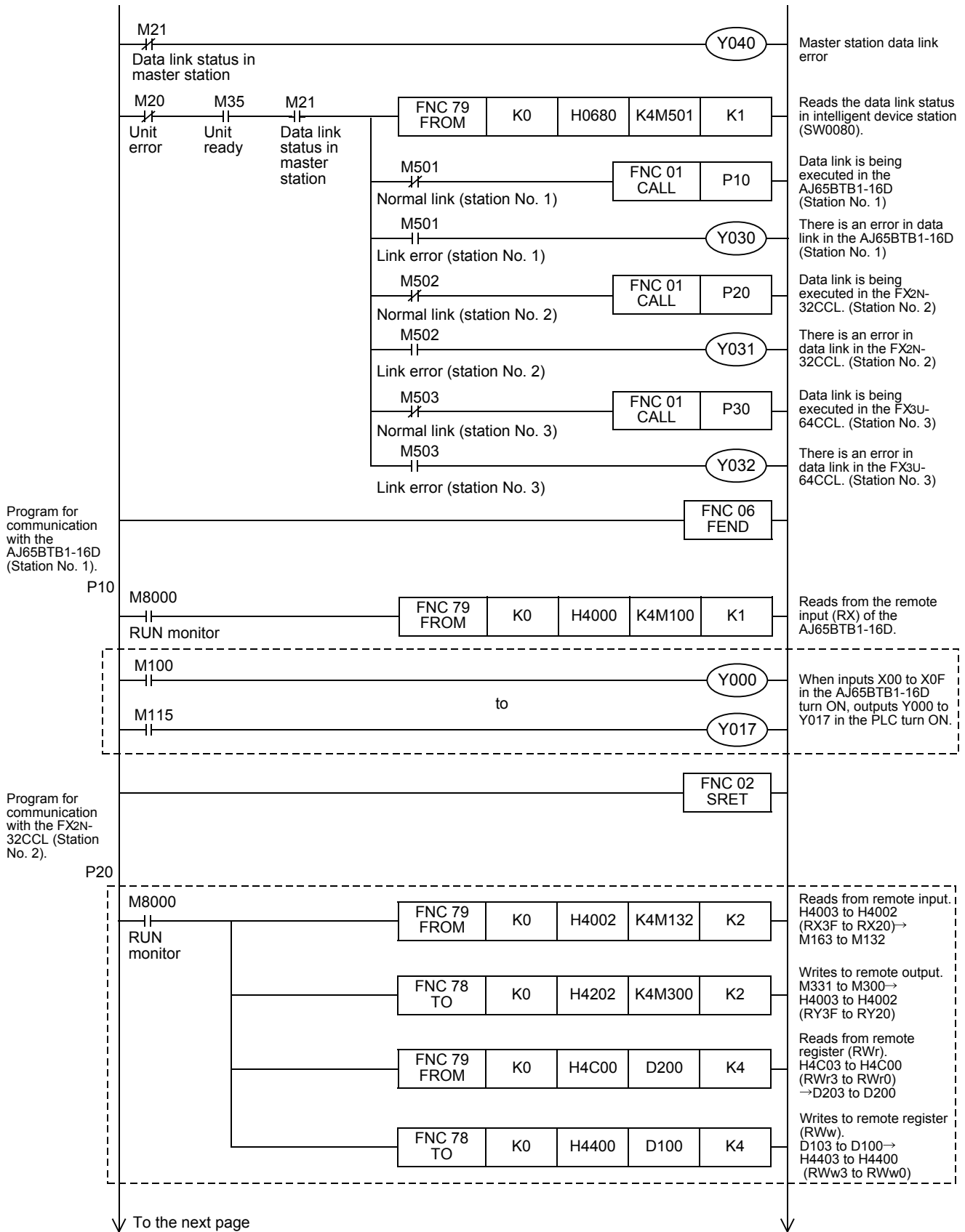

↓ To the next page

11	Programming
12	Remote I/O Communication Example
13	Remote Device Communication Example
14	Int. Device Communication Example
15	Compound Sys. Communication Example
16	Troubleshooting
A	Version Information
B	Setting Sheet
C	Differences with FX2N-16CCL-M

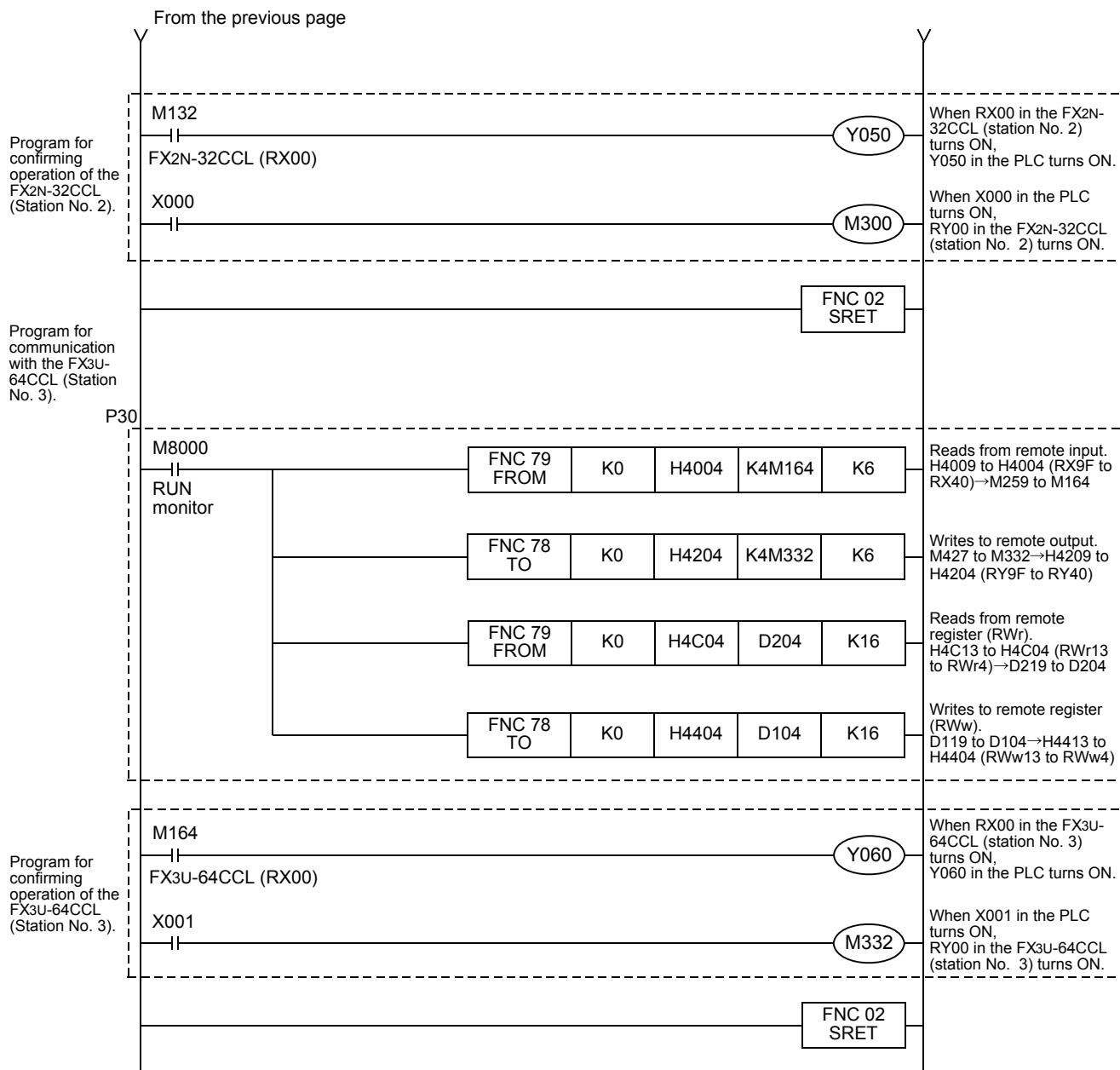

15.2.8 Execution of data link

Turn on the power of the units in the order "remote I/O station, remote device station, intelligent device station → master station", then start the data link.

15.2.9 Confirmation of operation by LED indication

The figures below show the LED indication status in the master station, the remote I/O station, the remote device station and intelligent device station while the data link is normally proceeding.

- LED indication in the master station

Make sure that the LED indication status is as shown below.

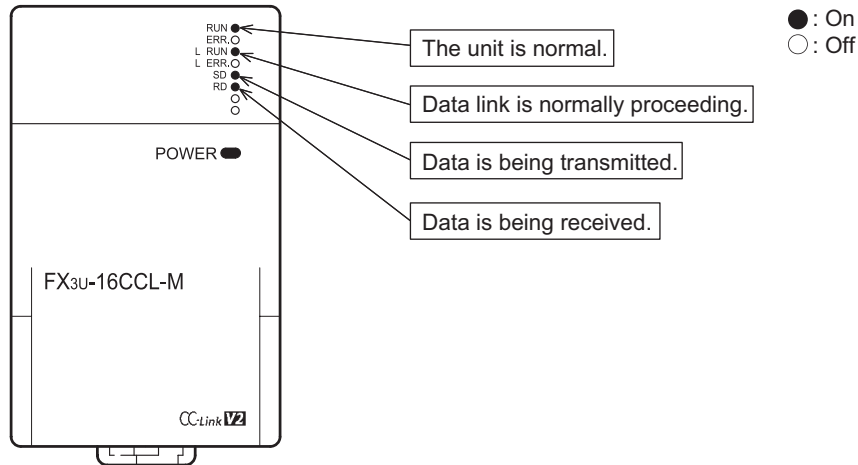

- LED indication in the remote I/O station

Make sure that the LED indication status is as shown below.

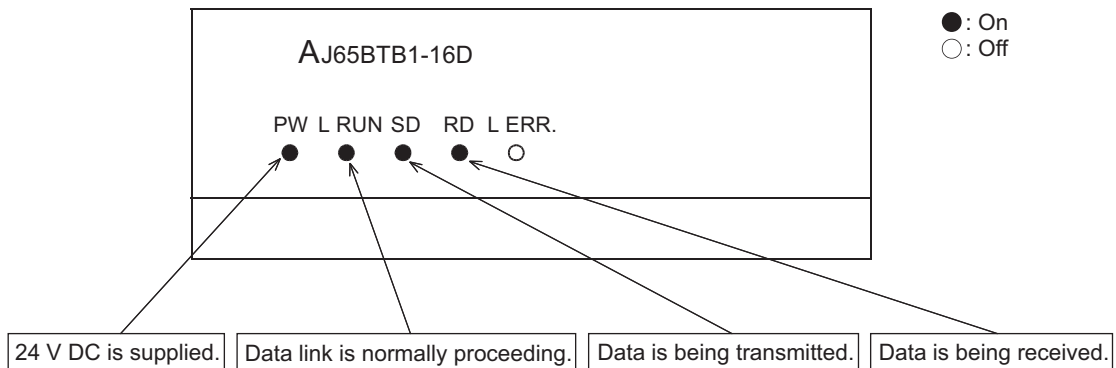

- LED indication in the remote device station

Make sure that the LED indication status is as shown below.

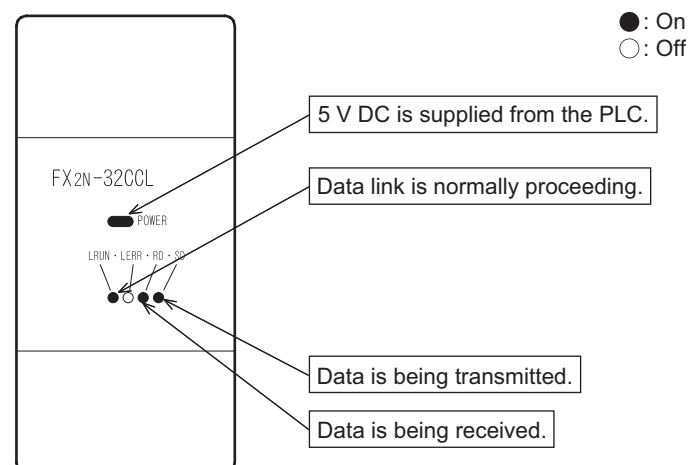

11

Programming

12

Remote I/O
Communication
Example

13

Remote Device
Communication
Example

14

Int. Device
Communication
Example

15

Compound Sys.
Communication
Example

16

Troubleshooting

A

Version
Information

B

Setting Sheet

C

Differences with
FX2N-16CCL-M

- LED indication in the intelligent device station (FX3U-64CCL)
Make sure that the LED indication status is as shown below.

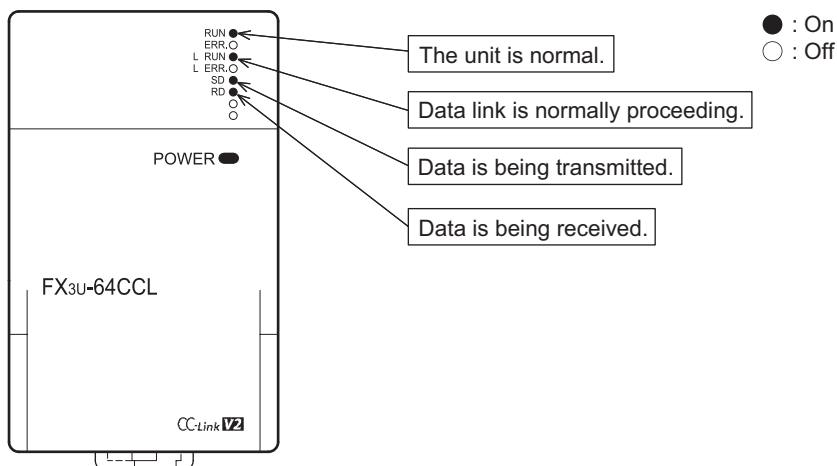

15.2.10 Confirmation of operation by program

Using a sequence program, make sure that data link is normally proceeding.

- When the input X00 in the AJ65BTB1-16D (station No. 1) is set to ON, the output Y000 in the master station PLC turns ON.
- When X000 in the master station PLC turns ON, RY00 in the FX2N-32CCL (station No. 2) turns ON.
- When RX40 in the FX3U-64CCL (station No. 3) turns ON, Y060 (M164) in the master station PLC turns ON.

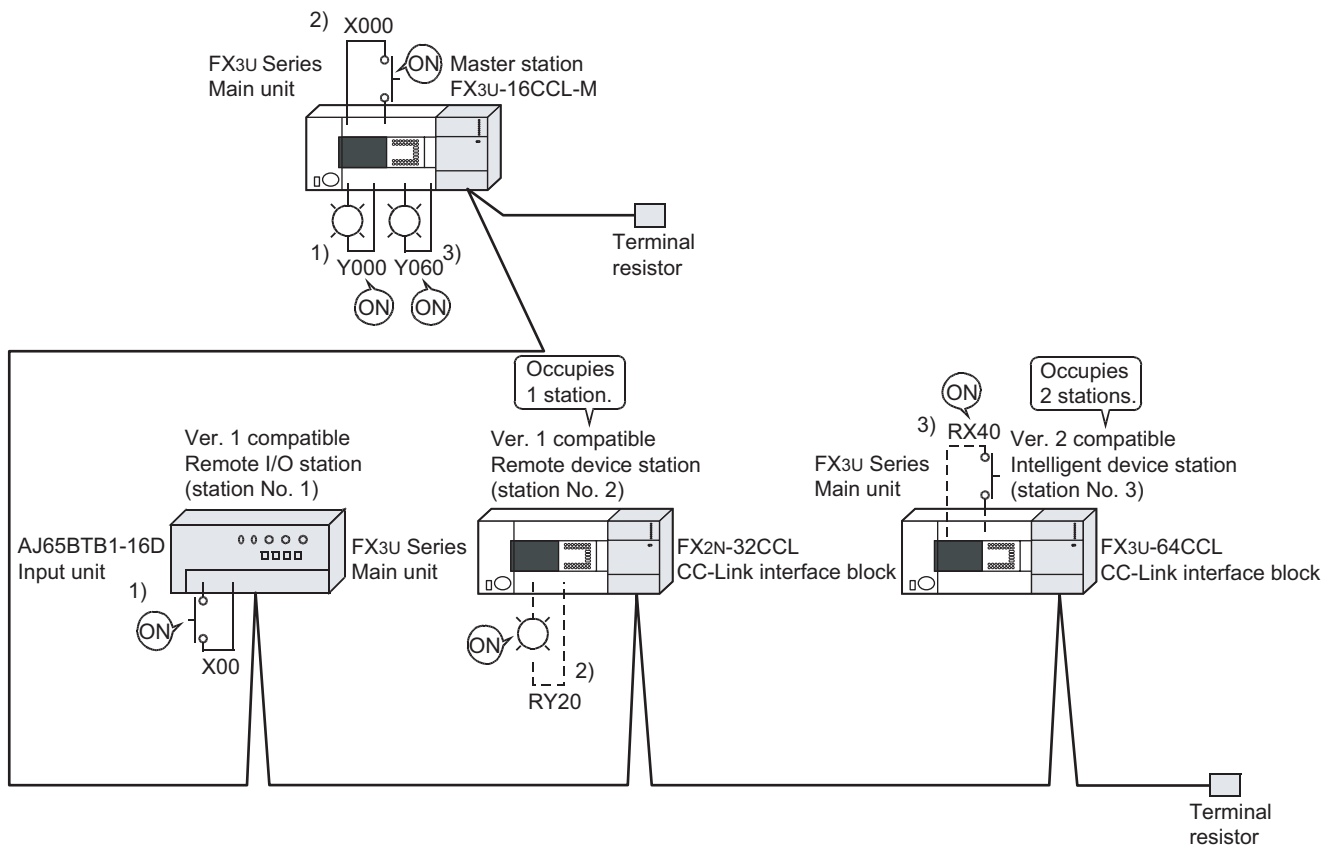

Caution

A program for communication is required also in the FX3U Series main unit connected to the FX2N-32CCL and FX3U-64CCL.

15.3 When Remote Net Additional Mode is Used

15.3.1 System configuration

It is supposed that one remote I/O station, one remote device station (FX2N-32CCL) and one intelligent device station (FX3U-64CCL) are connected in the system.

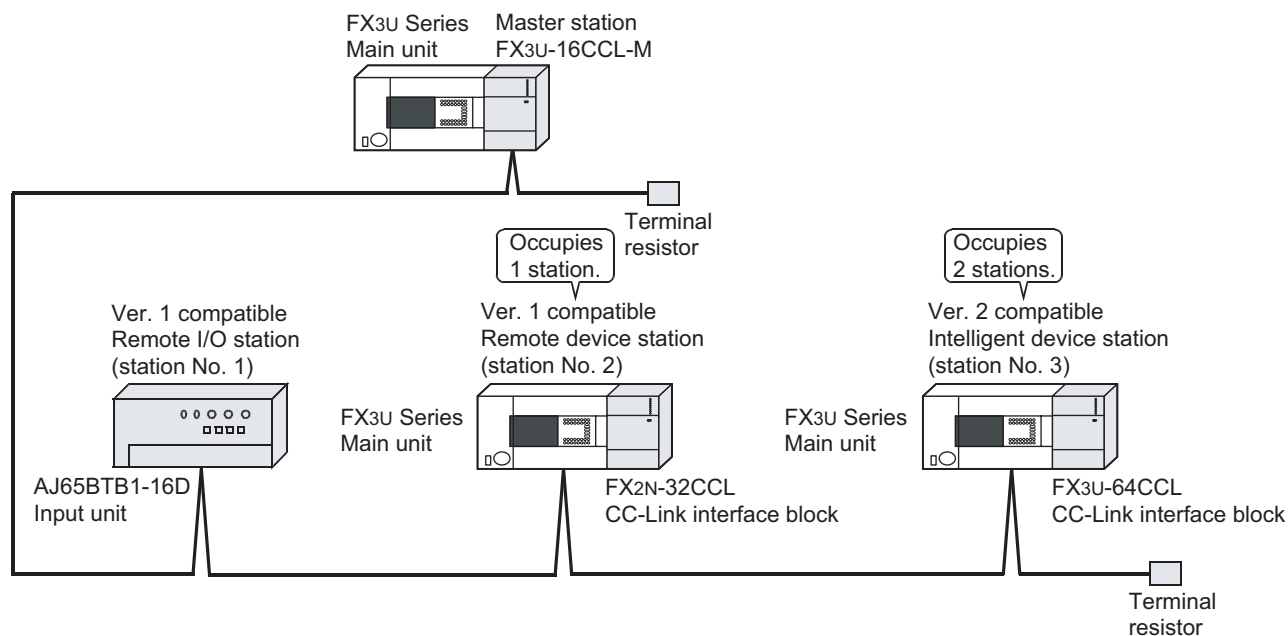

15.3.2 Setting of master station

The figure below shows the setting of the switches in the master station.

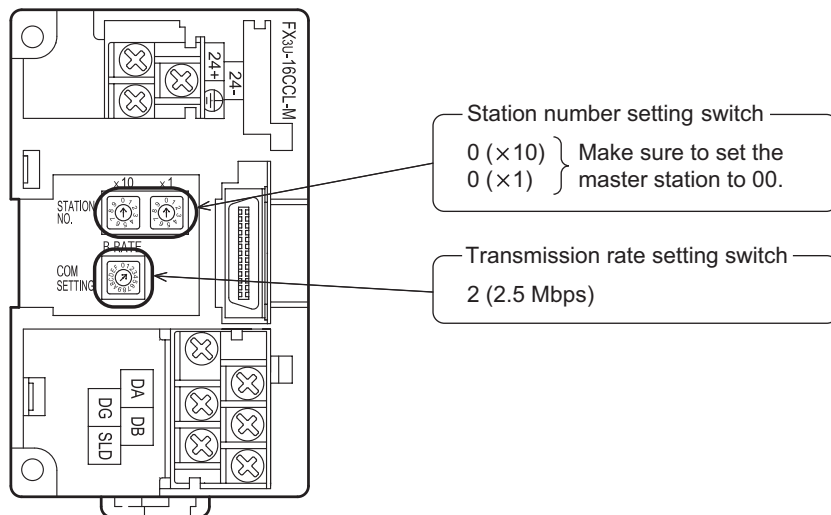

11

Programming

12

Remote I/O
Communication
Example

13

Remote Device
Communication
Example

14

Int. Device
Communication
Example

15

Compound Sys.
Communication
Example

16

Troubleshooting

A

Version
Information

B

Setting Sheet

C

Differences with
FX2N-16CCL-M

15.3.3 Setting of remote I/O station

The figure below shows the setting of the switches in the remote I/O station.

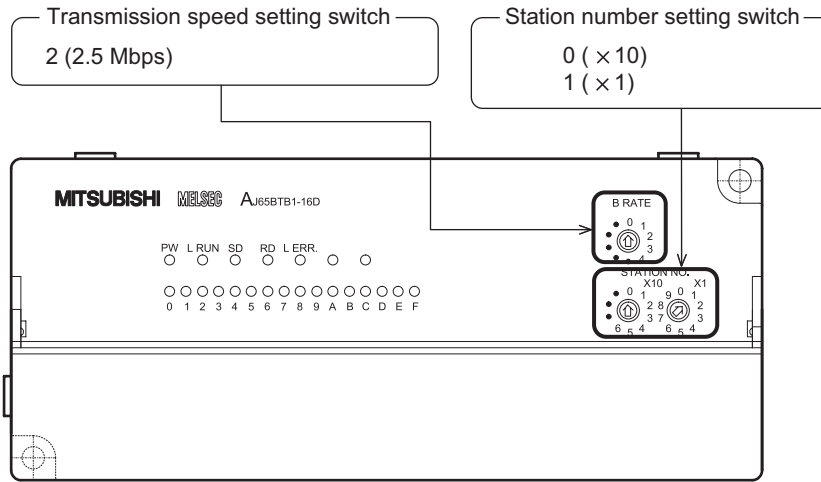

15.3.4 Setting of remote device station

The figure below shows the setting of the switches in the remote device station.

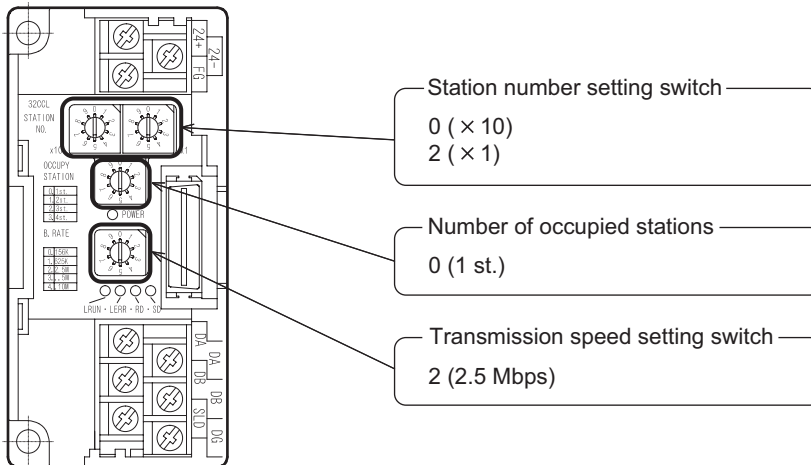

15.3.5 Setting of intelligent device station

The figure below shows the setting of the switches in the intelligent device station.

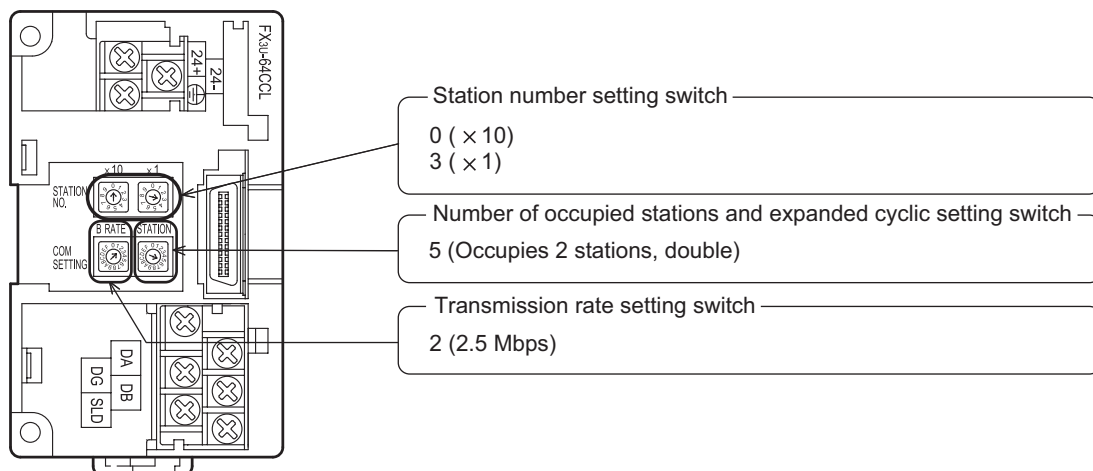

15.3.6 Setting of parameters

This Subsection describes parameter setup for performing a data link. This subsection describes parameter setup for performing data link using a sequence program. Refer to Section 8.5 for the setting method using network parameters. The program for parameters shown below is not required when parameters are set using network parameters.

1. Program for parameters

In the program below, data link automatically starts when the PLC starts to run.

Caution

The auxiliary relays in the non-keep area must be used as auxiliary relays (M) for parameter setting programs.

→ For the precautions in programming, refer to Section 11.1.

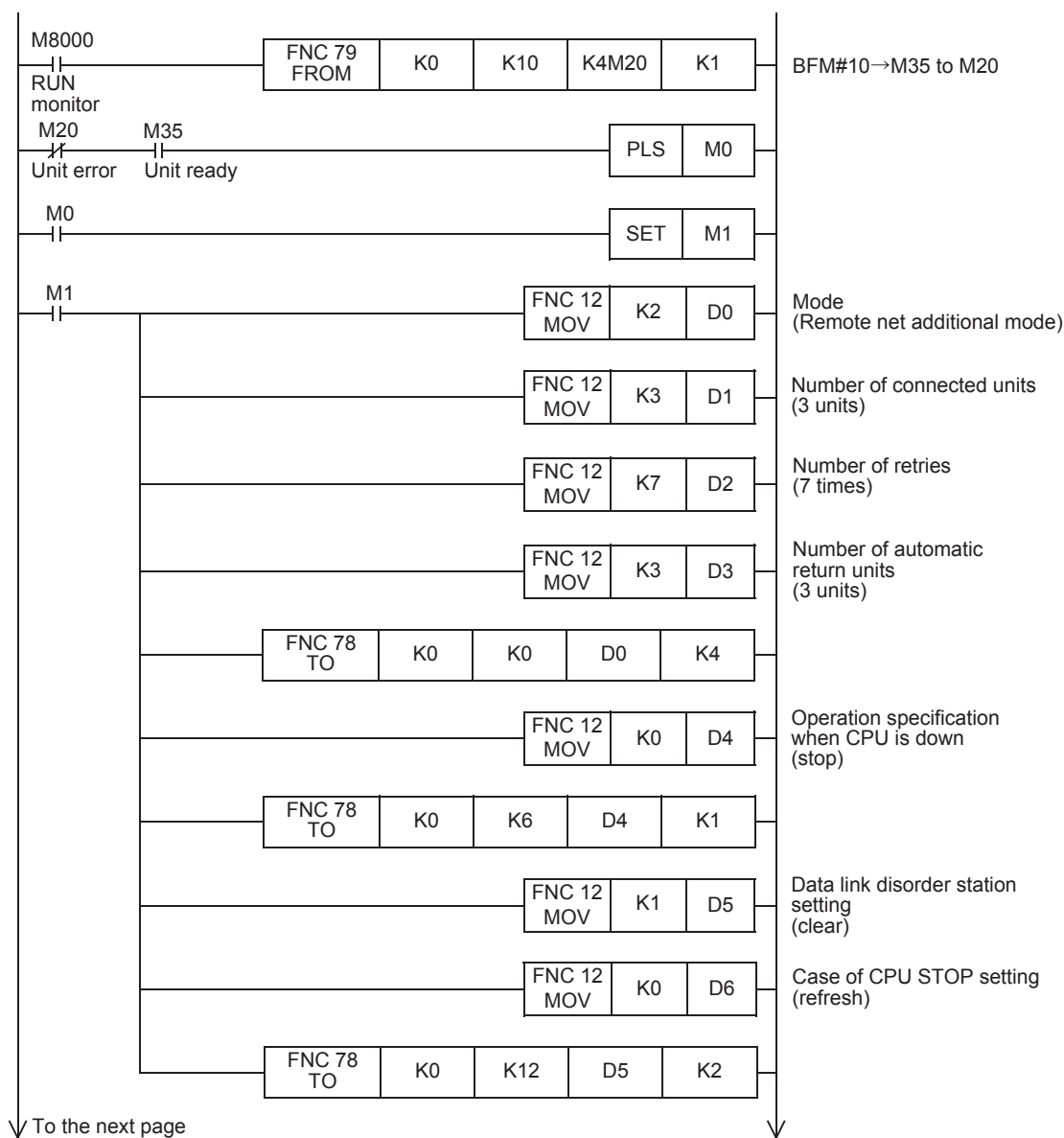

- 11 Programming
- 12 Remote I/O Communication Example
- 13 Remote Device Communication Example
- 14 Int. Device Communication Example
- 15 Compound Sys. Communication Example
- 16 Troubleshooting
- A Version Information
- B Setting Sheet
- C Differences with FX2N-16CCL-M

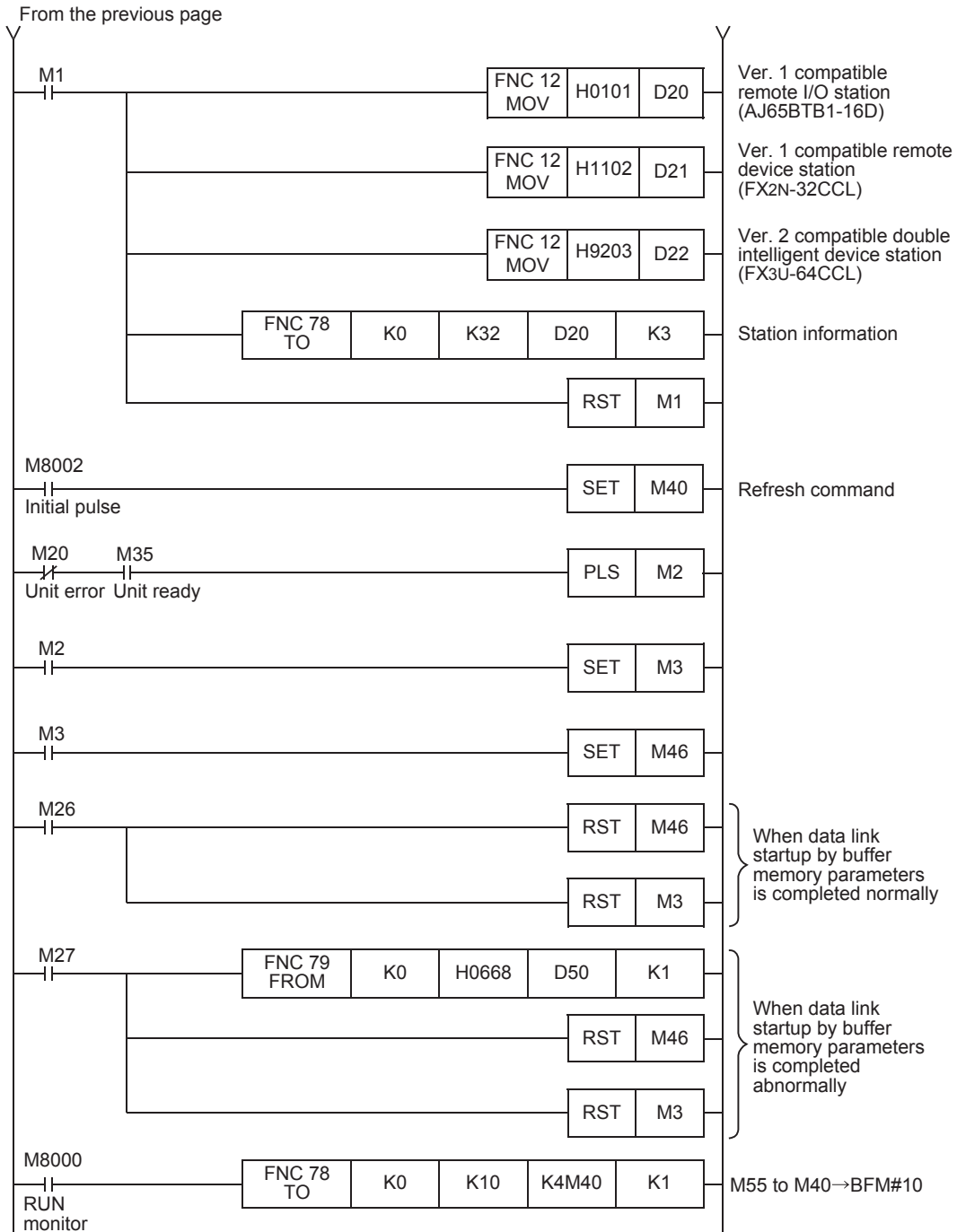

15.3.7 Creating a program for communication

This Subsection describes a program to control remote I/O stations, remote device stations and intelligent device stations.

- The relationship among the PLC, the master station buffer memory, remote I/O stations, remote device stations and intelligent device stations.
 - Remote input (RX) and remote output (RY)

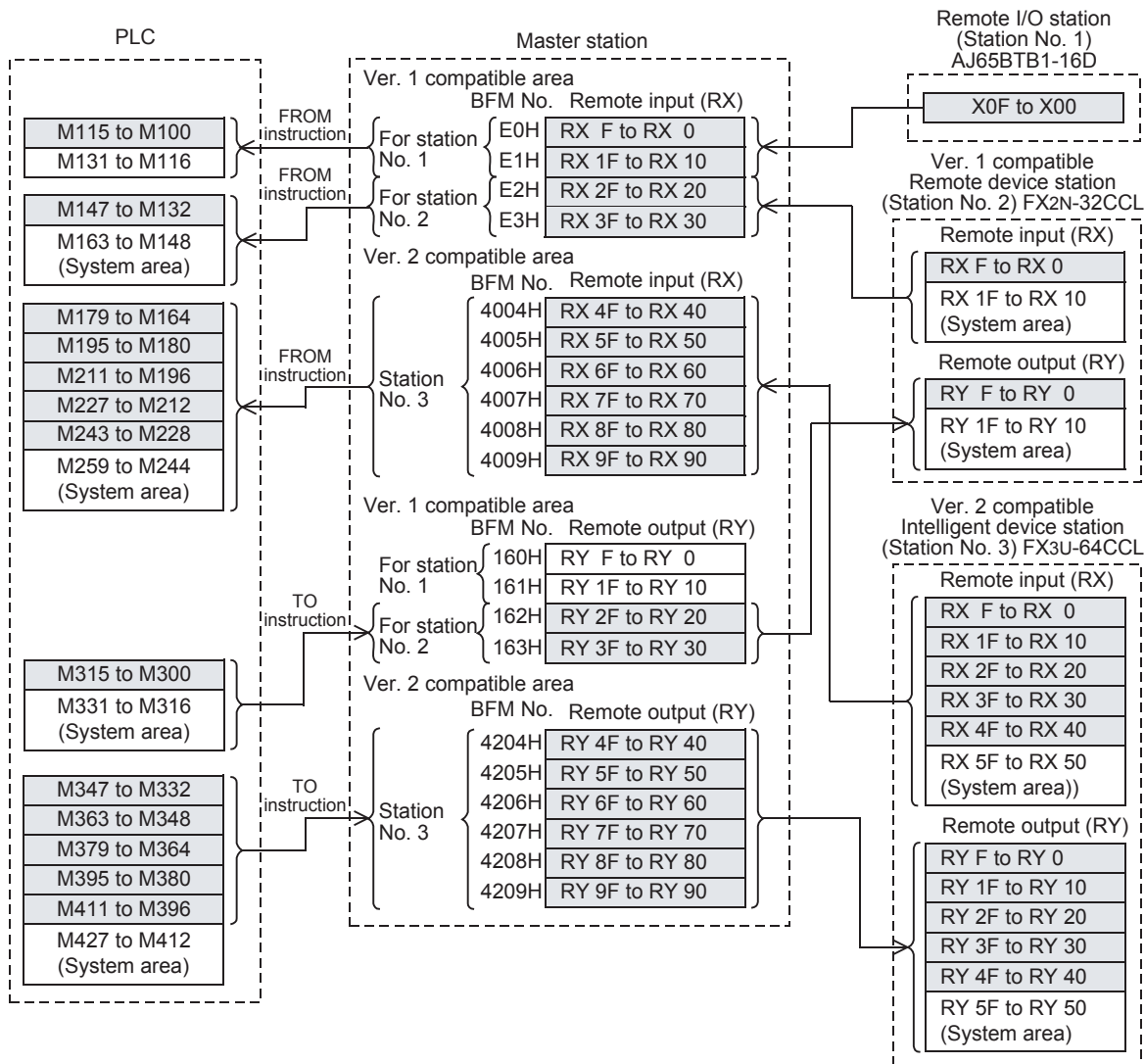

11

Programming

12

Remote I/O
Communication
Example

13

Remote Device
Communication
Example

14

Int. Device
Communication
Example

15

Compound Sys.
Communication
Example

16

Troubleshooting

A

Version
Information

B

Setting Sheet

C

Differences with
FX2N-16CCL-M

- Remote register (RWw, RWr)

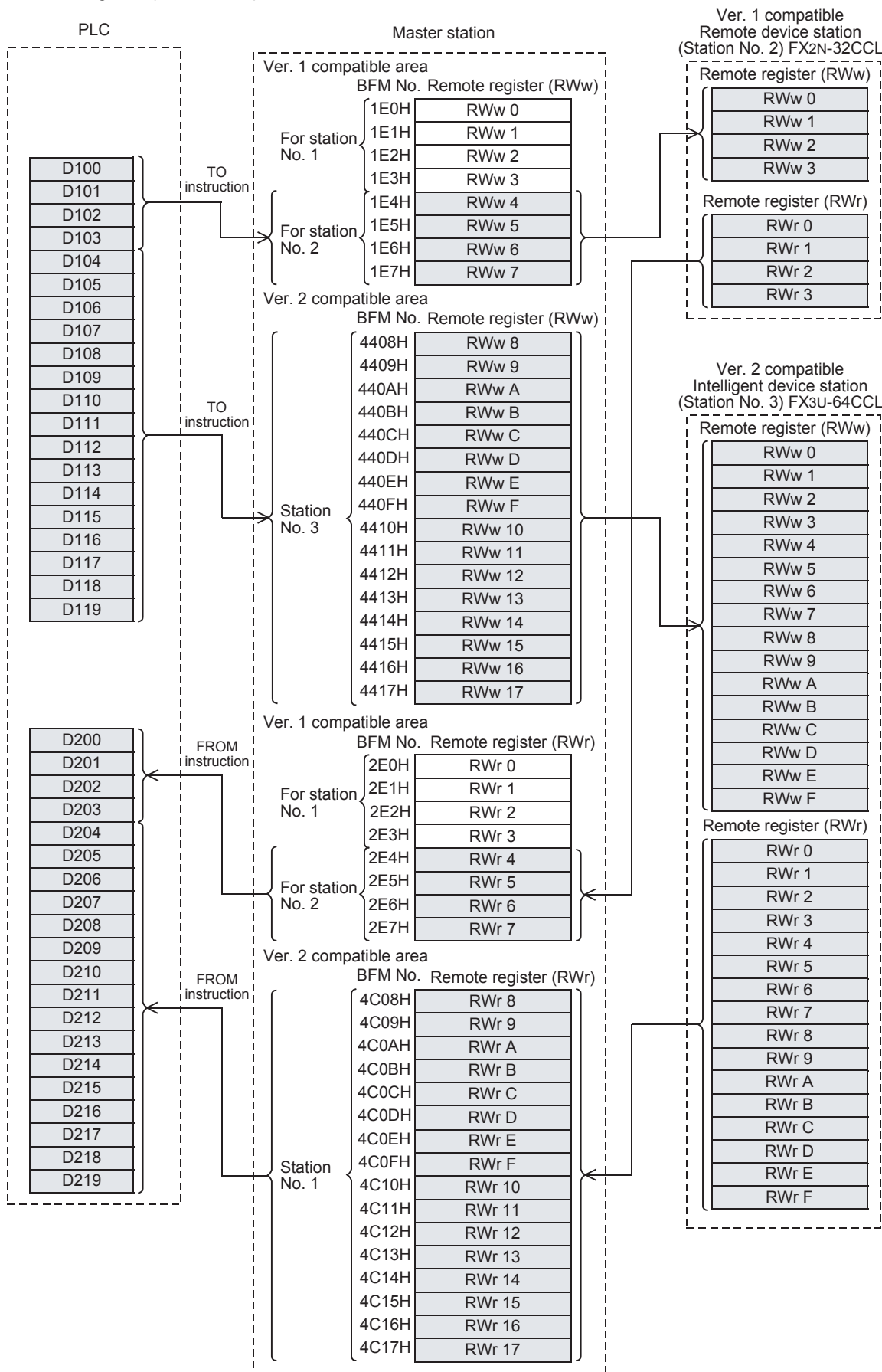

- Program to control remote I/O stations, remote device stations and intelligent device stations

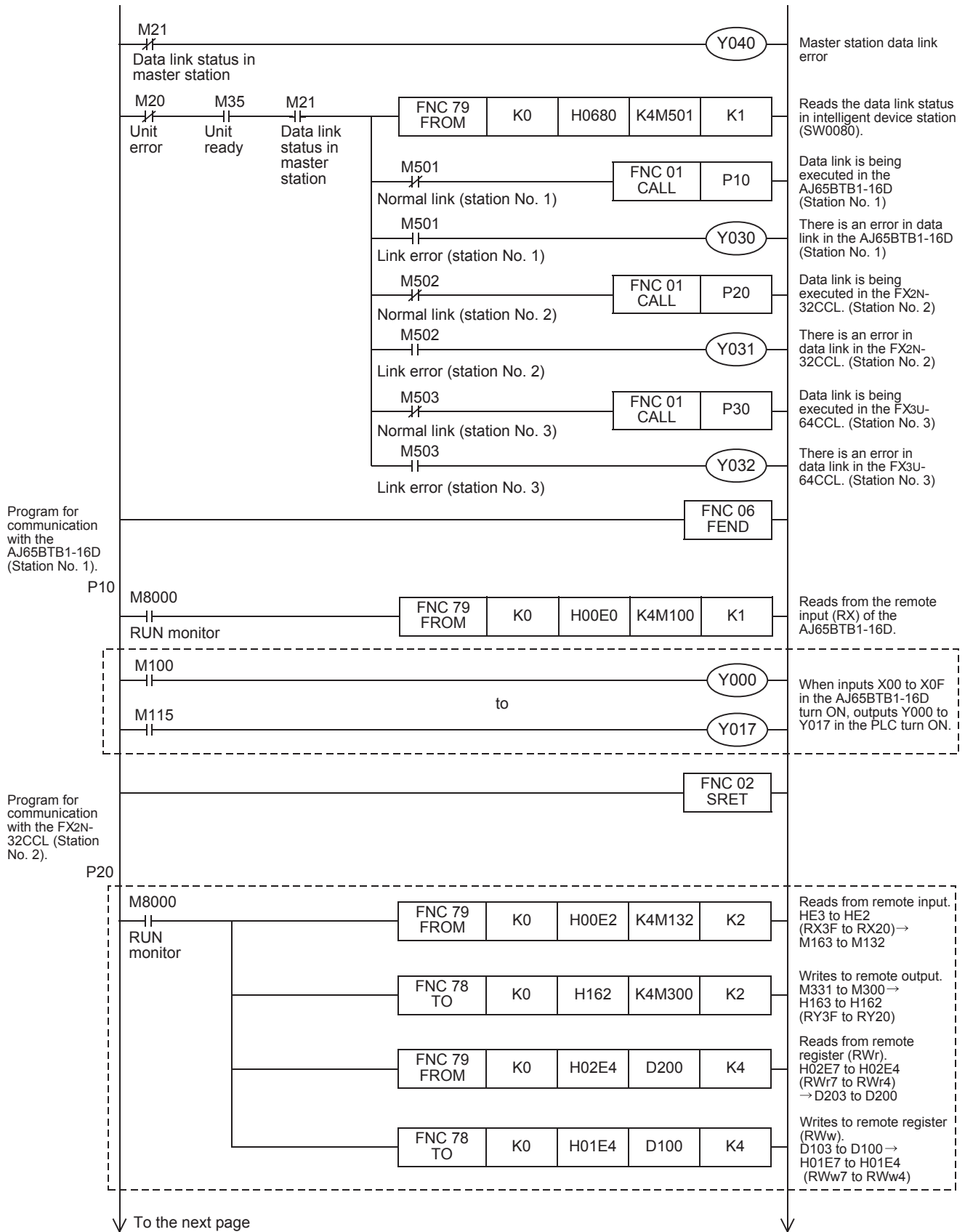

↓ To the next page

11	Programming
12	Remote I/O Communication Example
13	Remote Device Communication Example
14	Int. Device Communication Example
15	Compound Sys. Communication Example
16	Troubleshooting
A	Version Information
B	Setting Sheet
C	Differences with FX2N-16CCL-M

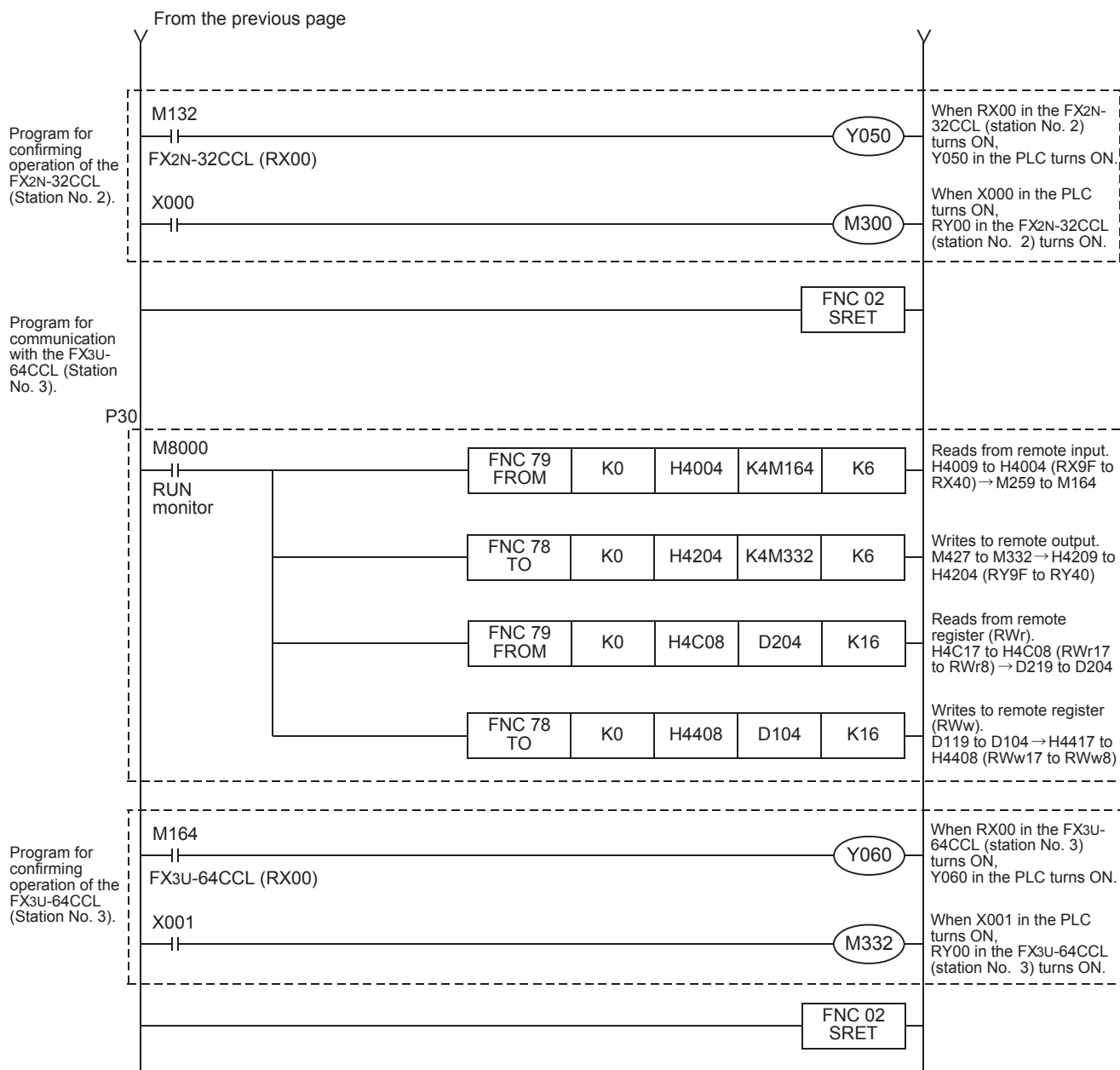

15.3.8 Execution of data link

Turn on the power of the units in the order "remote I/O station, remote device station, intelligent device station → master station", then start the data link.

15.3.9 Confirmation of operation by LED indication

The figures below show the LED indication status in the master station, the remote I/O station, the remote device station and intelligent device station while the data link is normally proceeding.

- LED indication in the master station

Make sure that the LED indication status is as shown below.

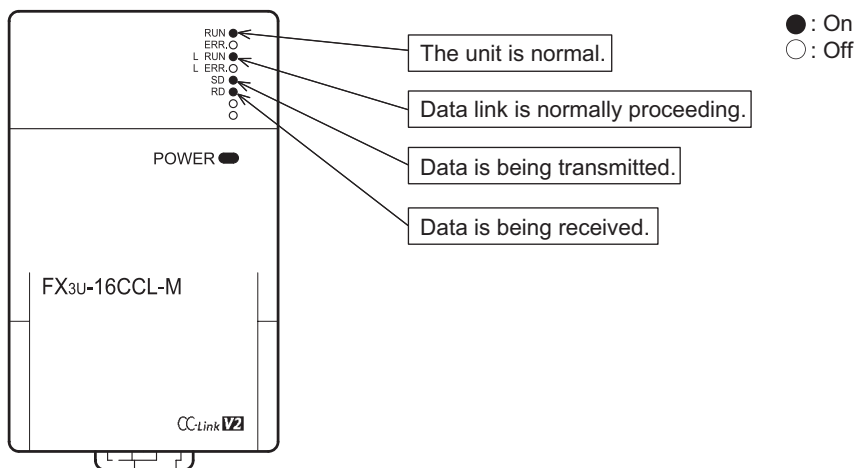

- LED indication in the remote I/O station

Make sure that the LED indication status is as shown below.

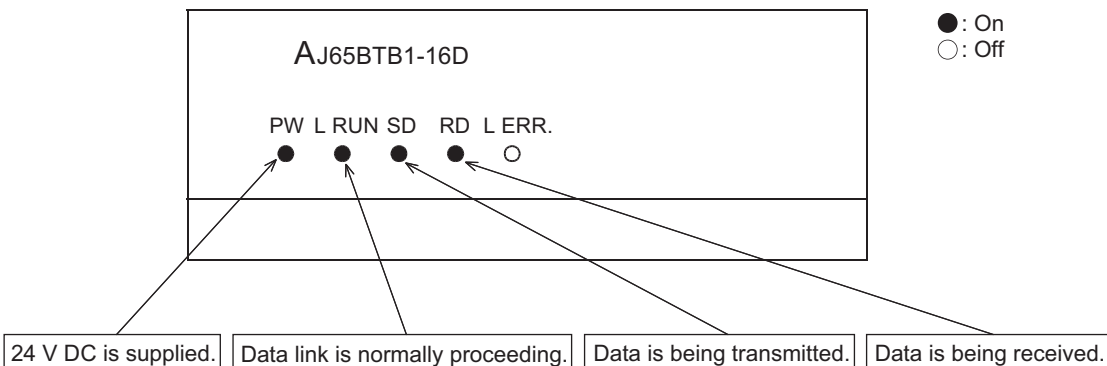

- LED indication in the remote device station

Make sure that the LED indication status is as shown below.

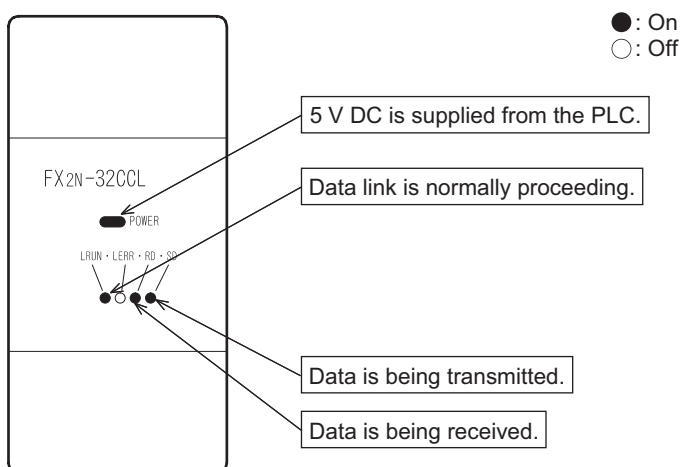

- LED indication in the intelligent device station (FX3U-64CCL)
Make sure that the LED indication status is as shown below.

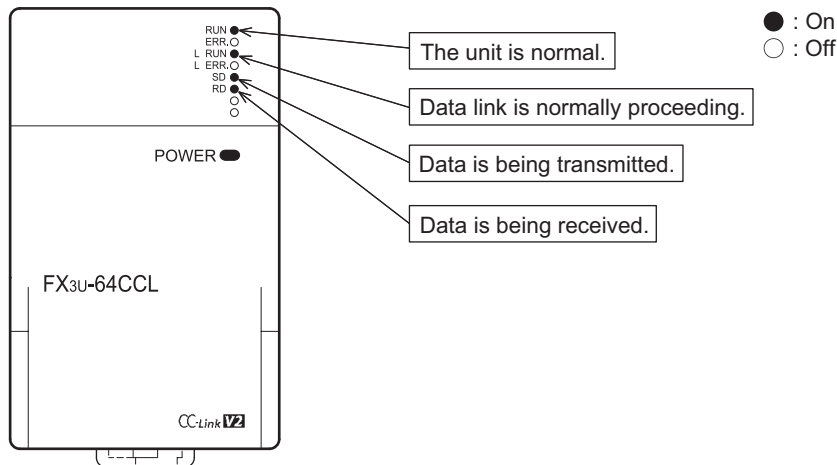

15.3.10 Confirmation of operation by program

Using a sequence program, make sure that data link is normally proceeding.

- When the input X00 in the AJ65BTB1-16D (station No. 1) is set to ON, the output Y000 in the master station PLC turns ON.
- When X000 in the master station PLC turns ON, RY00 in the FX2N-32CCL (station No. 2) turns ON.
- When RX40 in the FX3U-64CCL (station No. 3) turns ON, Y060 (M164) in the master station PLC turns ON.

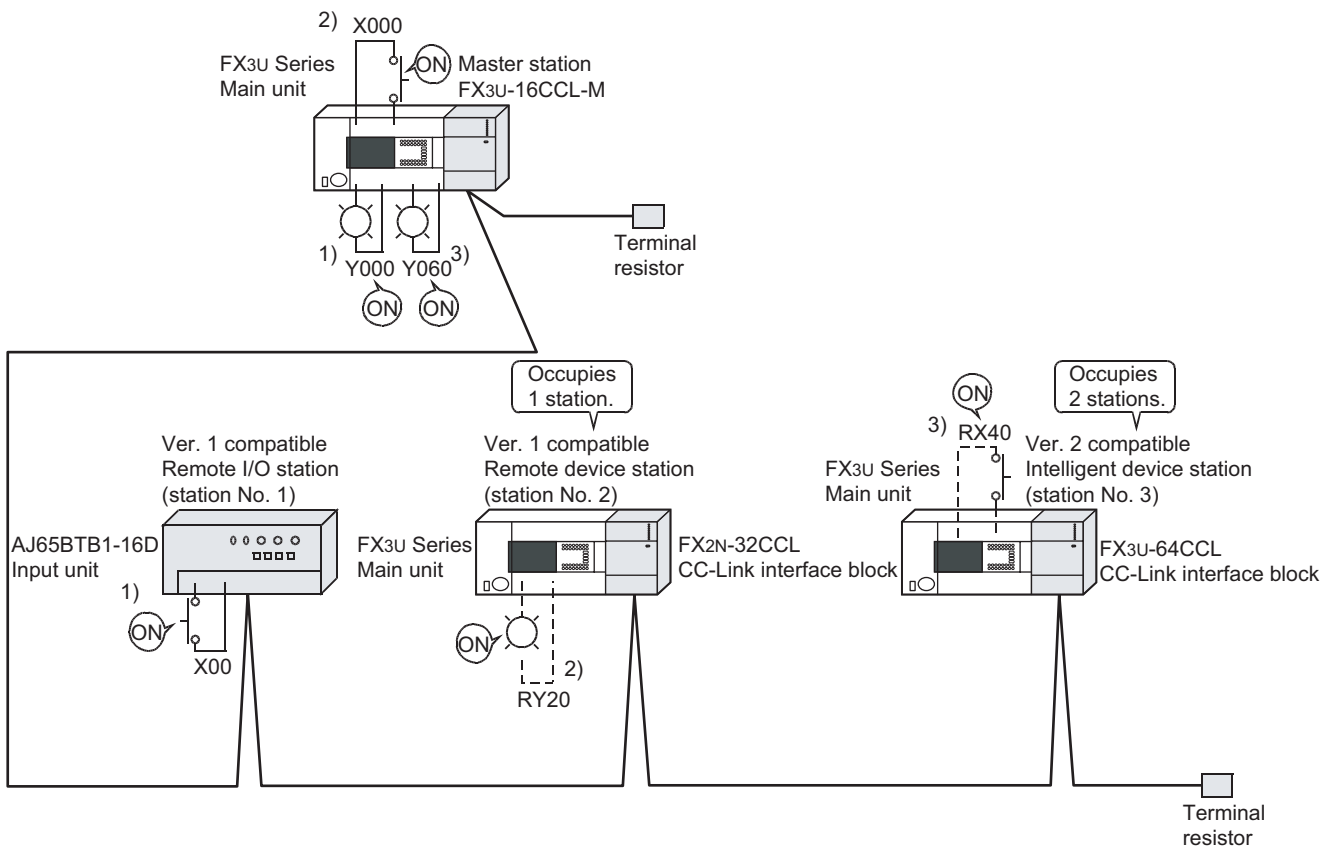

Caution

A program for communication is required also in the FX3U Series main unit connected to the FX2N-32CCL and FX3U-64CCL.

16. Troubleshooting

STARTUP AND MAINTENANCE PRECAUTIONS



- Do not touch any terminal while the PLC's power is on. Doing so may cause electric shock or malfunctions.
- Before cleaning or retightening terminals, cut off all phases of the power supply externally. Failure to do so may cause electric shock.
- Before modifying or disrupting the program in operation or running the PLC, carefully read through this manual and the associated manuals and ensure the safety of the operation. An operation error may damage the machinery or cause accidents.

STARTUP AND MAINTENANCE PRECAUTIONS

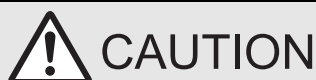

- Do not disassemble or modify the PLC. Doing so may cause fire, equipment failures, or malfunctions. For repair, contact your local Mitsubishi Electric representative.
- Turn off the power to the PLC before connecting or disconnecting any extension cable. Failure to do so may cause equipment failures or malfunctions.
- Turn off the power to the PLC before attaching or detaching the following devices. Failure to do so may cause equipment failures or malfunctions.
 - Peripheral devices, display modules, expansion boards and special adapters
 - I/O extension units/blocks, FX Series terminal block and the special function units/blocks
 - Battery and memory cassette

11

Programming

12

Remote I/O
Communication
Example

13

Remote Device
Communication
Example

14

Int. Device
Communication
Example

15

Compound Sys.
Communication
Example

16

Troubleshooting

A

Version
Information

B

Setting Sheet

C

Differences with
FX2N-16CCL-M

16.1 Troubleshooting procedure

The table below lists the items to be checked and confirmed for each troubleshooting problems.

Trouble description	Details to be checked	Confirmation method
Data link is disabled in the entire system.	Are any cables broken?	Check the cable status visually or by the line test.
	Are terminal resistors connected to the terminal stations located at each end of the CC-Link system?	Connect terminal resistors included as accessories of the FX3U-16CCL-M to stations at the both ends.
	Are correct terminal resistors connected?	Connect the appropriate terminal resistors that match the cable type used for the terminal stations located at each end of the CC-Link system.
	Has an error occurred in the master station?	Check the error code in the PLC, and take the corrective action.
	Are parameters set in the master station?	Confirm the contents of the parameters.
	Is the write request for data link startup (BFM#10 b6) ON?	Confirm the sequence program.
Inputs from a remote I/O station cannot be received.	Has an error occurred in the master station?	Check the following: <ul style="list-style-type: none"> Parameter status in the master station (SW0068) Switch setting status (SW006A) Loading status (SW0069) Flashing of the ERR. LED in the master station.
	Is the remote I/O station executing data link?	Check the following: <ul style="list-style-type: none"> LED indication in the remote I/O station Communication status in the master station with other stations (SW0080)
	Is data read from the correct address of remote input RX (buffer memory)?	Confirm the sequence program.
	Is the corresponding station set as a reserved station?	Check the following: <ul style="list-style-type: none"> Check the parameters. Check the reserved station specified status (SW0074).
	Does the station number overlap?	Check the following: <ul style="list-style-type: none"> Check the station number setting. Check the loading status (SW0069). Check the station number overlap status (SW0098).
	Do the settings match?	Check the following: <ul style="list-style-type: none"> Check the loading status (SW0069). Check the station number overlap status (SW0098). Check the loading/parameter consistency status (SW009C).
Does the consistency flag remain ON?	Set to OFF the consistency flag.	

Trouble description	Details to be checked	Confirmation method	
Outputs are disabled in a remote I/O station.	Is the remote I/O station executing data link?	Check the following: <ul style="list-style-type: none"> • Check the LED display on the corresponding remote I/O station. • Check the other station data link status of the master station (SW0080). 	
	Is the refresh command output (BFM#10 b0) ON in the master station?	Confirm the sequence program.	
	Is data written to the correct address of remote output RY (buffer memory)?	Confirm the sequence program.	
	Is the corresponding station set as a reserved station?	Check the following: <ul style="list-style-type: none"> • Check the parameters. • Check the reserved station specified status (SW0074). 	
	Does the station number overlap?	Check the following: <ul style="list-style-type: none"> • Check the station number setting. • Check the loading status (SW0069). • Check the station number overlap status (SW0098). 	
	Do the settings match?	Check the following: <ul style="list-style-type: none"> • Check the loading status (SW0069). • Check the station number overlap status (SW0098). • Check the loading/parameter consistency status (SW009C). 	
	Does the consistency flag remain ON?	Set to OFF the consistency flag	
Remote input (RX) in a remote device station cannot be received.	Is the remote device station executing data link?	Check the following: <ul style="list-style-type: none"> • Check the LED display on the corresponding remote device station. • Check the other station data link status of the master station (SW0080). 	
	Is data read from the correct address of remote input RX (buffer memory)?	Confirm the sequence program.	
	Is the corresponding station set as a reserved station?	Check the following: <ul style="list-style-type: none"> • Check the parameters. • Check the reserved station specified status (SW0074). 	
	Does the station number overlap?	Check the following: <ul style="list-style-type: none"> • Check the station number setting. • Check the loading status (SW0069). • Check the station number overlap status (SW0098). 	
	Do the settings match?	Check the following: <ul style="list-style-type: none"> • Check the loading status (SW0069). • Check the station number overlap status (SW0098). • Check the loading/parameter consistency status (SW009C). 	
		Does the consistency flag remain ON?	Set to OFF the consistency flag.
		Is the remote device station initialization procedure registration being executed?	Check if the remote device station initialization procedure registration instruction (SB000D) is ON.

11	Programming
12	Remote I/O Communication Example
13	Remote Device Communication Example
14	Int. Device Communication Example
15	Compound Sys. Communication Example
16	Troubleshooting
A	Version Information
B	Setting Sheet
C	Differences with FX2N-16CCL-M

Trouble description	Details to be checked	Confirmation method
Remote output (RY) in a remote device station cannot be set to ON or OFF.	Is the remote device station executing data link?	Check the following: • Check the LED display on the corresponding remote device station. • Check the other station data link status of the master station (SW0080).
	Is the refresh command output (BFM#10 b0) ON in the master station?	Confirm the sequence program.
	Is data written to the correct address of remote output RY (buffer memory)?	Confirm the sequence program.
	Is the corresponding station set as a reserved station?	Check the following: • Check the parameters. • Check the reserved station specified status (SW0074).
	Does the station number overlap?	Check the following: • Check the station number setting. • Check the loading status (SW0069). • Check the station number overlap status (SW0098).
	Do the settings match?	Check the following: • Check the loading status (SW0069). • Check the station number overlap status (SW0098). • Check the loading/parameter consistency status (SW009C).
	Does the consistency flag remain ON?	Set to OFF the consistency flag.
Data in remote register (RWr) in a remote device station cannot be received.	Is the remote device station executing data link?	Check the following: • Check the LED display on the corresponding remote device station. • Check the other station data link status of the master station (SW0080).
	Is data read from the correct address of remote register RWr (buffer memory)?	Confirm the sequence program.
	Is the corresponding station set as a reserved station?	Check the following: • Check the parameters. • Check the reserved station specified status (SW0074).
	Does the station number overlap?	Check the following: • Check the station number setting. • Check the loading status (SW0069). • Check the station number overlap status (SW0098).
	Do the settings match?	Check the following: • Check the loading status (SW0069). • Check the station number overlap status (SW0098). • Check the loading/parameter consistency status (SW009C).
	Does the consistency flag remain ON?	Set to OFF the consistency flag.
	Is the remote device station initialization procedure registration being executed?	Check if the remote device station initialization procedure registration instruction (SB000D) is ON.

Trouble description	Details to be checked	Confirmation method
Data cannot be written to remote register (RWw) in a remote device station.	Is the remote device station executing data link?	Check the following: • Check the LED display on the corresponding remote device station. • Check the other station data link status of the master station (SW0080).
	Is data written to the correct address of remote register RWw (buffer memory)?	Confirm the sequence program.
	Is the corresponding station set as a reserved station?	Check the following: • Check the parameters. • Check the reserved station specified status (SW0074).
	Does the station number overlap?	Check the following: • Check the station number setting. • Check the loading status (SW0069). • Check the station number overlap status (SW0098).
	Do the settings match?	Check the following: • Check the loading status (SW0069). • Check the station number overlap status (SW0098). • Check the loading/parameter consistency status (SW009C).
	Does the consistency flag remain ON?	Set to OFF the consistency flag.
	Is the remote device station initialization procedure registration being executed?	Check if the remote device station initialization procedure registration instruction (SB000D) is ON.
Remote input (RX) in an intelligent device station cannot be received.	Is the intelligent device station executing data link?	Check the following: • Check the LED display on the corresponding intelligent device station. • Check the other station data link status of the master station (SW0080).
	Is data read from the correct address of remote input RX (buffer memory)?	Confirm the sequence program.
	Is the corresponding station set as a reserved station?	Check the following: • Check the parameters. • Check the reserved station specified status (SW0074).
	Does the station number overlap?	Check the following: • Check the station number setting. • Check the loading status (SW0069). • Check the station number overlap status (SW0098).
	Do the settings match?	Check the following: • Check the loading status (SW0069). • Check the station number overlap status (SW0098). • Check the loading/parameter consistency status (SW009C).
	Does the consistency flag remain ON?	Set to OFF the consistency flag.

11

Programming

12

Remote I/O
Communication
Example

13

Remote Device
Communication
Example

14

Int. Device
Communication
Example

15

Compound Sys.
Communication
Example

16

Troubleshooting

A

Version
Information

B

Setting Sheet

C

Differences with
FX2N-16CCL-M

Trouble description	Details to be checked	Confirmation method
Remote output (RY) in an intelligent device station cannot be set to ON or OFF.	Is the intelligent device station executing data link?	Check the following: • Check the LED display on the corresponding intelligent device station. • Check the other station data link status of the master station (SW0080).
	Is the refresh command output (BFM#10 b0) ON in the master station?	Confirm the sequence program.
	Is data written to the correct address of remote output RY (buffer memory)?	Confirm the sequence program.
	Is the corresponding station set as a reserved station?	Check the following: • Check the parameters. • Check the reserved station specified status (SW0074).
	Does the station number overlap?	Check the following: • Check the station number setting. • Check the loading status (SW0069). • Check the station number overlap status (SW0098).
	Do the settings match?	Check the following: • Check the loading status (SW0069). • Check the station number overlap status (SW0098). • Check the loading/parameter consistency status (SW009C).
Data in remote register (RWr) in an intelligent device station cannot be received.	Is the intelligent device station executing data link?	Check the following: • Check the LED display on the corresponding intelligent device station. • Check the other station data link status of the master station (SW0080).
	Is data read from the correct address of remote register RWr (buffer memory)?	Confirm the sequence program.
	Is the corresponding station set as a reserved station?	Check the following: • Check the parameters. • Check the reserved station specified status (SW0074).
	Does the station number overlap?	Check the following: • Check the station number setting. • Check the loading status (SW0069). • Check the station number overlap status (SW0098).
	Do the settings match?	Check the following: • Check the loading status (SW0069). • Check the station number overlap status (SW0098). • Check the loading/parameter consistency status (SW009C).
	Does the consistency flag remain ON?	Set to OFF the consistency flag.

Trouble description	Details to be checked	Confirmation method
Data cannot be written to remote register (RWw) in an intelligent device station.	Is the intelligent device station executing data link?	Check the following: • Check the LED display on the corresponding intelligent device station. • Check the other station data link status of the master station (SW0080).
	Is data written to the correct address of remote register RWw (buffer memory)?	Confirm the sequence program.
	Is the corresponding station set as a reserved station?	Check the following: • Check the parameters. • Check the reserved station specified status (SW0074).
	Does the station number overlap?	Check the following: • Check the station number setting. • Check the loading status (SW0069). • Check the station number overlap status (SW0098).
	Do the settings match?	Check the following: • Check the loading status (SW0069). • Check the station number overlap status (SW0098). • Check the loading/parameter consistency status (SW009C).
Data link cannot be stopped.	Does the consistency flag remain ON?	Set to OFF the consistency flag.
	Is the data link stop (SB0002) ON? Has an error occurred?	Confirm the sequence program. Check the data link stop result (SW0045).
Data link cannot be restarted.	Is the data link restart (SB0000) ON? Has an error occurred?	Confirm the sequence program. Check the data link restart result (SW0041).
	Is the corresponding station disconnected?	Check the cable connection visually or with a line test.
A remote stations/intelligent device stations cannot start up.	Are the settings consistent between the station information (parameter) and the remote station?	Confirm the contents of the parameters.
	Does the station number overlap with another unit?	Check the station number setting switch.
Faulty stations cannot be detected.	Are stations specified as error invalid ones? Does the station number overlap?	Confirm the contents of the parameters. Check the station number.
	Can faulty stations be detected by the communication status in other stations (SW0080)? Is normal communication established when the transmission speed is slowed (to 156 k bps, for example)?	• Check the switch settings in the faulty station. • Check whether the cable wiring is correct. • Check whether the cable shield is grounded. • Connect the terminal resistor that matches the cable type used to the terminal stations located at each end of the CC-Link system.
The remote device station is not operating normally.	Are there any errors in the initialization procedure registration of the remote device station?	Check the following: • Check the sequence program. • Check the network parameters.
GX Works2 cannot communicate with the other station PLC.	Does the programmable controller CPU of the station set in "Transfer setup" have an error? Is the station set in "Transfer setup" executing data link?	Check the error code of the PLC. Check whether the "L RUN" LED of the corresponding station is on or not.
	Initialization procedure registration of the corresponding station stops and is not completed. (The execution procedure number in the remote device station initialization procedure registration execution individual information (SW0110 to SW0117) has stopped.)	Is the station participating in the data link?
Is the station set as a reserved station?		Confirm the reserved station specification status (SW0074). Correct the network parameters, and retry the operation after establishing the data link.
Is the parameter setting for remote device station initialization procedure registration correct?		Confirm the network parameters. Correct the network parameters, reset the remote device station and retry the operation.

11	Programming
12	Remote I/O Communication Example
13	Remote Device Communication Example
14	Int. Device Communication Example
15	Compound Sys. Communication Example
16	Troubleshooting
A	Version Information
B	Setting Sheet
C	Differences with FX2N-16CCL-M

Trouble description	Details to be checked	Confirmation method
The master station crashed and the data link stopped after remote device station initialization procedure registration was instructed.	Does the ready signal (RX1B) of the remote device station remain OFF after the data link is established?	Monitor the remote input (RX) of the remote device station. Reset the remote device station and retry the operation.
Initialization processing ended in error.	Check the error code.	Check the remote device station initialization procedure instruction result (SW005F). Check the error code list and remedy the problem.

16.2 Troubleshooting when ERR. LED is Flashing in Master Station

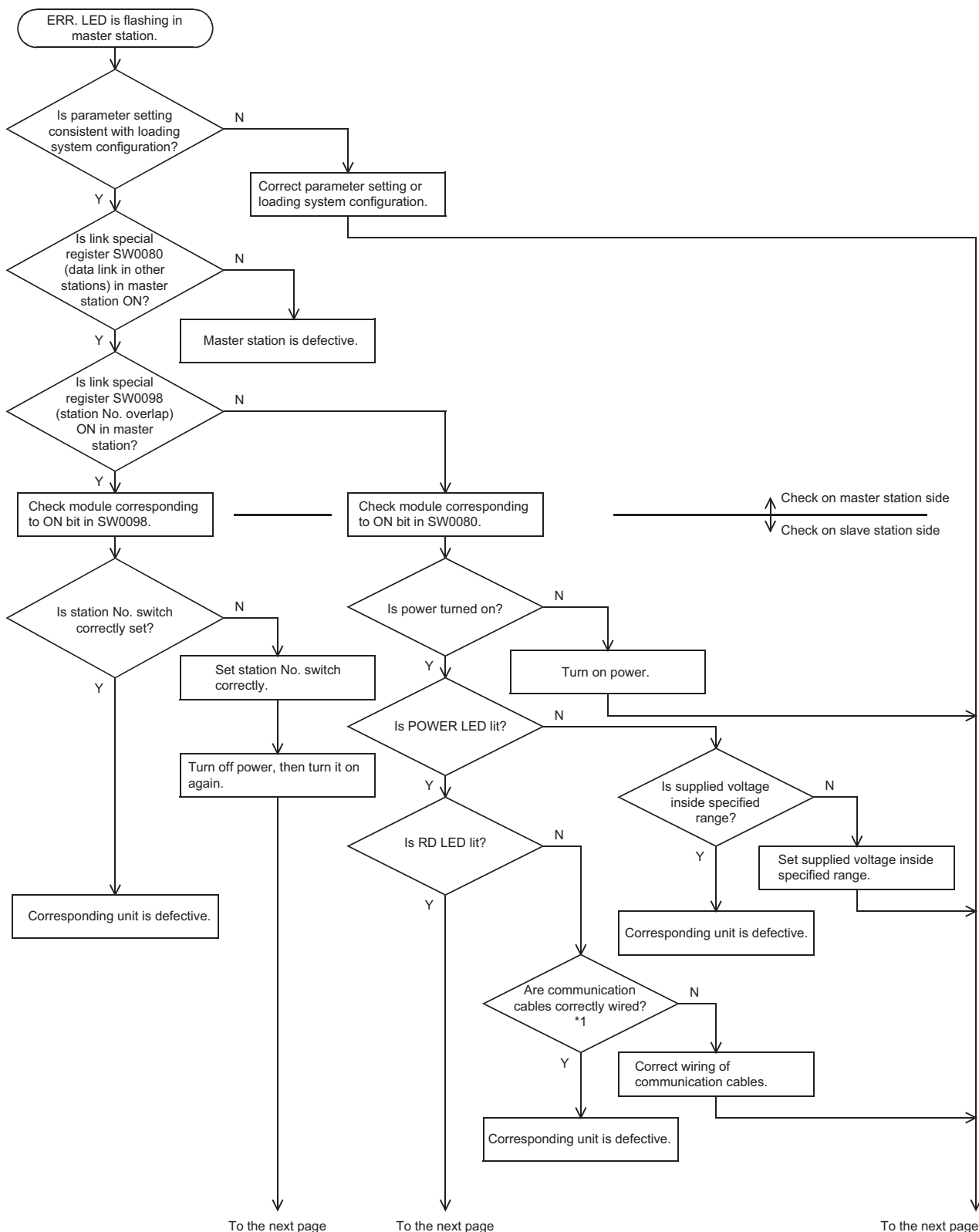

*1. Check the terminal resistors, the FG connection, the total extension distance and the station-to-station distance.

11	Programming
12	Remote I/O Communication Example
13	Remote Device Communication Example
14	Int. Device Communication Example
15	Compound Sys. Communication Example
16	Troubleshooting
A	Version Information
B	Setting Sheet
C	Differences with FX2N-16CCL-M

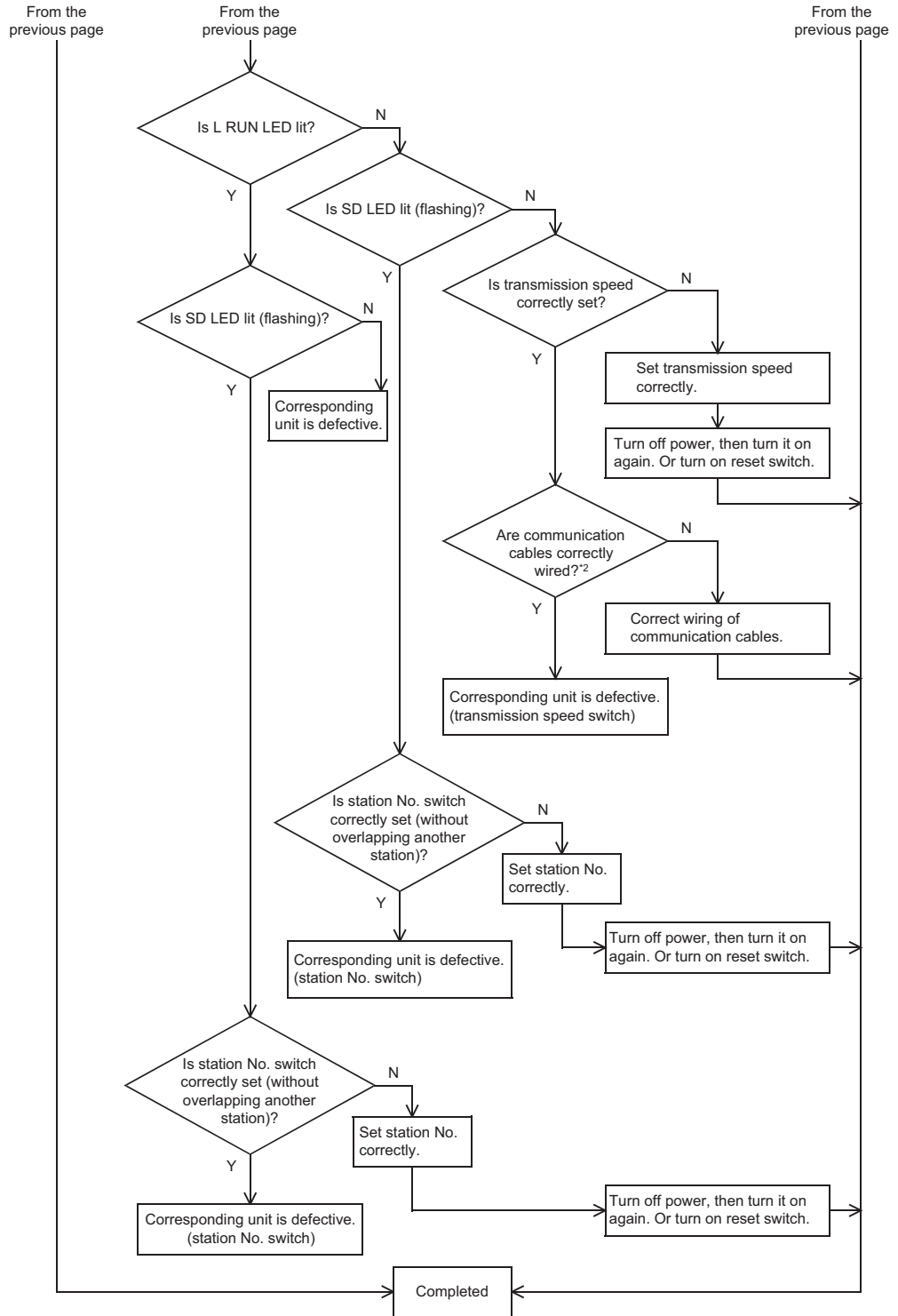

*2. Check the terminal resistors, the FG connection, the total extension distance and the station-to-station distance.

16.3 Troubleshooting by Error Code

1. Error codes detected by the FX3U-16CCL-M

BFM#29 stores the error code detected by the FX3U-16CCL-M.

→ For details error code, refer to Subsection 10.5.1.

2. The error code on the CC-Link network

The error code stored in the link special register (SW) is shown below.

Error code (Hex.)	Error definition	The cause of the error occurrence (details)	Error corrective action
B110	Transient data can not be received.	A line error has occurred.	Check the line.
B111	Transient data receiving order error	A line error has occurred.	Check the line.
B112	Transient data length error	A line error has occurred.	Check the line.
B113	Transient data ID error	A line error has occurred.	Check the line.
B115	Link error	A line error has occurred.	Check the line.
B120	Forced termination of the remote device station initialize procedure registration function	In the remote device station initialize procedure registration function, the specification of the remote device station initialize procedure registration (SB000D) was turned OFF before all procedures were completed.	Do not turn the specification of the remote device station initialize procedure registration (SB000D) off until all procedures are completed.
B125	Parameter not set error of the remote device station initialize procedure registration function	The specification of the remote device station initialize procedure registration function (SB000D) was turned on without setting the remote device station initialize procedure registration.	Turn on the specification of the remote device station initialize procedure registration function (SB000D) after setting the remote device station initialize procedure registration.
B201	Corresponding station error during sending	A data link error occurred at the corresponding station during transient transmission.	Check the communication status of other stations, whether or not a temporary error invalid station is specified, or if the corresponding station is stopped.
B205	Transient target station error	A transient request was issued to other than the intelligent device station.	Check the target station.
B301	Request for processing during link stop	The request for line test was given while link was stopped.	Execute the line test while link is executed.
B302	Specified station number setting error	When the request for temporary error invalid station or the request for cancel of temporary error invalid station was given, the specified station number was beyond the maximum communication station number.	Specify a station number not more than the maximum communication station number.
B303	Specified station number no-setting error	When the request for temporary error invalid station or the request for cancel of temporary error invalid station was given, the station number was not specified.	Specify a station number. (SW0003, SW0004)
B304	Line test error station detected	An error was detected in a remote station and intelligent device station when a line test was performed.	Check that the remote station and intelligent device station is operational and that the cable is not disconnected.
B305	Line test error station detected (Response data error)	An error was detected in response data error when a line test was performed.	Change the remote device stations/intelligent device stations.
B306	Specified station setting error	When the request for temporary error invalid station or the request for cancel of temporary error invalid station was given, a head station was not specified.	Specify a head station in giving the request for temporary error invalid station or the request for cancel of temporary error invalid station.
B307	Data link error in all stations	When the following request was given, there was data link error in all stations. • Data link restart (SB0000) • Data link stop (SB0002)	Wait until the data link becomes normal, then give the request again.

11

Programming

12

Remote I/O
Communication
Example

13

Remote Device
Communication
Example

14

Int. Device
Communication
Example

15

Compound Sys.
Communication
Example

16

Troubleshooting

A

Version
Information

B

Setting Sheet

C

Differences with
FX2N-16CCL-M

Error code (Hex.)	Error definition	The cause of the error occurrence (details)	Error corrective action
B308	Station number setting error (loading status)	The station number of a slave station is not set inside the range from 1 to 16.	Set a slave station number inside the specification range (1 to 16).
B309	Station number overlap error	In connected units, a station number overlaps (including the number of occupied stations, excluding overlap of a head station number).	Check the station numbers of the units. (Including the number of occupied stations.)
B30A	Loading/ parameter consistency error	The station type is different between the unit and the parameter.	Set the parameter correctly.
B30B	Loading/ parameter consistency error	The loading status is not consistent with the network parameters.	Align the loading status with the network parameters.
B30D	Initial status	Data link restart (SB0000) or data link stop (SB0002) was issued being initial processing.	Issue the request after the data link is started.
B310	Data link restart error	Data link restart (SB0000) was executed for the station that was performing a data link.	Execute Data link restart (SB0000) for the station that has stopped a data link with Data link stop (SB0002).
B311	Data link stop error	Data link stop (SB0002) was executed for the station that had stopped a data link.	Execute Data link stop (SB0002) for the station that is performing a data link.
B31B	Transmission speed test execution error	The transmission speed test (SB0002) was executed during data link.	Set Data link stop (SB0002) to ON and then Transmission speed test request (SB000B) to ON.
B384	Station number setting error (parameter)	The station number in the station information is not set inside the range from 1 to 16.	Set within the range of "1 to 16".
B385	Total number of modules setting error (parameter)	The total number of occupied stations in the station information is beyond 16.	Set the total number of occupied stations to "16 stations or less".
B386	Number of occupied stations setting error (parameter)	The number of occupied stations in the station information is set to 0 for every station.	Set the occupied station number to a value between "1 and 4".
B388	Station type setting error (parameter)	The station type in the station information is not set inside the setting range.	For remote net ver. 1 mode, confirm that slave station types are also set up for ver. 1.
B38A	Station information specification (Number of remote I/O stations > 8 stations)	The number of remote I/O stations was set to "9 stations or more" in the station information parameter.	Set the remote I/O station to "8 stations or less" in the station information parameter.
B38B	Remote device station setting error (parameter)	The total number of points (RX/RV) of remote device stations and intelligent device stations exceeds 256 points or the total number of remote device stations and intelligent device stations was set to "9 stations or more".	Set the total number of remote device station and intelligent device stations to "8 stations or less" in the station information parameter.
B391	Number of retries setting error (parameter)	The number of retries (parameter) is not set inside the range from 1 to 7.	Set a value inside the specification range (1 to 7).
B392	Operation against CPU down specification error (parameter)	The operation specification against CPU down (parameter) is not set to 0 or 1.	Set 0 or 1.
B394	Number of automatic return units setting error (parameter)	The number of automatic return units (parameter) is not set inside the range from 1 to 10.	Set a value inside the specification range (1 to 10).
B396	Station number overlap error (parameter)	In the station information (parameter), one station number is specified twice or more.	Use each station number only once.
B397	Station information setting error	Station information of parameter setting is out of order.	Set station information in the order of the station number.
B398	Number of occupied stations setting error (parameter)	In the station information (parameter), the number of occupied stations is not set inside the range from 1 to 4.	Set a value inside the specification range (1 to 4).
B399	Number of connected units setting error (parameter)	The number of connected units (parameter) is not set inside the range from 1 to 16.	Set a value inside the specification range (1 to 16).
B39B	Reserved station specification error (parameter)	In the reserved station specification (parameter), all stations are set as reserved ones.	Confirm the reserved station specification.

Error code (Hex.)	Error definition	The cause of the error occurrence (details)	Error corrective action
B39F	Remote net additional mode station number invalid	In the remote net additional mode, the "maximum station number of ver. 1 compatible slave stations" is greater than the "minimum station number of ver. 2 compatible slave stations" in the network parameter setting.	In the remote net additional mode, make network parameter setting so that the "maximum station number of ver. 1 compatible slave stations" is less than the "minimum station number of ver. 2 compatible slave stations".
B3A5	Mode invalid (parameter)	The station type in the mode (parameter) is not set inside the range from 0 to 2.	Set the mode inside the range from 0 to 2.
B601	Request type error	An unsupported request type was set.	Set the request type correctly.
B771	Transient request overload error	There are too many transient requests to the corresponding station.	Wait a while and then retransmit (transient overloaded status).
B774	Transient request error	The target station was not an intelligent device station.	Check if the target station is an intelligent device station.
B778	Response time out	A response was not received from the requested station.	Check the requested unit and cables.
B782	Station number specification error	The transmission destination and source stations were the same when other station connection was specified.	Check the transmission destination station number, or change to master connection.
BA02	Network parameter error	A network parameter is abnormal.	Set a valid network parameter.
BA19	Error in corresponding station	In the line test, communication was disabled in the tested station.	Check the corresponding station and cables.
BA1B	Error in all stations	In the line test 1, communication was disabled in all stations.	Check the cables.
BBC1	Transmission rate setting switch error	A transmission rate setting switch is not set within the appropriate range.	Review the Transmission rate setting switch.
BBC2	Station number setting error	The station number switch setting of the unit is set to a value other than "0 to 16".	Check the station number.
BBC5	Master station overlap error	Multiple master stations exist on the same line.	Reduce the number of master stations on the same line to one. Also, check the line status.
4B03	Corresponding related error	<ul style="list-style-type: none"> The specified route is not supported by the specified main unit version. The communication target main unit is not mounted. 	Check whether the specified route is supported.

11

Programming

12

Remote I/O
Communication
Example

13

Remote Device
Communication
Example

14

Int. Device
Communication
Example

15

Compound Sys.
Communication
Example

16

Troubleshooting

A

Version
Information

B

Setting Sheet

C

Differences with
FX2N-16CCL-M

16.4 CC-Link Diagnostics

After connecting all units with cables dedicated to CC-Link, check the status of each unit using GX Works2 to confirm that data link is enabled.

Refer to Section 3.2 for applicable PLCs and GX Works2 versions supporting network parameters. Refer to the GX Works2 Version 1 Operating Manual (Common) for details of CC-Link diagnostics.

16.4.1 Host monitoring/Other station monitoring

Monitor, for example, the data link status of the host station (connected to GX Works2) and other stations (not connected to GX Works2).

Select the [Diagnostics] → [CC-Link Diagnostics] on GX Works2.

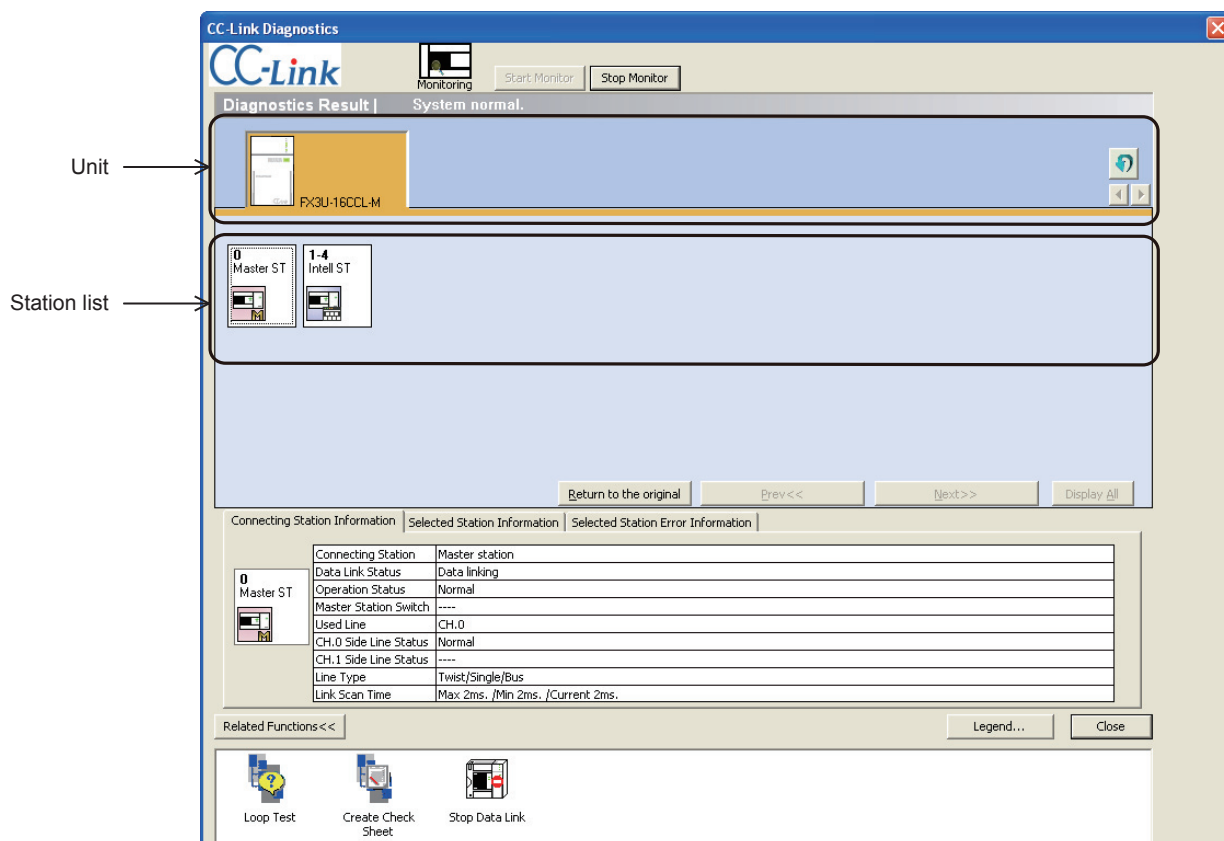

Item	Description
Diagnostics Result	Displays the number of errors/warnings occurring in all connected units.
Unit	Displays the information of the FX3U-16CCL-M.
Station list	Displays the list of stations that configure the CC-Link system.
Connecting Station Information	Displays the data linking status, etc. of the connected station (host).
Selected Station Information	Displays the number of the station, etc. of the (other) station selected in the station list.
Selected Station Error Information	Displays the error information of the station selected in the station list.
Related Functions	Switches to display or hide the related function icons. Refer to the following for details of the related functions. <ul style="list-style-type: none"> • Loop Test (Refer to Subsection 16.4.2) • Create Check Sheet (Refer to Subsection 16.4.3) • Start Data Link/Stop Data Link (Refer to Subsection 16.4.4)
Legend	Displays the explanation of the icons on the diagnostics screen.

16.4.2 Loop test/Obtain transmission speed setting

1. Loop test

Checks the line operation of all stations or for the specified station.

- Operation procedure
 - 1) Connect all the units with CC-Link dedicated cables.
 - 2) In GX Works2, select [Diagnostics] and then [CC-Link Diagnostics] and double-click the "Loop Test" icon.

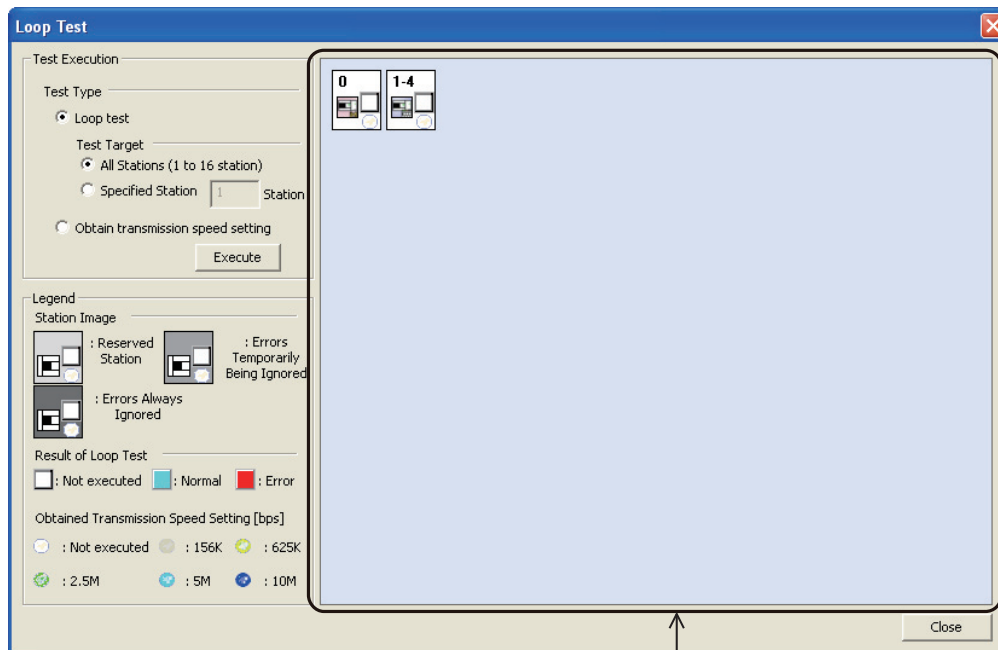

Test result

- 3) Set the test type to "Loop test".
Perform the loop test by selecting "All stations" or specifying a station number.
All stations : Select this when performing the test on all of the connected stations.
Specified station : Select this when performing the test on the specified station.
Specify the smallest number of the occupied stations.
(Example) When a four-occupied station and a two-occupied station are connected

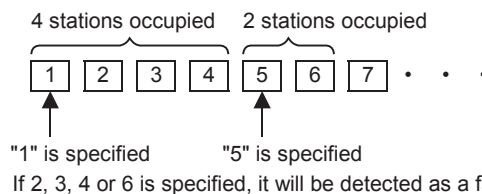

- 4) Click the "Execute" button.
A loop test is performed, and the result is displayed in "Test result".

Caution

- Do not write to buffer memory addresses "5E0H" and "608H".
- Do not concurrently perform loop tests by programs and other peripherals. If this happens, the loop test may not operate normally.

2. Obtain transmission speed setting

Checks the transmission speed settings of all stations.

- Operation procedure
 - 1) Connect all the units with CC-Link dedicated cables.
 - 2) Set to "STOP" the RUN/STOP switch in the PLC.
 - 3) In GX Works2, select [Diagnostics] and then [CC-Link Diagnostics] and double-click the "Loop Test" icon.

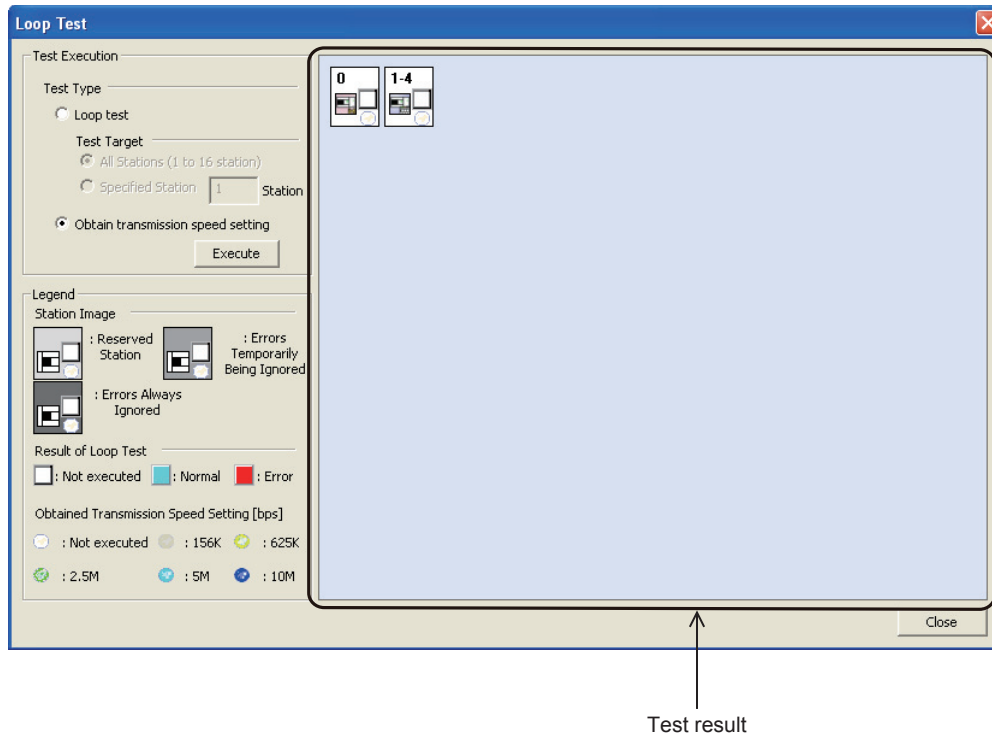

- 4) Select "Obtain transmission speed setting" for Test Type.
- 5) Click the "Execute" button.
The transmission speed settings are obtained, and the results are displayed in "Test result".

Caution

- Do not write to buffer memory addresses 5E0H, 5E4H, 5F8H, 641H, 645H, 783H and 784H.
- Do not concurrently obtain transmission speed settings by programs and other peripherals. If this happens, the "Obtain transmission speed setting" may not be operated normally.
Do not perform the "Obtain transmission speed setting" at the same time with the check sheet creation wizard.

16.4.3 Creating a check sheet

By following the wizard, check sheets can be created for troubleshooting with the open field network CC-Link troubleshooting guidance.

1. Operation procedure

- 1) In GX Works2, select [Diagnostics] and then [CC-Link Diagnostics] and double-click the "Create Check Sheet" icon.

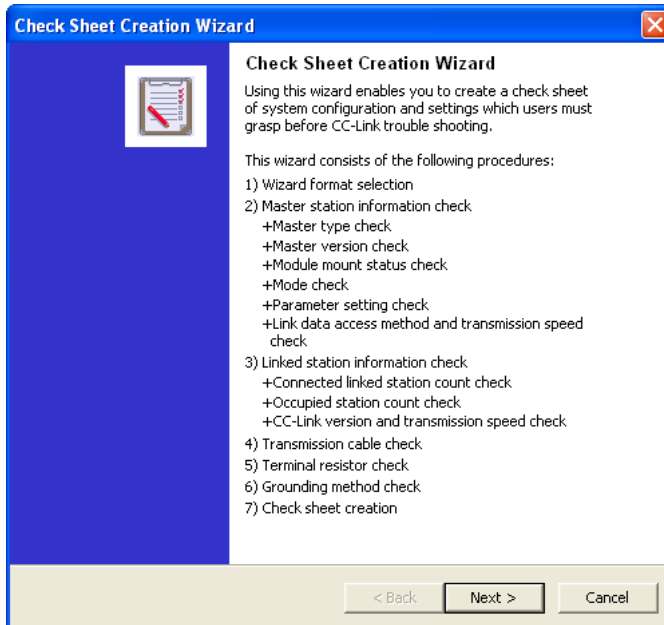

- 2) Set according to the screen contents.
The created check sheet is saved in Excel format.
- 3) Perform troubleshooting by using the open field network CC-Link troubleshooting guidance.

Point

- Precautions when checking transmission speed
Do not concurrently obtain transmission speed settings by programs and other peripherals. If this happens, the "Obtain transmission speed setting" may not be operated normally.
- Check sheet
When Microsoft® Excel 2000 or later is installed, the system configuration diagram is output.

11

Programming

12

Remote I/O
Communication
Example

13

Remote Device
Communication
Example

14

Int. Device
Communication
Example

15

Compound Sys.
Communication
Example

16

Troubleshooting

A

Version
Information

B

Setting Sheet



C

Differences with
FX2N-16CCL-M

2. Example of a check sheet

The following is an example of the check sheet when Microsoft® Excel 2000 or later is installed.

Confirmation Item	Contents	
1. Master Station	[1]Master Type	Programmable Controller PLC Master Module
		FX3U/FX3UC FX3U-16CCL-M
	[2]Master Version	Programmable Controller PLC Master Module
		3.10 1.00
	[3]Module Mount Status	I/O Address:
		0
	[4]Other Network Module	Other Network Module:

	[5]Mode	Mode Setting: Scan Mode: Module Mode:
		[*]Remote Net Mode([]Ver.1/[]Additional/[*]Ver.2) / []Remote I/O Net Mode --- ---
[6]Parameter	Checking the parameter matching status between the specification and PLC	
	Parameter	Setting
	Number of PLCs	1Count
	Standby Master Station Setting	---
	PLC Down Drive Specification	[*]Stop/[]Continue
	Reserved Station	None
	Error Invalid Station	None
	Station Information	Written in the system configuration
	[7]Parameter Setting	[*]GX WORKS2/[]Dedicated Instruction/[]FROM/TO Instruction
	[8]Link Start Method	[]Startup by Buffer Memory:Y6 / []Startup by E2PROM:Y8 (Only QnA, A, FX Series)
[9]Link Data Access	[]Auto Refresh/[]Dedicated Instruction/[*]FROM/TO Instruction	
[10]Transmission Speed	[*]10M/[]5M / []2.5M / []625k / []156kbps	
2. Linked Station	[11]Connected Count	1Count
	*:The details have been described	Remote I/O Station:0Count, Remote Device Station:0Count, Intelligent Device Station:1Count
	[12]Station Type*	[*]Number of occupied stations of each station(Please check it when you confirm it.)
	[13]Number of Occupied Stations*	[*]Ver.1 / []Ver2(Expanded Cyclic Setting:[]1Times, []2Times, []4Times, []8Times)
	[14]CC-Link Version*	[]10M/[]5M / []2.5M / []625k / []156kbps
3. Transmission Cable	[16]Cable Type	Cable Model Name:
	[17]Transmission Distance	Total Extension Distance:
		m
[18]Inter-Station Distance	Distance between Shortest Station:	
	m	
4. Terminal Resistor	[19]Resistance Value	[*]110ohm / []130ohm / []Not Exist
	[20]Connected Terminal	[]Connection between DA-DB of terminal resistor(Please check it when you confirm it.)
5. Grounding	[21]FG Terminal	[]Grounding of FG terminal of each station(Please check it when you confirm it.)
		Describe the installation status to "6.System Configuration" when it is not set up in each station.
6. System Configuration	Station No., Station Type	 
	Number of Occupied Stations	
	Length of Cable	

16.4.4 Starting/stopping data link

Start/stop the data link.

- Operation procedure
 - Stop the data link
Double-click "Diagnostics" → "CC-Link Diagnostics" → "Stop Data Link" in GX Works2.
 - Start the data link
Double-click "Diagnostics" → "CC-Link Diagnostics" → "Start Data Link" in GX Works2.

Caution

Do not execute at one time by programs and other peripherals. If executing at one time, data link stop/restart may not operate normally.

16.4.5 Setting/canceling temporary error invalid station

Set or cancel temporary error invalid stations.

- Operation procedure
 - Set the [Diagnostics] → [CC-Link Diagnostics] using GX Works2.
- 1) Select a station to be set as a temporary error invalid station in the station list.
- 2) Execute with right click → Shortcut menu → [Set/Cancel Temporary Error Invalid Station].

Caution

Do not execute at one time by programs and other peripherals. If executed at one time, temporary error invalid station setting may not operate normally.

11

Programming

12

Remote I/O
Communication
Example

13

Remote Device
Communication
Example

14

Int. Device
Communication
Example

15

Compound Sys.
Communication
Example

16

Troubleshooting

A

Version
Information

B

Setting Sheet

C

Differences with
FX2N-16CCL-M

MEMO

Appendix A: Version Information

Appendix A-1 Version Information

Appendix A-1-1 Version check method

The FX3U-16CCL-M version is shown as "VERSION" on the label attached to the right side of the module as seen from the front.

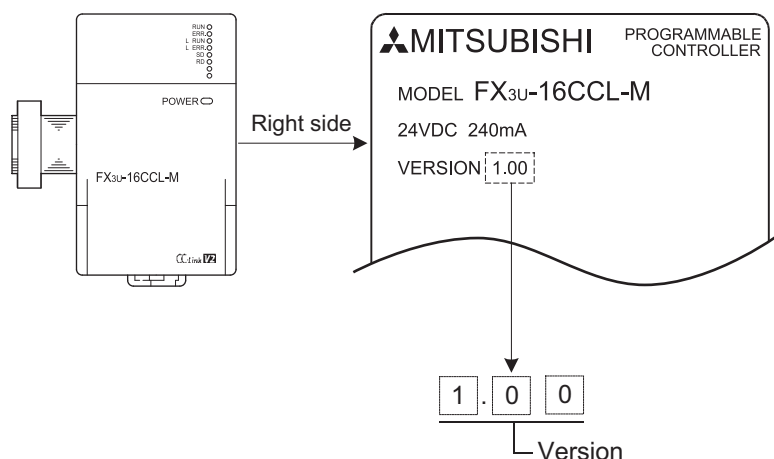

Appendix A-1-2 Version upgrade history

The table below shows the version upgrade history for the FX3U-16CCL-M.

Version	Contents of version upgrade
Ver. 1.00	First product

11
Programming

12
Remote I/O
Communication
Example

13
Remote Device
Communication
Example

14
Int. Device
Communication
Example

15
Compound Sys.
Communication
Example

16
Troubleshooting

A
Version
Information

B
Setting Sheet

C
Differences with
FX2N-16CCL-M

Appendix B: Setting Sheet

Appendix B-1 Parameter setting sheet

Item	Setting range	BFM No.		Default	Setting value	Remarks
		Hex.	Dec.			
Mode	0: Remote net ver. 1 mode 1: Remote net additional mode 2: Remote net ver. 2 mode	#0H	#0	K0		-
Number of connected units	For FX3U/FX3UC PLC 1 to 16 (units) For FX3G/FX3GC PLC 1 to 12 (units)	#1H	#1	K8		-
Number of retries	1 to 7 (times)	#2H	#2	K3		-
Number of automatic return units	1 to 10 (units)	#3H	#3	K1		-
Operation specification when CPU is down	0: Stop 1: Continue	#6H	#6	K0		-
Data link disorder station setting	0: Hold 1: Clear	#0CH	#12	K1		-
Case of CPU STOP setting	0: Refresh 1: Clears compulsorily	#0DH	#13	K0		-
Reserved station specification	Set to ON the bits corresponding to the station numbers to be set as reserved.	#10H	#16	K0		Station Nos. 1 to 16
Error invalid station specification	Set to ON the bits corresponding to the station numbers to be set as error invalid stations.	#14H	#20	K0		Station Nos. 1 to 16
Station information	b15 to b12 (Station type) 0H: Ver. 1 compatible remote I/O station 1H: Ver. 1 compatible remote device station 2H: Ver. 1 compatible intelligent device station 5H: Ver. 2 compatible single remote device station 6H: Ver. 2 compatible single intelligent device station 8H: Ver. 2 compatible double remote device station 9H: Ver. 2 compatible double intelligent device station BH: Ver. 2 compatible quadruple remote device station CH: Ver. 2 compatible quadruple intelligent device station EH: Ver. 2 compatible octuple remote device station FH: Ver. 2 compatible octuple intelligent device station b11 to b8 (Number of occupied stations) 1H: Occupies 1 station 2H: Occupies 2 stations 3H: Occupies 3 stations 4H: Occupies 4 stations b7 to b0 (Station No.) 01H to 10H (1 to 16)	#20H	#32	0101H		1st unit
		#21H	#33	0102H		2nd unit
		#22H	#34	0103H		3rd unit
		#23H	#35	0104H		4th unit
		#24H	#36	0105H		5th unit
		#25H	#37	0106H		6th unit
		#26H	#38	0107H		7th unit
		#27H	#39	0108H		8th unit
		#28H	#40	0000H		9th unit
		#29H	#41	0000H		10th unit
		#2AH	#42	0000H		11th unit
		#2BH	#43	0000H		12th unit
		#2CH	#44	0000H		13th unit
		#2DH	#45	0000H		14th unit
		#2EH	#46	0000H		15th unit
		#2FH	#47	0000H		16th unit

Appendix B-2 Station information setting sheet

Station number	Station type	Expanded cyclic setting	Number of occupied stations	Reserved station/invalid station specification
1				
2				
3				
4				
5				
6				
7				
8				
9				
10				
11				
12				
13				
14				
15				
16				

11
Programming

12
Remote I/O
Communication
Example

13
Remote Device
Communication
Example

14
Int. Device
Communication
Example

15
Compound Sys.
Communication
Example

16
Troubleshooting

A
Version
Information

B
Setting Sheet

C
Differences with
FX2N-16CCL-M

MEMO

Appendix C: Differences with FX2N-16CCL-M

This appendix describes the major differences between the FX3U-16CCL-M and the FX2N-16CCL-M.

Appendix C-1 Differences with FX2N-16CCL-M

The difference between FX3U-16CCL-M and FX2N-16CCL-M is shown in the following table.

	FX3U-16CCL-M	FX2N-16CCL-M
CC-Link applicable version	Ver. 2.00 (Ver. 1.10 also supported.)	Ver. 1.00
Connectable station classification	<ul style="list-style-type: none"> Remote I/O station Remote device station Intelligent device station 	<ul style="list-style-type: none"> Remote I/O station Remote device station
Maximum number of connectable stations	<ul style="list-style-type: none"> Remote I/O station: 8 maximum (FX3G/FX3GC PLC: 4 maximum) Remote device station + Intelligent device station: 8 maximum 	<ul style="list-style-type: none"> Remote I/O station: 7 maximum Remote device station: 8 maximum
Unit reset function from sequence program	Not provided	Provided
Parameter setting with sequence program	Provided	Provided
Parameter setting with GX Works2	Provided	Not provided
Parameter registration to EEPROM	Not provided	Provided
CC-Link diagnostics with GX Works2	Provided	Not provided
Transmission speed test	Provided	Not provided
Parameter verification test	Not provided	Provided
Expanded cyclic setting	Provided	Not provided
Slave station refresh/compulsory clear setting in case of programmable controller CPU STOP	Provided	Not provided
Consistency control function	Provided	Not provided
Remote device station initialization procedure registration function	Provided	Not provided
Accessing the other station from CC-Link	Provided	Not provided
Connectable PLC	FX3G/FX3GC/FX3U/FX3UC PLC	FX1N/FX1NC/FX2N/FX2NC/FX3G/FX3GC/FX3U/FX3UC PLC
Number of connectable units to the main unit	Only one FX3U-16CCL-M unit can be connected in a main unit. (An FX3U-16CCL-M cannot be attached to main unit with an FX2N-16CCL-M and/or FX2N-32ASI-M.)	The number of connectable units is based on the main unit. (The maximum units number which can be connected.)

11

Programming

12

Remote I/O
Communication
Example

13

Remote Device
Communication
Example

14

Int. Device
Communication
Example

15

Compound Sys.
Communication
Example

16

Troubleshooting

A

Version
Information

B

Setting Sheet

C

Differences with
FX2N-16CCL-M

MEMO

Warranty

Please confirm the following product warranty details before using this product.

1. Gratis Warranty Term and Gratis Warranty Range

If any faults or defects (hereinafter "Failure") found to be the responsibility of Mitsubishi occurs during use of the product within the gratis warranty term, the product shall be repaired at no cost via the sales representative or Mitsubishi Service Company. However, if repairs are required onsite at domestic or overseas location, expenses to send an engineer will be solely at the customer's discretion. Mitsubishi shall not be held responsible for any re-commissioning, maintenance, or testing on-site that involves replacement of the failed module.

[Gratis Warranty Term]

The gratis warranty term of the product shall be for one year after the date of purchase or delivery to a designated place. Note that after manufacture and shipment from Mitsubishi, the maximum distribution period shall be six (6) months, and the longest gratis warranty term after manufacturing shall be eighteen (18) months. The gratis warranty term of repair parts shall not exceed the gratis warranty term before repairs.

[Gratis Warranty Range]

- 1) The range shall be limited to normal use within the usage state, usage methods and usage environment, etc., which follow the conditions and precautions, etc., given in the instruction manual, user's manual and caution labels on the product.
- 2) Even within the gratis warranty term, repairs shall be charged for in the following cases.
 - a) Failure occurring from inappropriate storage or handling, carelessness or negligence by the user. Failure caused by the user's hardware or software design.
 - b) Failure caused by unapproved modifications, etc., to the product by the user.
 - c) When the Mitsubishi product is assembled into a user's device, Failure that could have been avoided if functions or structures, judged as necessary in the legal safety measures the user's device is subject to or as necessary by industry standards, had been provided.
 - d) Failure that could have been avoided if consumable parts (battery, backlight, fuse, etc.) designated in the instruction manual had been correctly serviced or replaced.
 - e) Relay failure or output contact failure caused by usage beyond the specified Life of contact (cycles).
 - f) Failure caused by external irresistible forces such as fires or abnormal voltages, and failure caused by force majeure such as earthquakes, lightning, wind and water damage.
 - g) Failure caused by reasons unpredictable by scientific technology standards at time of shipment from Mitsubishi.
 - h) Any other failure found not to be the responsibility of Mitsubishi or that admitted not to be so by the user.

2. Onerous repair term after discontinuation of production

- 1) Mitsubishi shall accept onerous product repairs for seven (7) years after production of the product is discontinued.
Discontinuation of production shall be notified with Mitsubishi Technical Bulletins, etc.
- 2) Product supply (including repair parts) is not available after production is discontinued.

3. Overseas service

Overseas, repairs shall be accepted by Mitsubishi's local overseas FA Center. Note that the repair conditions at each FA Center may differ.

4. Exclusion of loss in opportunity and secondary loss from warranty liability

Regardless of the gratis warranty term, Mitsubishi shall not be liable for compensation of damages caused by any cause found not to be the responsibility of Mitsubishi, loss in opportunity, lost profits incurred to the user or third person by Failures of Mitsubishi products, special damages and secondary damages whether foreseeable or not, compensation for accidents, and compensation for damages to products other than Mitsubishi products, replacement by the user, maintenance of on-site equipment, start-up test run and other tasks.

5. Changes in product specifications

The specifications given in the catalogs, manuals or technical documents are subject to change without prior notice.

6. Product application

- 1) In using the Mitsubishi MELSEC programmable logic controller, the usage conditions shall be that the application will not lead to a major accident even if any problem or fault should occur in the programmable logic controller device, and that backup and fail-safe functions are systematically provided outside of the device for any problem or fault.

- 2) The Mitsubishi programmable logic controller has been designed and manufactured for applications in general industries, etc. Thus, applications in which the public could be affected such as in nuclear power plants and other power plants operated by respective power companies, and applications in which a special quality assurance system is required, such as for Railway companies or Public service purposes shall be excluded from the programmable logic controller applications.

In addition, applications in which human life or property that could be greatly affected, such as in aircraft, medical applications, incineration and fuel devices, manned transportation, equipment for recreation and amusement, and safety devices, shall also be excluded from the programmable logic controller range of applications.

However, in certain cases, some applications may be possible, providing the user consults their local Mitsubishi representative outlining the special requirements of the project, and providing that all parties concerned agree to the special circumstances, solely at the users discretion.

Revised History

Date	Revision	Description
8/2011	A	First Edition
11/2011	B	<ul style="list-style-type: none"> • Content for network parameters are added. (Subsection 1.1.2, Section 3.2, Subsection 6.2.5, Chapter 8, etc.) • Content for the other station access function from CC-Link are added. (Subsection 1.1.2, Section 3.2, Subsection 6.4.8, etc.) • Content for the remote device station initialization procedure registration function are added. (Subsection 1.1.2, Section 3.2, Subsection 6.4.1, Section 10.12, etc.) • Content for the CC-Link diagnostic function are added. (Subsection 1.1.2, Section 3.2, Section 16.4, etc.) • Content for FX3U/FX3UC PLC Ver. 3.10 are added. (Section 3.2) • Clerical error correction.
5/2012	C	<ul style="list-style-type: none"> • Content for FX3G/FX3GC PLC Ver. 2.00 are added. (Section 3.2) • FX3GC Series PLC is added. • Clerical error correction.

FX3U-16CCL-M

USER'S MANUAL

 **mitsubishi electric corporation**

HEAD OFFICE: TOKYO BUILDING, 2-7-3 MARUNOUCHI, CHIYODA-KU, TOKYO 100-8310, JAPAN
HIMEJI WORKS: 840, CHIYODA CHO, HIMEJI, JAPAN

MODEL	FX3U16CCL-M-U-E
MODEL CODE	09R724