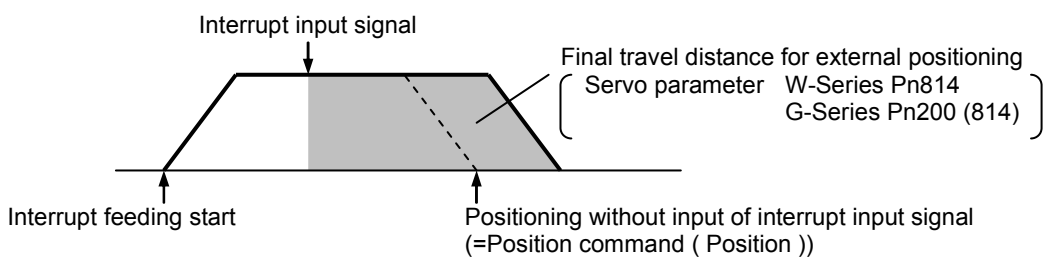
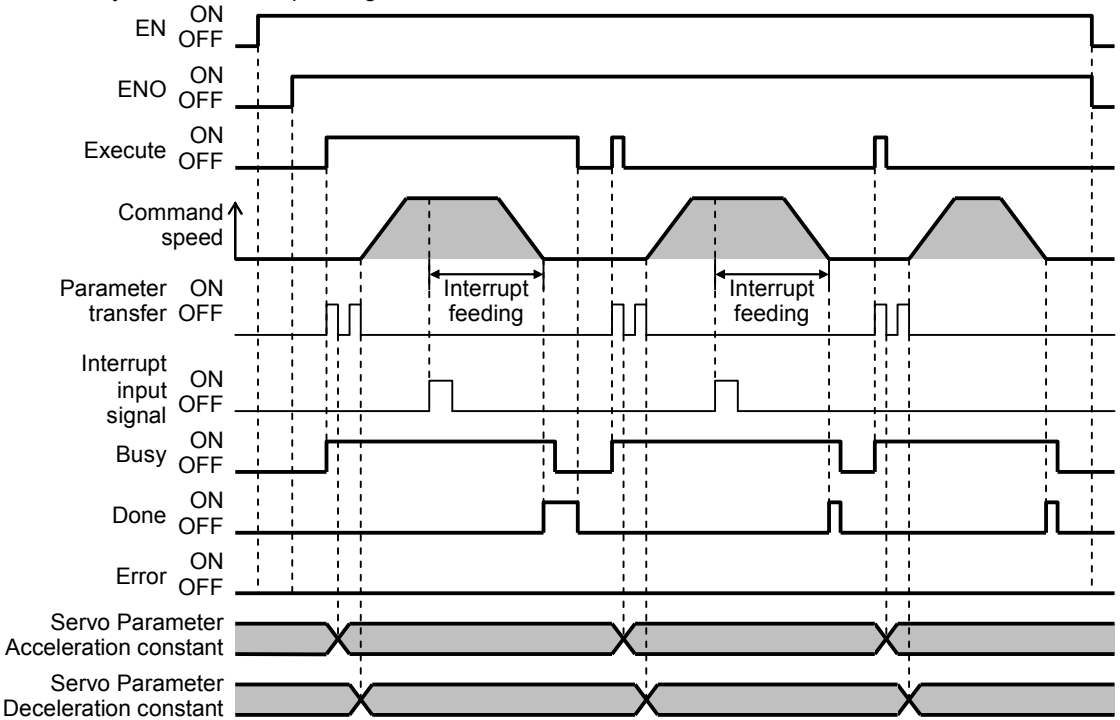

<b>NCF 014C</b>	<b>Move Absolute with Interrupt Feeding (REAL)</b> <b>_NCF014C_MoveAbsolute3_REAL</b>
---------------------	--

<b>Basic function</b>	Executes Interrupt Feeding with Move Absolute command. (Acceleration/Deceleration time setting, Busy attachment)																																																		
<b>Symbol</b>	<div style="display: flex; align-items: center;"> <div style="margin-right: 20px;"> <p>Always ON (P_On)</p> </div> <div style="border: 1px solid black; padding: 5px; margin-right: 20px;"> <table style="width: 100%; border-collapse: collapse;"> <tr> <td style="width: 50%; padding: 2px;">_NCF014C_MoveAbsolute3_REAL</td> <td style="width: 50%; padding: 2px;">(BOOL)</td> </tr> <tr> <td style="padding: 2px;">EN</td> <td style="padding: 2px;">(BOOL)</td> </tr> <tr> <td style="padding: 2px;">Unit No.</td> <td style="padding: 2px;">(INT)</td> </tr> <tr> <td style="padding: 2px;">Axis No.</td> <td style="padding: 2px;">(INT)</td> </tr> <tr> <td style="padding: 2px;">Start</td> <td style="padding: 2px;">(BOOL)</td> </tr> <tr> <td style="padding: 2px;">Position command</td> <td style="padding: 2px;">(REAL)</td> </tr> <tr> <td style="padding: 2px;">Speed command</td> <td style="padding: 2px;">(REAL)</td> </tr> <tr> <td style="padding: 2px;">Acceleration time</td> <td style="padding: 2px;">(REAL)</td> </tr> <tr> <td style="padding: 2px;">Deceleration time</td> <td style="padding: 2px;">(REAL)</td> </tr> </table> </div> <div style="margin-right: 20px;"> <table style="width: 50%; border-collapse: collapse;"> <tr> <td style="padding: 2px;">ENO</td> <td style="padding: 2px;">(BOOL)</td> </tr> <tr> <td style="padding: 2px;">Done</td> <td style="padding: 2px;">(BOOL)</td> </tr> <tr> <td style="padding: 2px;">Busy</td> <td style="padding: 2px;">(BOOL)</td> </tr> <tr> <td style="padding: 2px;">CommandAborted</td> <td style="padding: 2px;">(BOOL)</td> </tr> <tr> <td style="padding: 2px;">Error</td> <td style="padding: 2px;">(BOOL)</td> </tr> <tr> <td style="padding: 2px;">ErrorID</td> <td style="padding: 2px;">(WORD)</td> </tr> </table> </div> <div style="margin-right: 20px;"> </div> <div> <p>Positioning completed</p> <p>Busy flag</p> <p>Abort</p> <p>Error flag</p> <p>Error code</p> </div> </div>	_NCF014C_MoveAbsolute3_REAL	(BOOL)	EN	(BOOL)	Unit No.	(INT)	Axis No.	(INT)	Start	(BOOL)	Position command	(REAL)	Speed command	(REAL)	Acceleration time	(REAL)	Deceleration time	(REAL)	ENO	(BOOL)	Done	(BOOL)	Busy	(BOOL)	CommandAborted	(BOOL)	Error	(BOOL)	ErrorID	(WORD)																				
_NCF014C_MoveAbsolute3_REAL	(BOOL)																																																		
EN	(BOOL)																																																		
Unit No.	(INT)																																																		
Axis No.	(INT)																																																		
Start	(BOOL)																																																		
Position command	(REAL)																																																		
Speed command	(REAL)																																																		
Acceleration time	(REAL)																																																		
Deceleration time	(REAL)																																																		
ENO	(BOOL)																																																		
Done	(BOOL)																																																		
Busy	(BOOL)																																																		
CommandAborted	(BOOL)																																																		
Error	(BOOL)																																																		
ErrorID	(WORD)																																																		
<b>File name</b>	Lib\FBL\omronlib\PositionController\NCF\_NCF014C_MoveAbsolute3_REAL10.cxf																																																		
<b>Applicable models</b>	<table style="width: 100%; border-collapse: collapse;"> <tr> <td style="width: 20%; padding: 2px;">Position Control Unit</td> <td style="padding: 2px;">CJ1W-NCF71, CS1W-NCF71</td> </tr> <tr> <td style="padding: 2px;">CPU Unit</td> <td style="padding: 2px;">CS1*-CPU**H Unit Version 3.0 or later CJ1*-CPU**H Unit Version 3.0 or later CJ1M-CPU** Unit Version 3.0 or later CP1H</td> </tr> <tr> <td style="padding: 2px;">CX-Programmer</td> <td style="padding: 2px;">Version 5.0 or later</td> </tr> </table>	Position Control Unit	CJ1W-NCF71, CS1W-NCF71	CPU Unit	CS1*-CPU**H Unit Version 3.0 or later CJ1*-CPU**H Unit Version 3.0 or later CJ1M-CPU** Unit Version 3.0 or later CP1H	CX-Programmer	Version 5.0 or later																																												
Position Control Unit	CJ1W-NCF71, CS1W-NCF71																																																		
CPU Unit	CS1*-CPU**H Unit Version 3.0 or later CJ1*-CPU**H Unit Version 3.0 or later CJ1M-CPU** Unit Version 3.0 or later CP1H																																																		
CX-Programmer	Version 5.0 or later																																																		
<b>Languages in function block definitions</b>	Ladder programming																																																		
<b>Conditions for usage</b>	<p>The following conditions for usage should be the Position Control Unit version 1.2 or earlier. (It will not be required in the Position Control Unit version 1.3 or later)</p> <p>■CX-Programmer Setting</p> <p>The function blocks related to the Position Control Units will not operate if the area H512 or higher (default setting) is specified as the Non Retain Area through the Function block memory allocation. Make sure to change the memory area to unused area (DM or EM, for example) from the CX-Programmer. To change this value, click <b>PLC/Function Block Memory/Function Block Memory Allocation</b> from the Menu Bar.</p> <div style="border: 1px solid gray; padding: 5px; margin: 5px 0;"> <table style="width: 100%; border-collapse: collapse;"> <caption>Function Block Memory Allocation [NewPLC1]</caption> <thead> <tr> <th style="width: 20%;">FB Instance Area</th> <th style="width: 20%;">Start Address</th> <th style="width: 20%;">End Address</th> <th style="width: 20%;">Size</th> <th style="width: 20%;"></th> </tr> </thead> <tbody> <tr> <td>No Retain</td> <td>H512</td> <td>H1407</td> <td>896</td> <td>OK</td> </tr> <tr> <td>Retain</td> <td>H1408</td> <td>H1535</td> <td>128</td> <td>Cancel</td> </tr> <tr> <td>Timers</td> <td>T3072</td> <td>T4095</td> <td>1024</td> <td>Edit</td> </tr> <tr> <td>Counters</td> <td>C3072</td> <td>C4095</td> <td>1024</td> <td>Default</td> </tr> </tbody> </table> </div> <div style="border: 1px solid gray; padding: 5px; margin: 5px 0;"> <table style="width: 100%; border-collapse: collapse;"> <caption>Function Block Memory Allocation [NewPLC1]</caption> <thead> <tr> <th style="width: 20%;">FB Instance Area</th> <th style="width: 20%;">Start Address</th> <th style="width: 20%;">End Address</th> <th style="width: 20%;">Size</th> <th style="width: 20%;"></th> </tr> </thead> <tbody> <tr> <td>No Retain</td> <td>D32020</td> <td>D32767</td> <td>748</td> <td>OK</td> </tr> <tr> <td>Retain</td> <td>H1408</td> <td>H1535</td> <td>128</td> <td>Cancel</td> </tr> <tr> <td>Timers</td> <td>T3072</td> <td>T4095</td> <td>1024</td> <td>Edit</td> </tr> <tr> <td>Counters</td> <td>C3072</td> <td>C4095</td> <td>1024</td> <td>Default</td> </tr> </tbody> </table> </div> <div style="border: 1px solid gray; padding: 5px; margin: 5px 0;"> <p>Specify unused area. The required size varies depending on the used FB and the number of FBs. If an area being used in the ladder program is specified or sufficient free space cannot be found, the CX-Programmer will display a compile error.</p> </div> <p>For example, to use the memory area from D32020 to D32767 (748 words), specify the addresses as shown in the left.</p>	FB Instance Area	Start Address	End Address	Size		No Retain	H512	H1407	896	OK	Retain	H1408	H1535	128	Cancel	Timers	T3072	T4095	1024	Edit	Counters	C3072	C4095	1024	Default	FB Instance Area	Start Address	End Address	Size		No Retain	D32020	D32767	748	OK	Retain	H1408	H1535	128	Cancel	Timers	T3072	T4095	1024	Edit	Counters	C3072	C4095	1024	Default
FB Instance Area	Start Address	End Address	Size																																																
No Retain	H512	H1407	896	OK																																															
Retain	H1408	H1535	128	Cancel																																															
Timers	T3072	T4095	1024	Edit																																															
Counters	C3072	C4095	1024	Default																																															
FB Instance Area	Start Address	End Address	Size																																																
No Retain	D32020	D32767	748	OK																																															
Retain	H1408	H1535	128	Cancel																																															
Timers	T3072	T4095	1024	Edit																																															
Counters	C3072	C4095	1024	Default																																															

<p><b>Function description</b></p>	<p>The acceleration/deceleration time setting and Busy Output are added to the _NCF014_MoveAbsolute3_REAL in this FB.</p> <p>When the Start (Execute) turns ON, the Interrupt Feeding (Move Absolute) for the axis of the specified Unit No. (UnitNo) and Axis No. (Axis) is started using the specified Position command (Position), Speed command (Velocity), Acceleration time (Acceleration) and Deceleration time (Deceleration). (An Interrupt Feeding Designation Bit of the Axis Operating Output Memory Area is turned ON in the FB, so it does not need to be turned ON at the external ladder program.)</p> <p>When the Start (Execute) turns ON, the value set in Acceleration time (Acceleration) and Deceleration time (Deceleration) is written to "Acceleration constant" and "Deceleration constant" using the Transferring Servo Parameter function. Refer to the <i>Restrictions Other</i> for the details of Servo Parameter "Acceleration constant" and "Deceleration constant".</p> <p>Changing the Speed command (Velocity) during positioning by this FB will change the actual operation speed. Positioning is executed on the axis being positioned for an amount specified in the Servo Parameter, "Final travel distance for external positioning", when the external interrupt input signal is input. When an interrupt input signal is not input, an axis is moved to the position specified in "Position command (Position)".</p>  <p>The Positioning completed (Done) is turned ON when the positioning operation for the FB has been completed. This Flag is also turned ON when the positioning operation is completed without the interrupt feeding signal input. This flag will not be turned ON if the positioning operation is canceled because another operation has been started from a different instance, for a deceleration stop, or because an error has occurred.</p> <p>The Busy flag (Busy) will be set when the Start (Execute) is turned ON.</p> <p>The Busy flag (Busy) will be reset when any of the Positioning completed (Done), Abort (CommandAborted), or Error flag (Error) is turned ON.</p> <p>Even if an error occurs when the input variable is out of the range, etc., the Busy flag (Busy) will be set for at least one cycle.</p> <p>The Error flag (Error) will be turned ON and the Error code (ErrorID) will be output if an error occurs for the FB. This will not occur for error in other FBs or other instances of the FB.</p> <p>These statuses (Done/CommandAborted/Error/ErrorID) will be reset when the Start (Execute) turns OFF. If the Start (Execute) turns OFF before the positioning operation has been completed, the status will be set for at least one cycle when corresponding conditions have occurred.</p> 
<p><b>Kind of FB definition</b></p>	<p>Always execution type.          Connect the EN input to the Always ON Flag (P_On).          The same instance cannot be used in two or more places.</p>

<b>FB precautions</b>	<ul style="list-style-type: none"><li>▪ Executing this FB during the positioning operation will cause a multistart error.</li><li>▪ Positioning operation will be performed to the absolute position specified in Position command (Position) from the point at which the last execution was started when executing this FB during the Speed Control or Torque Control. Refer to the <i>Related Manuals</i> for details.</li><li>▪ The setting of Axis Parameters and Servo Parameters is required for executing the Interrupt Feeding operation. Refer to 9-5 Interrupt Feeding of the Operation Manual, W426-E1, in the <i>Related Manuals</i> for details.</li></ul>
<b>EN input condition</b>	<ul style="list-style-type: none"><li>▪ Connect the EN input to the Always ON Flag (P_On). If another bit is connected to EN, the FB outputs will be held when the connected bit turns OFF.</li></ul>

**Restrictions  
Other**

- Changing the Speed command (Velocity) during positioning by this FB will change the actual operation speed. However, the speed will not be changed if the Speed command (Velocity) is less than  $-2.147483e+009$  or exceeds  $+2.147483e+009$ .
  - Ex.1) When changing the Speed command value  $+1000.0(+1000)$  to  $+2.147483e+009$  during the operation: The speed command value for the Position Control Unit is changed to  $+2.147483e+009(+2147483000)$ . Some Position Control Units may cause an error.
  - Ex.2) When changing the Speed command value  $+1000.0(+1000)$  to  $+2.147484e+009$  during the operation: The Speed command value for the Position Control Unit remains  $+1000.0(+1000)$  without any change.
- The Acceleration/deceleration constants are calculated based on "Speed command (Velocity)" "Acceleration time (Acceleration)" and "Deceleration time (Deceleration)" in this FB. If the calculated value is out of Servo Parameter range, it will be adjusted to be within the range (1 to 65535). In this case, the specified acceleration/deceleration time may be altered.

(Reference) Acceleration/Deceleration constant setting range of Servo Drive

Drive	PRM No.	Parameter name	Size	Unit	Setting range
W-Series	Pn80B	Second-step linear acceleration constant	2	$\times 10000$ command units/s <sup>2</sup>	1 to 65535
	Pn80E	Second-step linear deceleration constant	2	$\times 10000$ command units/s <sup>2</sup>	1 to 65535
G-Series	Pn107 (80B)	Linear Acceleration constant	2	$\times 10000$ command units/s <sup>2</sup>	0 to 65535 (Note)
	Pn10A (80E)	Linear deceleration constant	2	$\times 10000$ command units/s <sup>2</sup>	0 to 65535 (Note)

(Note) Setting 0 automatically changes to 1.

- The following cannot be specified for this FB: "Acceleration/deceleration curve designation", "Forward rotation current limit designation" and "Reverse rotation current limit designation". If these functions are required, specify them in advance outside the FB.
- This FB may act differently according to unit versions of the Position Control Units when executing this FB during the Origin Search operation.

Earlier than 2.0	A Multistart error occurs right after parameters are transferred. Do not execute this FB during the Origin search operation.
2.0 or later	The parameter transferring status is hold until the Origin search is completed. After the completion, the Move Absolute command is executed.

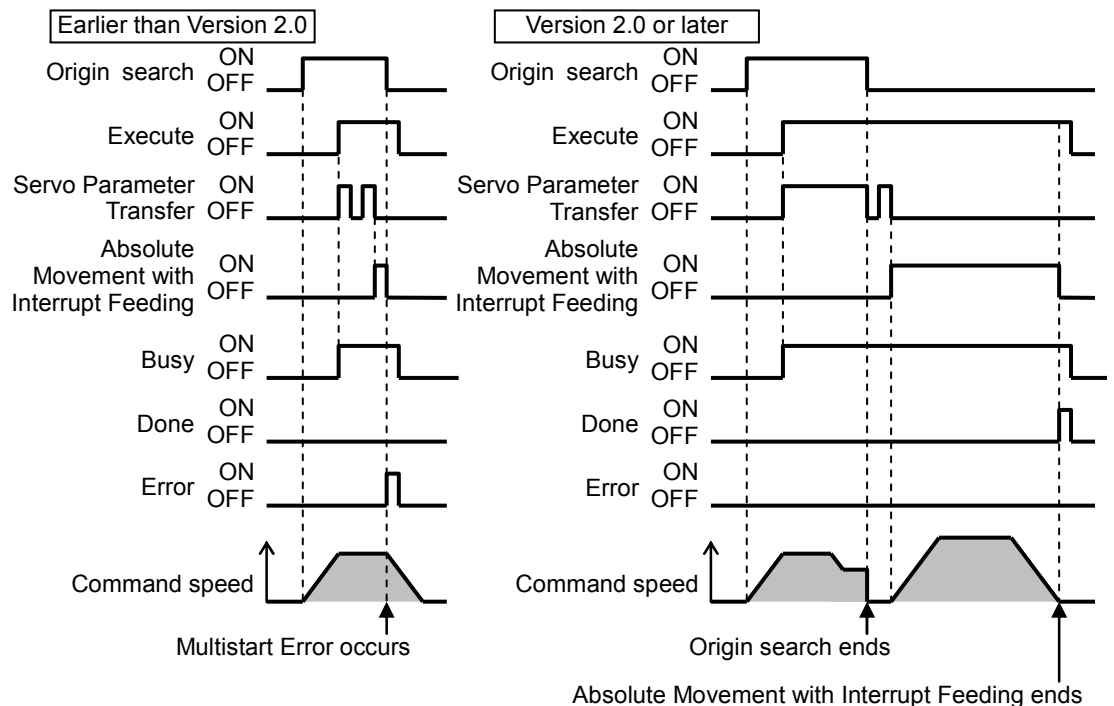

- This FB uses Unit Error Reset, Write Data, Read Data and Save Data Bits of the Position Control Unit (see Note). Therefore, do not turn these bits ON or OFF between the period from the rising edge of EN to the rising edge of ENO. For the same reason, do not use these bits for coil outputs (OUT commands).
- The output variable of FB may not change even if EN is turned ON. In that case, check if any of Unit Error Reset, Write Data, Read Data and Save Data Bit is left ON.
- This FB uses the Absolute Movement and the Interrupt Feeding Bit in the Axis Operating Output Memory Areas. Therefore, do not turn these bits ON or OFF until the operation is completed. For the same reason, do not use these bits for coil outputs (OUT commands).

**Note:**

For calculation of bit addresses, these bits are referenced in this FB in the first execution of each instance, and when changing "Unit No. (UnitNo)", "Axis No. (Axis)" of the input variable and set "Start (Execute)".

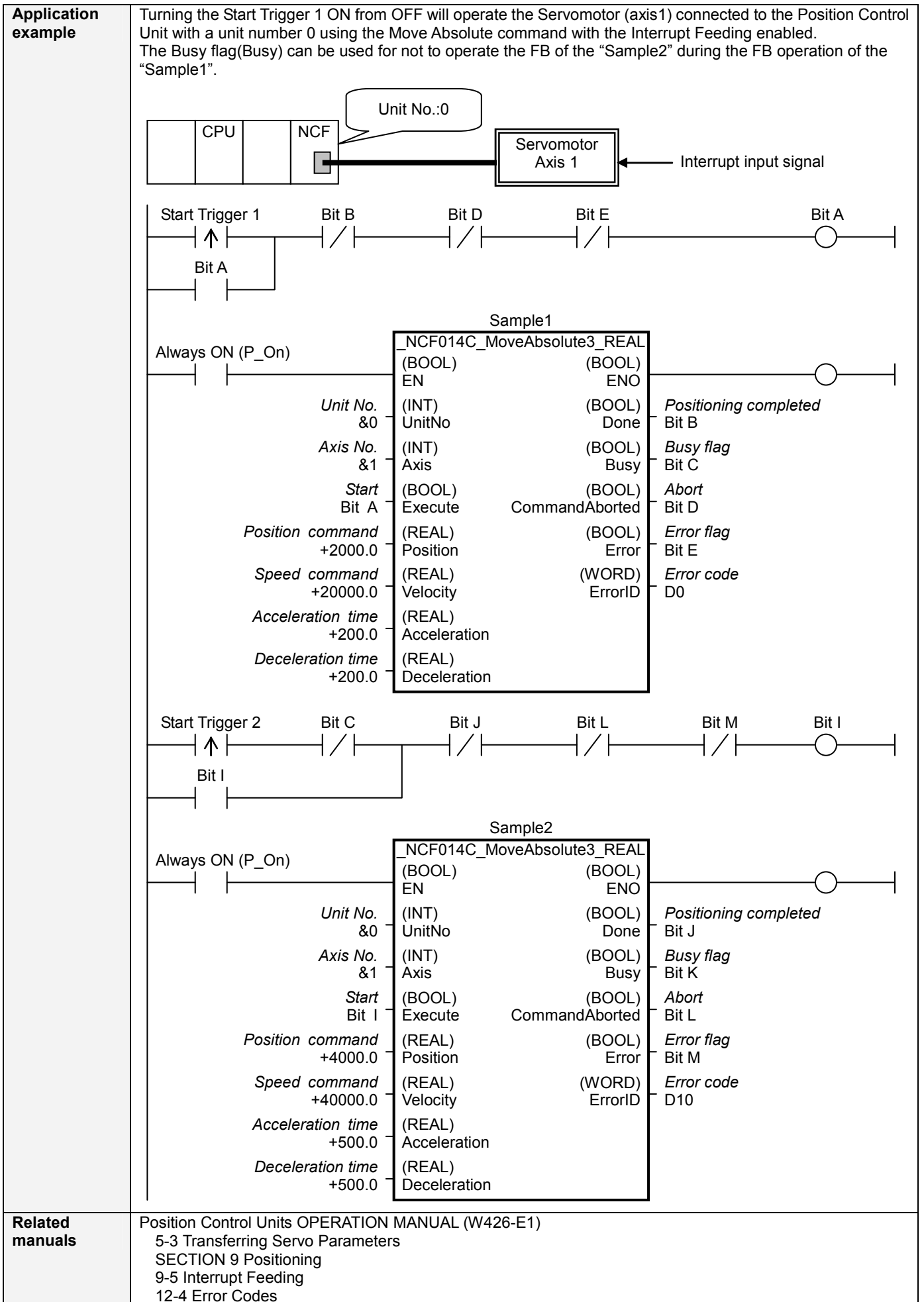

## ■Variable Tables

### Input Variables

Name	Variable name	Data type	Default	Range	Description
EN	EN	BOOL			1 (ON): FB started 0 (OFF): FB not started
Unit No.	UnitNo	INT	&0	&0 to &15	Specify the unit number.
Axis No.	Axis	INT	&1	&1 to &16	Specify the axis number.
Start	Execute	BOOL	0(OFF)		↑ : Starts the absolute move.
Position command	Position	REAL	+0.0	-2.147483e+009 to +2.147483e+009	Specify the target position. Unit: Command units/s
Speed command	Velocity	REAL	+0.0	+0.0 to +2.147483e+009	Specify the target speed. Unit: Command units/s Changing the value while this FB is in operation will change the actual operating speed.
Acceleration time	Acceleration	REAL	+0.0	+0.0 to +65535.0	Specify the acceleration time for the speed specified in "Speed command (Velocity)". Unit: ms
Deceleration time	Deceleration	REAL	+0.0	+0.0 to +65535.0	Specify the deceleration time for the speed specified in "Speed command (Velocity)". Unit: ms

### Output Variables

Name	Variable name	Data type	Range	Description
ENO	ENO	BOOL		1 (ON): FB operating normally 0 (OFF): FB not operating normally <ul style="list-style-type: none"> <li>• FB not started</li> <li>• Input variable out of the range</li> <li>• FB ended with error</li> <li>• Common Parameters could not be read</li> </ul>
Positioning completed	Done	BOOL		Turns ON when the positioning operation has been completed.
Busy flag	Busy	BOOL		1 (ON) indicates that the FB is in progress.
Abort	CommandAborted	BOOL		1 (ON): Aborted It will be aborted when any of the following conditions is met during operation <ul style="list-style-type: none"> <li>• Turns ON when the other Move command done (Duplicate Move).</li> <li>• Stopped with Declaration Stop or Emergency Stop.</li> <li>• Executed Servo Unlock, Deviation Counter Reset on an operating axis.</li> <li>• Attempted to execute FB while Servo Unlock, Deceleration Stop, Emergency Stop or Deviation Counter Reset Bit is ON.</li> <li>• Detected the Stop Execution Flag is ON.</li> <li>• The Absolute Movement Bit is changed by the other FB during Absolute Movement in operation.</li> </ul>
Error flag	Error	BOOL		Turns ON when an error has occurred in the FB.
Error code	ErrorID	WORD		Returns the error code when an error has occurred in the FB. Refer to the <i>Related Manuals</i> for details on errors. A code of #0000 will be returned if any of the following conditions is satisfied. <ul style="list-style-type: none"> <li>• Input variable is out of range.</li> <li>• The common parameters of the Position Control Units are out of range.</li> <li>• Not established communications with a specified axis.</li> <li>• The Write Servo Parameter Bit is changed by the other FB during writing Servo parameters.</li> </ul>

### ■Version History

Version	Date	Contents
1.01	2007.11.	Original production

### ■Note

This document explains the function of the function block.

It does not provide information of restrictions on the use of Units and Components or combination of them. For actual applications, make sure to read the operation manuals of the applicable products.