

CPU -005A	BCD OFF Delay: _CPU005A_TOF_BCD	
Basic function	Turns OFF the output a specified time after the input turns OFF.	
Symbol		
File name	Lib\FLB\omronlib\PLC\CPU_CPU005A_TOF_BCD10.cxf	
Applicable models	CPU Unit	CS1*-CPU**H Unit version 3.0 or higher CJ1*-CPU**H Unit version 3.0 or higher CJ1M-CPU** Unit version 3.0 or higher CP1H CP1L
	CX-Programmer	Version 5.0 or higher
Conditions for usage	PLC Properties <ul style="list-style-type: none"> The PV update method for timers and counters must be set to BCD in the PLC Setup. A compiling error will occur if BCD mode is not set. The mode can be set in the PLC Properties in the CX-Programmer.  Shared Resources <ul style="list-style-type: none"> Timers 	
Function description	When PLC mode changes from Program mode. ENO turns OFF. ENO is turned ON when the Input turns ON. The delay timer is started when Input turns OFF. When the time set for the Delay time has expired, ENO is turned OFF.  PLC mode changes from PROGRAM mode.	
EN input condition	Connect the EN input to the Always ON Flag (P_On).	
Restrictions Input variables	<ul style="list-style-type: none"> If the input variables are out of range, the ENO Flag will turn OFF and the FB will not be processed. The Delay time input variable must be BCD between #0000 and #9999. If a setting is not within range, ENO is turned OFF. 	

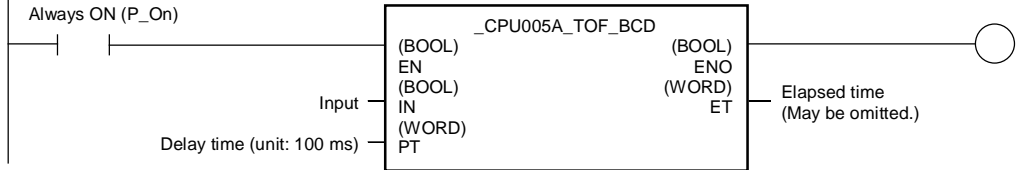
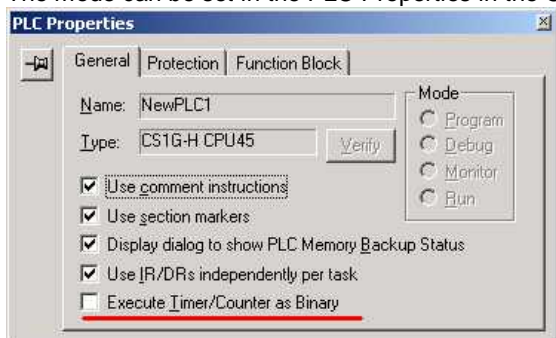
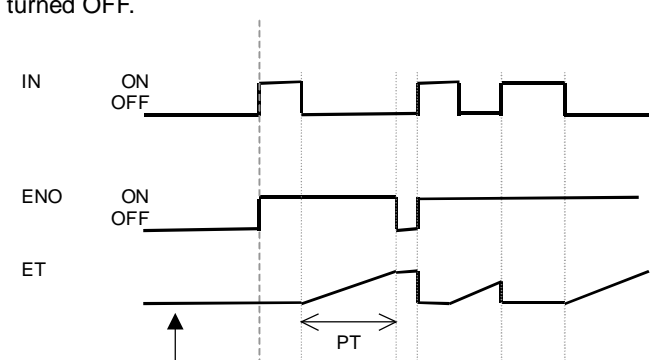
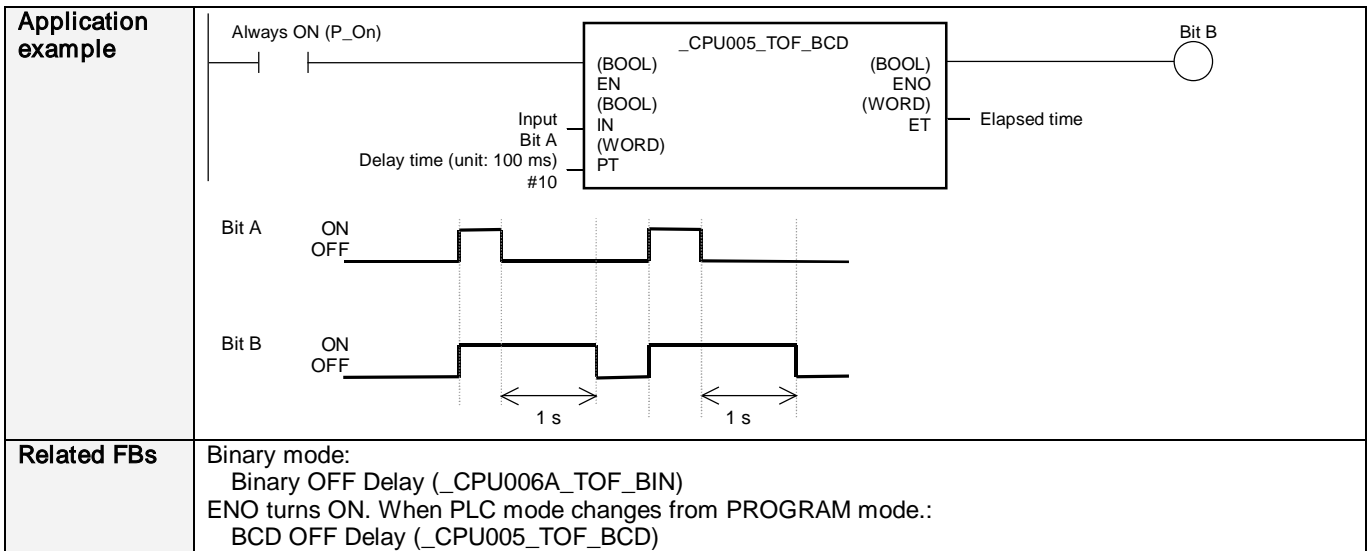

■ Variable Tables

Input Variables

Name	Variable name	Data type	Default	Range	Description
EN	EN	BOOL			1 (ON): FB started. 0 (OFF): FB not started.
Input	IN	BOOL			Turn ON to start timing.
Delay time	PT	WORD		#0000 to #9999	Specify the delay time (unit: 100 ms). For example, #30 means 3 seconds.

Output Variables

Name	Variable name	Data type	Range	Description
ENO	ENO	BOOL		Turns ON when the Input turns ON and turns OFF a specified time after the Input turns OFF.
Elapsed time (May be omitted.)	ET	WORD		Outputs the time that Input was ON (unit: 100 ms).

■ Version History

Version	Date	Contents
1.00	2007.12.	Original production

Note

This manual is a reference that explains the function block functions.

It does not explain the operational limitations of Units, components, or combinations of Units and components. Always read and understand the Operation Manuals for the system's Units and other components before using them.