

EMC Test Report

Client Name : Shenzhen Samkoon Technology Corporation Ltd.
Address : Building 7, Fashion Industry Park, E'Bu Town, ShenShan
Special cooperation zone, Shenzhen City, Guangdong
Province
Product Name : Motion controller
Date : Mar. 30, 2020



Shenzhen Anbotek Compliance Laboratory Limited

Contents

1. General Information.....	5
1.1. Client Information.....	5
1.2. Description of Device (EUT).....	5
1.3. Auxiliary Equipment Used During Test.....	5
1.4. Description of Test Mode.....	6
1.5. Test Summary.....	6
1.6. Test Equipment List.....	7
1.7. Description of Test Facility.....	9
1.8. EMS Performance Criteria.....	9
2. Power Line Conducted Emission Test (AC Mains Power Ports).....	10
2.1. Test Standard and Limit.....	10
2.2. Test Setup.....	10
2.3. EUT Configuration on Measurement.....	10
2.4. Operating Condition of EUT.....	10
2.5. Test Procedure.....	11
2.6. Test Results.....	11
3. Power Line Conducted Emission Test (Wired Network Ports).....	14
3.1. Test Standard and Limit.....	14
3.2. Test Setup.....	14
3.3. EUT Configuration on Measurement.....	14
3.4. Operating Condition of EUT.....	14
3.5. Test Procedure.....	15
3.6. Test Results.....	15
4. Radiated Emission Test.....	17
4.1. Test Standard and Limit.....	17
4.2. Test Setup.....	17
4.3. EUT Configuration on Measurement.....	17
4.4. Operating Condition of EUT.....	18
4.5. Test Procedure.....	18
4.6. Test Results.....	18
5. Electrostatic Discharge Immunity Test.....	21
5.1. Test Standard and Level.....	21
5.2. Test Setup.....	21
5.3. EUT Configuration on Measurement.....	21
5.4. Operating Condition of EUT.....	21
5.5. Test Procedure.....	22
5.6. Test Results.....	22
6. RF Field Strength Susceptibility Test.....	24
6.1. Test Standard and Level.....	24

- 6.2. Test Setup..... 24
- 6.3. EUT Configuration on Measurement..... 25
- 6.4. Operating Condition of EUT..... 25
- 6.5. Test Procedure..... 25
- 6.6. Measuring Results..... 25
- 7. Electrical Fast Transient/Burst Immunity Test..... 27
 - 7.1. Test Standard and Level..... 27
 - 7.2. Test Setup..... 27
 - 7.3. EUT Configuration on Measurement..... 27
 - 7.4. Operating Condition of EUT..... 27
 - 7.5. Test Procedure..... 28
 - 7.6. Test Results..... 28
- 8. Surge Immunity Test..... 30
 - 8.1. Test Standard and Level..... 30
 - 8.2. Test Setup..... 30
 - 8.3. EUT Configuration on Measurement..... 30
 - 8.4. Operating Condition of EUT..... 30
 - 8.5. Test Procedure..... 31
 - 8.6. Test Results..... 31
- 9. Injected Currents Susceptibility Test..... 33
 - 9.1. Test Standard and Level..... 33
 - 9.2. Test Setup..... 33
 - 9.3. EUT Configuration..... 33
 - 9.4. Operating Condition of EUT..... 33
 - 9.5. Test Procedure..... 34
 - 9.6. Test Results..... 34
- APPENDIX I -- TEST SETUP PHOTOGRAPH..... 36
- APPENDIX II -- EXTERNAL PHOTOGRAPH..... 40
- APPENDIX III -- INTERNAL PHOTOGRAPH..... 43

TEST REPORT

Applicant : Shenzhen Samkoon Technology Corporation Ltd.
Manufacturer : Shenzhen Samkoon Technology Corporation Ltd.
Product Name : Motion controller
Model No. : CR100-CPXT, CR100-CMMM, CR100-CPMM, CR100-CPXX, CR100-CPTT,
CR100-CPXT, CR100-CPXA, CR100-CPTA, CR100-C(a)
(a) the model number contains suffixes that can be blank or any
combination of Numbers and or symbols to represent the
customer identity
Trade Mark : Samkoon
Rating(s) : Input: DC, 24V
**Test Standard(s) : EN 55032: 2015;
EN 55035: 2017;
(IEC 61000-4-2; IEC 61000-4-3; IEC 61000-4-4;
IEC 61000-4-5; IEC 61000-4-6)**

The device described above is tested by Shenzhen Anbotek Compliance Laboratory Limited to determine the maximum emission levels emanating from the device and the severe levels of the device can endure and its performance criterion. The measurement results are contained in this test report and Shenzhen Anbotek Compliance Laboratory Limited is assumed full of responsibility for the accuracy and completeness of these measurements. Also, this report shows that the EUT (Equipment Under Test) is technically compliant with the EN 55032, EN 61000-3-2, EN 61000-3-3, EN 55035 requirements.

This report applies to above tested sample only and shall not be reproduced in part without written approval of Shenzhen Anbotek Compliance Laboratory Limited.

Date of Receipt: Mar. 06, 2020

Date of Test: Mar. 06~28, 2020

Prepared By:

Jane Ding

(Engineer / Jane Ding)

Reviewer:

Well Wang

(Supervisor / Well Wang)

Approved & Authorized Signer:

Tom Chen

(Manager / Tom Chen)

1. General Information

1.1. Client Information

Applicant	:	Shenzhen Samkoon Technology Corporation Ltd.
Address	:	Building 7, Fashion Industry Park, E'Bu Town, ShenShan Special cooperation zone, Shenzhen City, Guangdong Province
Manufacturer	:	Shenzhen Samkoon Technology Corporation Ltd.
Address	:	Building 7, Fashion Industry Park, E'Bu Town, ShenShan Special cooperation zone, Shenzhen City, Guangdong Province
Factory	:	Shenzhen Samkoon Technology Corporation Ltd.
Address	:	Building 7, Fashion Industry Park, E'Bu Town, ShenShan Special cooperation zone, Shenzhen City, Guangdong Province

1.2. Description of Device (EUT)

Product Name	:	Motion controller
Model No.	:	CR100-CPXT, CR100-CMMM, CR100-CPMM, CR100-CPXX, CR100-CPTT, CR100-CPXT, CR100-CPXA, CR100-CPTA, CR100-C(a) (a) the model number contains suffixes that can be blank or any combination of Numbers and or symbols to represent the customer identity (Note: All samples are the same except the model number & appearance, so we prepare "CR100-CPXT" for test only.)
Trade Mark	:	Samkoon
Test Power Supply	:	DC 24V
Test Sample No.	:	1-1-1
Product Description	:	Adapter:
Remark: (1) For a more detailed features description, please refer to the manufacturer's specifications or the User's Manual.		

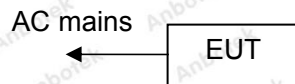
1.3. Auxiliary Equipment Used During Test

N/A	:	
-----	---	--

1.4. Description of Test Mode

Pretest Mode	Description
Mode 1	On

For Mode 1 Block Diagram of Test Setup



1.5. Test Summary

Test Items	Test Mode	Status
Power Line Conducted Emission Test (150KHz To 30MHz)	Mode 1	P
Communication Line Conducted Emission Test (150KHz To 30MHz)	Mode 1	P
Radiated Emission Test (30MHz To 1000MHz)	Mode 1	P
Electrostatic Discharge immunity Test	Mode 1	P
RF Field Strength susceptibility Test	Mode 1	P
Electrical Fast Transient/Burst Immunity Test	Mode 1	P
Surge Immunity Test	Mode 1	P
Injected Currents Susceptibility Test	Mode 1	P
Magnetic Field Susceptibility Test	/	N
Voltage Dips and Interruptions Test	/	N
P) Indicates "PASS". N) Indicates "Not applicable".		

1.6. Test Equipment List

Conducted Emission Measurement

Item	Equipment	Manufacturer	Model No.	Serial No.	Last Cal.	Cal. Interval
1.	L.I.S.N. Artificial Mains Network	Rohde & Schwarz	ENV216	100055	Nov. 04, 2019	1 Year
2.	L.I.S.N. Artificial Mains Network	Schwarzbeck	NSLK 8127	8127386	Nov. 04, 2019	1 Year
3.	EMI Test Receiver	Rohde & Schwarz	ESCI	100627	Nov. 04, 2019	1 Year
4.	RF Switching Unit	Compliance Direction	RSU-M2	38303	Nov. 04, 2019	1 Year
5.	Software Name EZ-EMC	Ferrari Technology	ANB-03A	N/A	N/A	N/A

Telecom Port Conduct Emission Measurement

Item	Equipment	Manufacturer	Model No.	Serial No.	Last Cal.	Cal. Interval
1.	ISN	Schwarzbeck	NTFM 8158	#172	Nov. 04, 2019	1 Year
2.	EMI Test Receiver	Rohde & Schwarz	ESCI	100627	Nov. 04, 2019	1 Year
3.	RF Switching Unit	Compliance Direction	RSU-M2	38303	Nov. 04, 2019	1 Year
4.	Software Name EZ-EMC	Ferrari Technology	ANB-03A	N/A	N/A	N/A

Radiated Emission Measurement

Item	Equipment	Manufacturer	Model No.	Serial No.	Last Cal.	Cal. Interval
1.	EMI Test Receiver	Rohde & Schwarz	ESCI	100627	Nov. 04, 2019	1 Year
2.	Pre-amplifier	Schwarzbeck	BBV-9745	9745-075	Nov. 04, 2019	1 Year
3.	Bilog Broadband Antenna	SCHWARZBECK	VULB 9163	01109	Nov. 01, 2019	1 Year
4.	Software Name EZ-EMC	Ferrari Technology	EMEC-3A1	N/A	N/A	N/A

Electrostatic Discharge Measurement

Item	Equipment	Manufacturer	Model No.	Serial No.	Last Cal.	Cal. Interval
1.	ESD Simulators	3Ctest	EDS-30T	ES0131505	Nov. 06, 2019	1 Year

Electrical Fast Transient/Burst Immunity Measurement

Item	Equipment	Manufacturer	Model No.	Serial No.	Last Cal.	Cal. Interval
1.1	EFT Burst Simulator	PRIMA	EFT61004B	PR10114282	Nov. 04, 2019	1 Year
1.2	EFT-Clamp	PRIMA	EFT-Clamp	/	Nov. 04, 2019	1 Year
2.1	EFT Burst Simulator	TESEQ	NSG 3060	1480	Nov. 04, 2019	1 Year
2.2	CDN	TESEQ	CDN 3061	1408	Nov. 04, 2019	1 Year

R/S Immunity Measurement

Item	Equipment	Manufacturer	Model No.	Serial No.	Last Cal.	Cal. Interval
1	Signal Generator	Agilent	N5182A	MY4818065 6	Nov. 04, 2019	1 Year
2	Amplifier	Micotoop	MPA-80-100 0-250	MPA190309 6	Nov. 04, 2019	1 Year
3	Amplifier	Micotoop	MPA-1000-6 000-100	MPA190312 2	Nov. 04, 2019	1 Year
4	Log-Periodic Antenna	Schwarzbeck	VULP9118E	00992	Aug. 17, 2018	3 Year
5	Horn Antenna	Instruments corporation	GTH-0118	351600	Nov. 01, 2019	1 Year
6	Power Sensor	Agilent	E9301A	MY4149890 6	Nov. 04, 2019	1 Year
7	Power Sensor	Agilent	E9301A	MY4149808 8	Nov. 04, 2019	1 Year
8	Power Meter	Agilent	E4419B	GB4020290 9	Nov. 04, 2019	1 Year
9	Field Probe	ETS-Lindgren	HI-6006	00212747	Apr. 20, 2017	3 Year
10	software	EMtrace	EM 3	N/A	N/A	N/A

Surge Measurement

Item	Equipment	Manufacturer	Model No.	Serial No.	Last Cal.	Cal. Interval
1.	Surge Generator	TESEQ	NSG 3060	1480	Nov. 04, 2019	1 Year
2.	CDN	TESEQ	CDN 3061	1408	Nov. 04, 2019	1 Year
3.	Telecom port surge generator	PMI	TW101	190411	Apr.17,2019	1 Year

Injected Currents Susceptibility Measurement

Item	Equipment	Manufacturer	Model No.	Serial No.	Last Cal.	Cal. Interval
1.	C/S Conducted Immunity Test System	FRANKONIA	CIT-10	126A1196/20 12	Nov. 04, 2019	1 Year
2.	CDN	FRANKONIA	CDN - M2+ M3	A2210178/20 12	Nov. 04, 2019	1 Year
3.	6dB Attenuator	FRANKONIA	DAM 26W	1172202	Nov. 04, 2019	1 Year
4.	CIT-10	FRANKONIA	Version1.1.7	N/A	N.A	N/A
5.	EM-Clamp	FRANKONIA	EMCL-20	18101728-01 03	May.19,2019	1 Year

1.7. Description of Test Facility

The test facility is recognized, certified, or accredited by the following organizations:

FCC-Registration No.: 184111

Shenzhen Anbotek Compliance Laboratory Limited, EMC Laboratory has been registered and fully described in a report filed with the (FCC) Federal Communications Commission. The acceptance letter from the FCC is maintained in our files. Registration No. 184111, September 27, 2019.

ISED-Registration No.: 8058A

Shenzhen Anbotek Compliance Laboratory Limited, EMC Laboratory has been registered and fully described in a report filed with the (ISED) Innovation, Science and Economic Development Canada. The acceptance letter from the ISED is maintained in our files. Registration 8058A, March 07, 2019.

Test Location

Shenzhen Anbotek Compliance Laboratory Limited.
1/F, Building D, Sogood Science and Technology Park, Sanwei community, Hangcheng Street, Bao'an District, Shenzhen, Guangdong, China.518128

1.8. EMS Performance Criteria

- √ A: Normal performance within the specification limits
- √ B: Temporary degradation or loss of function or performance which is self-recoverable
- √ C: Temporary degradation or loss of function or performance which requires operator intervention or system reset
- √ D: Degradation or loss of function which is not recoverable due to damage of equipment (components) or software, or loss of data

Note: The manufacturer's specification may define effects on the EUT which may be considered insignificant, and therefore acceptable.

This classification may be used as a guide in formulating performance criteria, by committees responsible for generic, product and product-family standards, or as a framework for the agreement on performance criteria between the manufacturer and the purchaser, for example where no suitable generic, product or product-family standard exists.

2. Power Line Conducted Emission Test (AC Mains Power Ports)

2.1. Test Standard and Limit

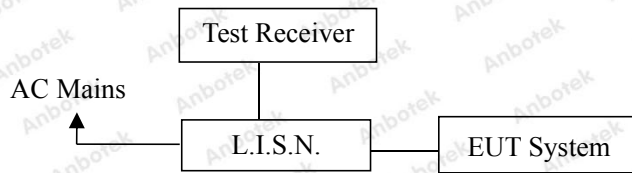
Test Standard	EN 55032
---------------	----------

Limits for conducted emissions

Test Limit	Frequency (MHz)	At mains terminals (dB μ V)	
		Quasi-peak Level	Average Level
	0.15 ~ 0.50	66.0 ~ 56.0 *	56.0 ~ 46.0 *
	0.50 ~ 5.00	56.0	46.0
	5.00 ~ 30.00	60.0	50.0

Remark: (1) The lower limit shall apply at the transition frequencies.
 (2) The limit decreases linearly with the logarithm of the frequency in the range 0.15MHz to 0.50MHz.

2.2. Test Setup



2.3. EUT Configuration on Measurement

The following equipments are installed on conducted emission measurement to meet EN 55032 requirements and operating in a manner which tends to maximize its emission characteristics in a normal application.

2.4. Operating Condition of EUT

- 2.4.1. Setup the EUT as shown in Section 2.2.
- 2.4.2. Turn on the power of all equipments.
- 2.4.3. Let the EUT work in test mode and measure it.

2.5. Test Procedure

The EUT is put on the plane 0.8 m high above the ground by insulating support and connected to the AC mains through Line Impedance Stability Network(L.I.S.N). This provided a 50ohm coupling impedance for the tested equipments. Both sides of AC line are investigated to find out the maximum conducted emission according to the EN55032 regulations during conducted emission measurement.

The bandwidth of the field strength meter (R&S Test Receiver ESCI) is set at 9kHz in 150kHz~30MHz.

The frequency range from 150kHz to 30MHz is investigated for AC mains.

All the test results are listed in Section 2.6.

2.6. Test Results

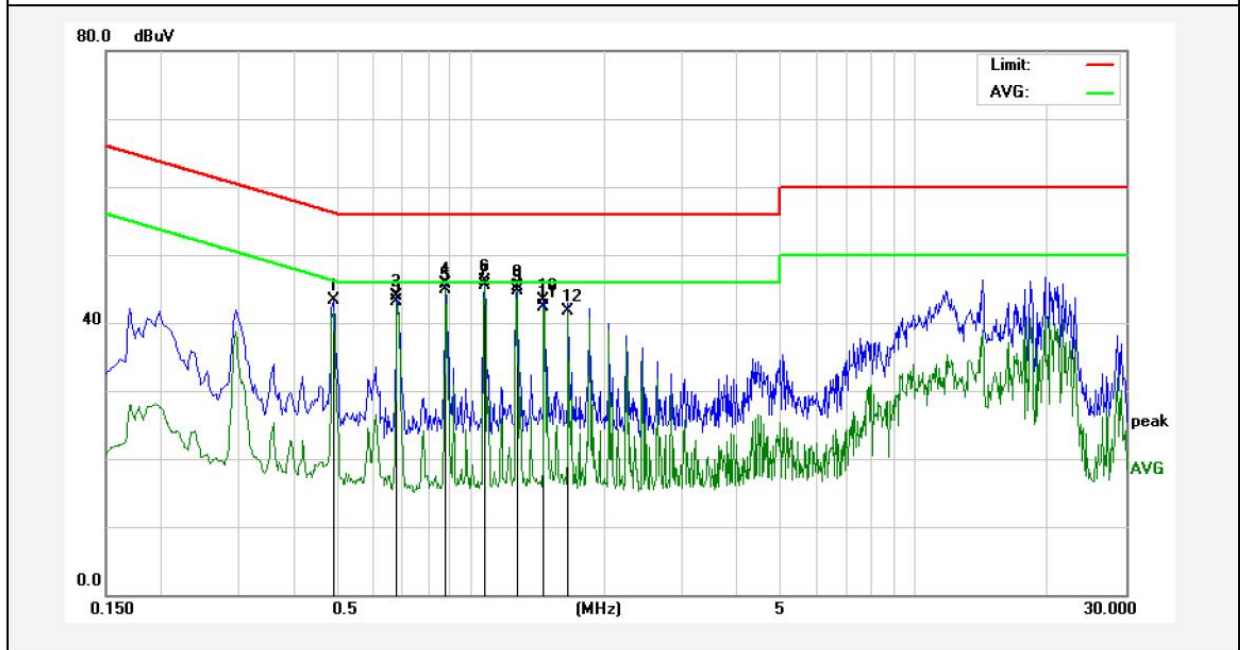
PASS

The test curves are shown in the following pages.



Conducted Emission Test Data

Test Site: 1# Shielded Room
 Test Specification: DC 24V
 Comment: +
 Temp.: 26°C Hum.: 53%

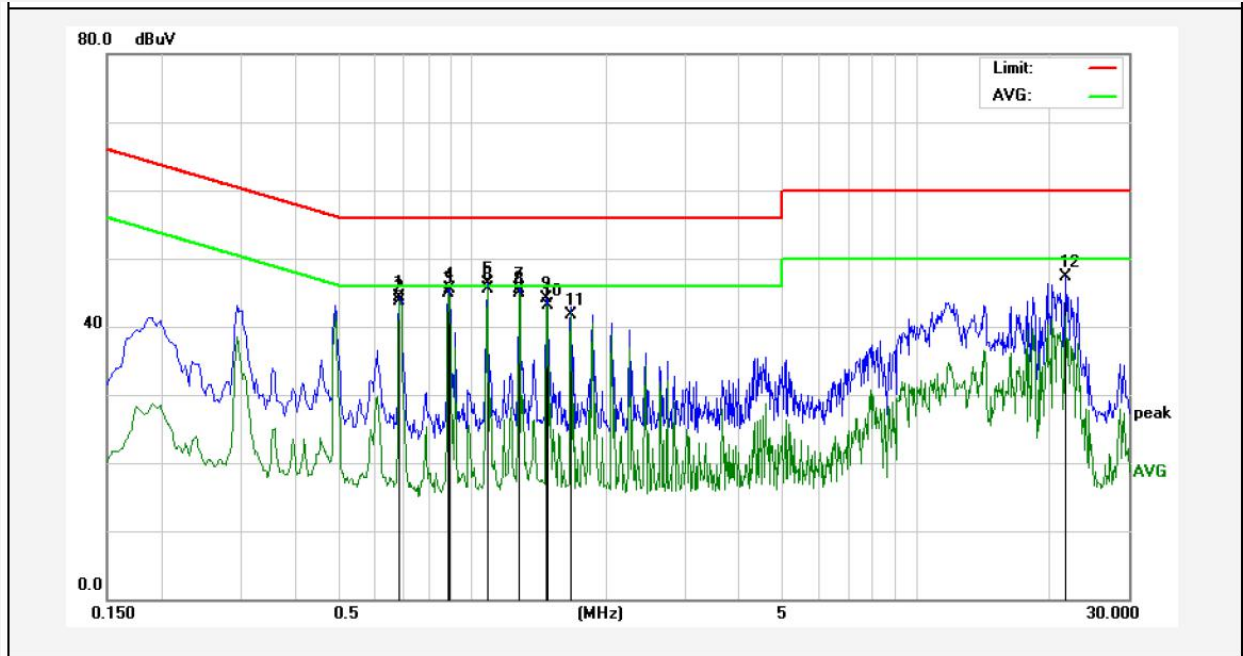


No.	Freq. (MHz)	Reading (dBuV)	Factor (dB)	Result (dBuV)	Limit (dBuV)	Over Limit (dB)	Detector	Remark
1	0.4900	23.25	19.98	43.23	56.17	-12.94	QP	
2	0.6820	23.90	20.03	43.93	56.00	-12.07	QP	
3	0.6820	23.17	20.03	43.20	46.00	-2.80	AVG	
4	0.8780	25.58	20.09	45.67	56.00	-10.33	QP	
5	0.8780	24.84	20.09	44.93	46.00	-1.07	AVG	
6	1.0740	25.93	20.12	46.05	56.00	-9.95	QP	
7	1.0740	25.32	20.12	45.44	46.00	-0.56	AVG	
8	1.2700	25.18	20.13	45.31	56.00	-10.69	QP	
9	1.2700	24.53	20.13	44.66	46.00	-1.34	AVG	
10	1.4620	23.26	20.13	43.39	56.00	-12.61	QP	
11	1.4620	22.23	20.13	42.36	46.00	-3.64	AVG	
12	1.6580	21.56	20.13	41.69	46.00	-4.31	AVG	

Note: Result=Reading+Factor Over Limit=Result-Limit

Conducted Emission Test Data

Test Site: 1# Shielded Room
 Test Specification: DC 24V
 Comment: -
 Temp.: 26°C Hum.: 53%



No.	Freq. (MHz)	Reading (dBuV)	Factor (dB)	Result (dBuV)	Limit (dBuV)	Over Limit (dB)	Detector	Remark
1	0.6860	24.29	20.04	44.33	56.00	-11.67	QP	
2	0.6860	23.62	20.04	43.66	46.00	-2.34	AVG	
3	0.8820	24.80	20.09	44.89	46.00	-1.11	AVG	
4	0.8860	25.38	20.09	45.47	56.00	-10.53	QP	
5	1.0780	26.15	20.12	46.27	56.00	-9.73	QP	
6	1.0780	25.33	20.12	45.45	46.00	-0.55	AVG	
7	1.2740	25.47	20.13	45.60	56.00	-10.40	QP	
8	1.2740	24.75	20.13	44.88	46.00	-1.12	AVG	
9	1.4700	23.92	20.13	44.05	56.00	-11.95	QP	
10	1.4740	23.02	20.13	43.15	46.00	-2.85	AVG	
11	1.6660	21.67	20.13	41.80	46.00	-4.20	AVG	
12	21.6620	26.90	20.32	47.22	60.00	-12.78	QP	

Note: Result=Reading+Factor Over Limit=Result-Limit

3. Power Line Conducted Emission Test (Wired Network Ports)

3.1. Test Standard and Limit

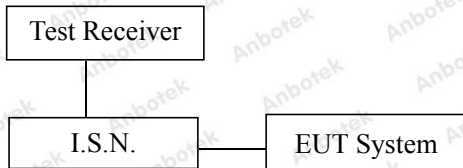
Test Standard	EN 55032
---------------	----------

Limits for conducted emissions

Test Limit	Frequency (MHz)	At mains terminals (dB μ V)	
		Quasi-peak Level	Average Level
	0.15 ~ 0.50	84 ~ 74*	74 ~ 64*
	0.50 ~ 30.00	74	64

Remark: (1) The lower limit shall apply at the transition frequencies.
 (2) The limit decreases linearly with the logarithm of the frequency in the range 0.15MHz to 0.50MHz.

3.2. Test Setup



3.3. EUT Configuration on Measurement

The following equipments are installed on Power Line Conducted Emission Measurement to meet the commission requirement and operating regulations in a manner which tends to maximize its emission characteristics in a normal application.

3.4. Operating Condition of EUT

- 3.4.1. Setup the EUT as shown in Section 3.2.
- 3.4.2. Turn on the power of all equipments.
- 3.4.3. Let the EUT work in test mode and measure it.

3.5. Test Procedure

The EUT is put on the plane 0.8 m high above the ground by insulating support and connected to the wired network ports through Impedance Stabilization Network(ISN). and it is investigated to find out the maximum conducted emission according to the EN55032 regulations during conducted emission measurement.

The bandwidth of the field strength meter (R&S Test Receiver ESCI) is set at 9kHz in 150kHz~30MHz.

The frequency range from 150KHz to 30MHz is checked.

All the test results are listed in Section 3.6.

3.6. Test Results

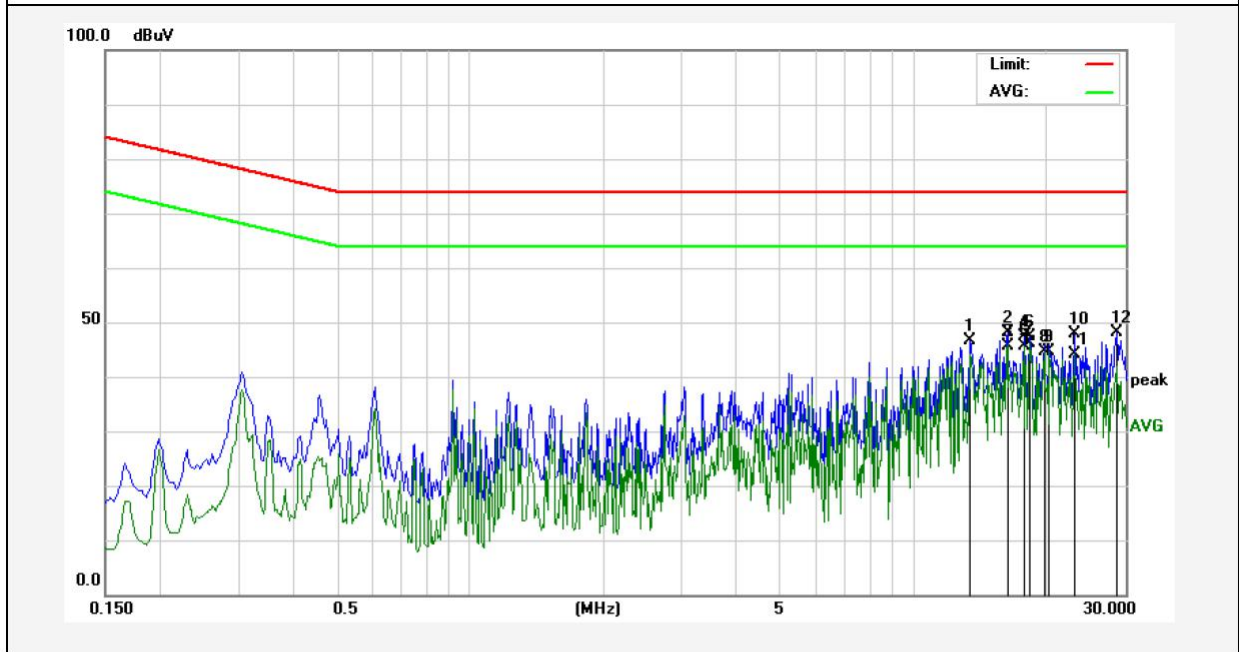
PASS

The frequency range 150kHz to 30MHz is investigated

The test curves are shown in the following pages.

Conducted Emission Test Data

Test Site: 1# Shielded Room
 Test Specification: DC 24V
 Comment: Signal Line
 Temp.: 26°C Hum.: 53%



No.	Freq. (MHz)	Reading (dBuV)	Factor (dB)	Result (dBuV)	Limit (dBuV)	Over Limit (dB)	Detector	Remark
1	13.3580	37.13	9.55	46.68	74.00	-27.32	QP	
2	16.2300	38.46	9.57	48.03	74.00	-25.97	QP	
3	16.2300	36.18	9.57	45.75	64.00	-18.25	AVG	
4	17.6940	37.75	9.59	47.34	74.00	-26.66	QP	
5	17.6940	36.13	9.59	45.72	64.00	-18.28	AVG	
6	18.2420	37.76	9.60	47.36	74.00	-26.64	QP	
7	18.2420	36.45	9.60	46.05	64.00	-17.95	AVG	
8	19.7099	35.01	9.62	44.63	64.00	-19.37	AVG	
9	20.2580	34.93	9.62	44.55	64.00	-19.45	AVG	
10	23.1299	38.23	9.66	47.89	74.00	-26.11	QP	
11	23.1299	34.54	9.66	44.20	64.00	-19.80	AVG	
12	28.6860	38.44	9.72	48.16	74.00	-25.84	QP	

Note: Result=Reading+Factor Over Limit=Result-Limit

4. Radiated Emission Test

4.1. Test Standard and Limit

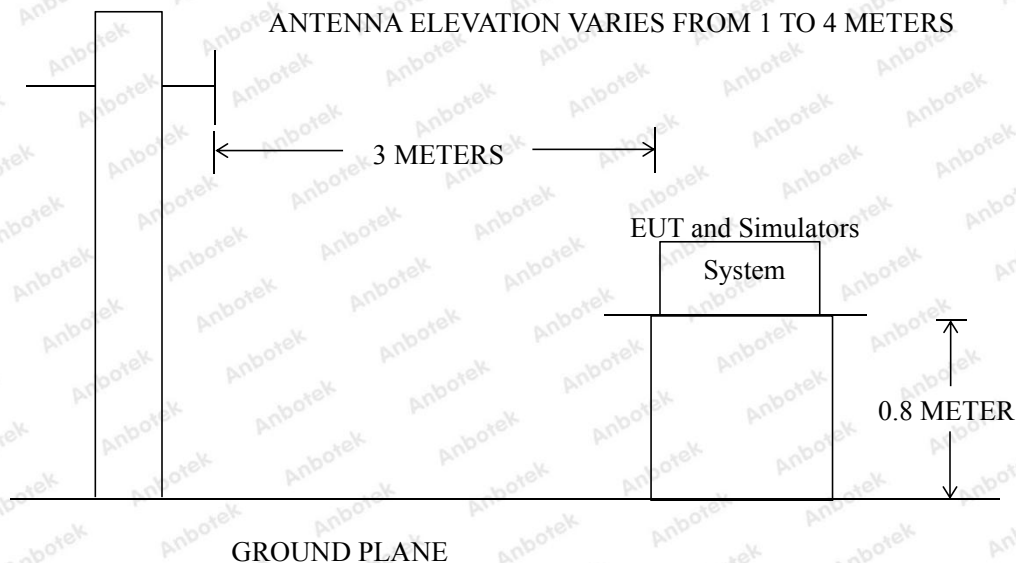
Test Standard	EN 55032
---------------	----------

Radiated Emission Test Limit

Test Limit	Frequency (MHz)	DISTANCE (Meters)	FIELD STRENGTHS LIMIT (dB μ V/m)
	30 ~ 230	3	40
	230 ~ 1000	3	47

Remark: (1) The smaller limit shall apply at the combination point between two frequency bands.
 (2) Distancer refers to the distance in meters between the measuring instrument antenna and the closed point of any part of the EUT.
 (3) $3M \text{ Limit} = 10M \text{ Limit} + k$ $k = 20 \log(D1/D2) = 10$
 $3M \text{ Limit} = 10M \text{ Limit} + 10$
 (D1= 10M D2=3M)

4.2. Test Setup



4.3. EUT Configuration on Measurement

The EN 55032 regulations test method must be used to find the maximum emission during radiated emission measurement.

4.4. Operating Condition of EUT

4.4.1. Setup the EUT as shown in Section 4.2.

4.4.2. Turn on the power of all equipments.

4.4.3. Let the EUT work in test mode and measure it.

4.5. Test Procedure

The EUT is placed on a turn table which is 0.8 meter high above the ground. The turn table can rotate 360 degrees to determine the position of the maximum emission level. The EUT is set 3 meters away from the receiving antenna which is mounted on a antenna tower. The antenna can be moved up and down from 1 to 4 meters to find out the maximum emission level. Bilog antenna is used as a receiving antenna. Both horizontal and vertical polarization of the antenna are set on test.

The bandwidth of the Receiver (ESCI) is set at 120kHz.

The EUT is tested in 9*6*6 Chamber.

The test results are listed in Section 4.6.

4.6. Test Results

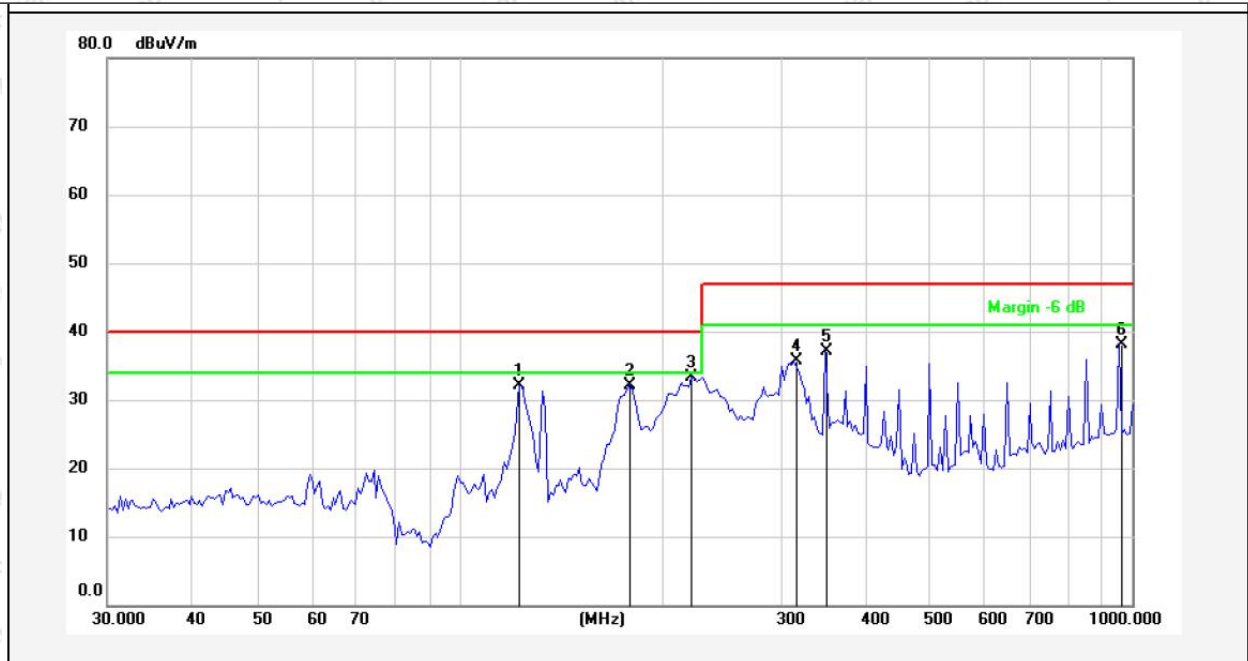
PASS

The frequency range from 30MHz to 1000MHz is investigated.

The test curves are shown in the following pages.



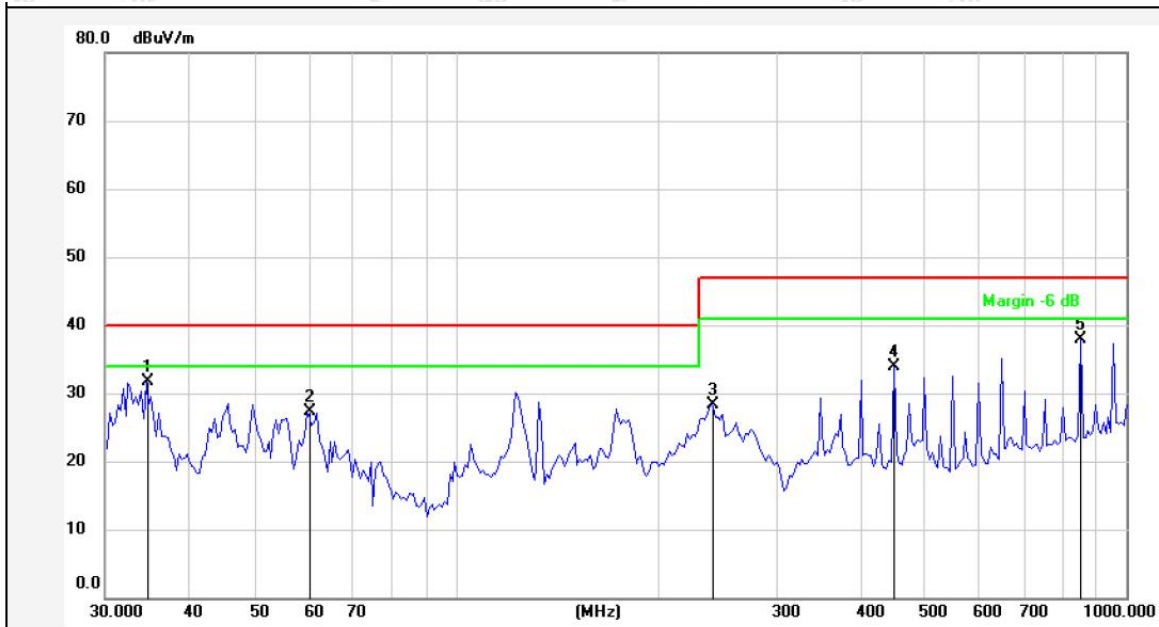
Test item: Radiation Test **Polarization:** Horizontal
Standard: (RE)EN55032 **Power Source:** DC 24V
Distance: 3m **Temp.(°C)/Hum.(%RH):** 23(°C)/56%RH



No.	Freq. (MHz)	Reading (dBuV)	Factor ()	Result (dBuV/m)	Limit (dBuV/m)	Over Limit (dB)	Detector	Height (cm)	degree (deg)	Remark
1	123.0495	56.60	-24.40	32.20	40.00	-7.80	peak			
2	179.3863	54.98	-22.78	32.20	40.00	-7.80	peak			
3	221.3921	55.38	-22.00	33.38	40.00	-6.62	peak			
4	314.3765	54.06	-18.44	35.62	47.00	-11.38	peak			
5	349.2500	53.83	-16.74	37.09	47.00	-9.91	peak			
6	957.1148	46.13	-8.05	38.08	47.00	-8.92	peak			

Note: Result=Reading+Factor Over Limit=Result-Limit

Test item: Radiation Test **Polarization:** Vertical
Standard: (RE)EN55032 **Power Source:** DC 24V
Distance: 3m **Temp.(°C)/Hum.(%RH):** 23(°C)/56%RH



No.	Freq. (MHz)	Reading (dBuV)	Factor ()	Result (dBuV/m)	Limit (dBuV/m)	Over Limit (dB)	Detector	Height (cm)	degree (deg)	Remark
1	34.5173	48.48	-16.85	31.63	40.00	-8.37	peak			
2	59.9639	43.80	-16.41	27.39	40.00	-12.61	peak			
3	239.5670	44.62	-16.22	28.40	47.00	-18.60	peak			
4	450.3447	48.82	-14.88	33.94	47.00	-13.06	peak			
5	854.0247	46.11	-8.21	37.90	47.00	-9.10	peak			

Note: Result=Reading+Factor Over Limit=Result-Limit

5. Electrostatic Discharge Immunity Test

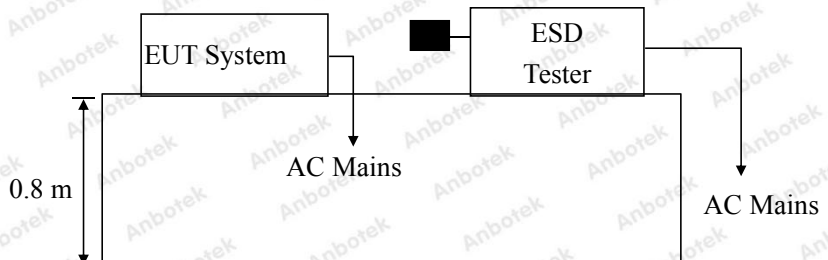
5.1. Test Standard and Level

Test Standard:	EN 55035 (IEC 61000-4-2)
Performance Criterion:	B
Severity Level: 3 / Air Discharge: ± 8 kV, Level: 2 / Contact Discharge: ± 4 kV	

Test Level

Level	Test Voltage Contact Discharge (kV)	Test Voltage Air Discharge (kV)
1.	± 2	± 2
2.	± 4	± 4
3.	± 6	± 8
4.	± 8	± 15
X.	Special	Special

5.2. Test Setup



5.3. EUT Configuration on Measurement

The following equipments are installed on electrostatic discharge immunity measurement to meet EN 55035 requirements and operating in a manner which tends to maximize its emission characteristics in a normal application.

5.4. Operating Condition of EUT

- 5.4.1. Setup the EUT as shown on Section 5.2.
- 5.4.2. Turn on the power of all equipments.
- 5.4.3. After that, let the EUT work in test mode measure it.

5.5. Test Procedure

5.5.1. Air Discharge:

This test is done on a non-conductive surface. The round discharge tip of the discharge electrode shall be approached as fast as possible to touch the EUT. After each discharge, the discharge electrode shall be removed from the EUT. The generator is then re-triggered for a new single discharge and repeated 10 times for each pre-selected test point. This procedure shall be repeated until all the air discharge completed

5.5.2. Contact Discharge:

All the procedure shall be same as Section 5.5.1. except that the tip of the discharge electrode shall touch the EUT before the discharge switch is operated.

5.5.3. Indirect discharge for horizontal coupling plane

At least 20 single discharges shall be applied to the horizontal coupling plane, at points on each side of the EUT. The discharge electrode positions vertically at a distance of 0.1m from the EUT and with the discharge electrode touching the coupling plane.

5.5.4. Indirect discharge for vertical coupling plane

At least 20 single discharge shall be applied to the center of one vertical edge of the coupling plane. The coupling plane, of dimensions 0.5m × 0.5m, is placed parallel to, and positioned at a distance of 0.1m from the EUT. Discharges shall be applied to the coupling plane, with this plane in sufficient different positions that the four faces of the EUT are completely illuminated.

5.6. Test Results

PASS

Please refer to the following page.



Electrostatic Discharge Test Results

Air discharge :	±8.0kV	Temperature :	23.0°C
Contact discharge :	±4.0kV	Humidity :	53%
Power Supply :	DC 24V	Expert conclusion:	A
Number of discharge :	10	Test Result:	<input checked="" type="checkbox"/> Pass <input type="checkbox"/> Fail

Location		Kind A-Air Discharge C-Contact Discharge	Result
LAN Port	4 points	C	<input checked="" type="checkbox"/> A <input type="checkbox"/> B <input type="checkbox"/> C <input type="checkbox"/> D
Button	4 points	A	<input checked="" type="checkbox"/> A <input type="checkbox"/> B <input type="checkbox"/> C <input type="checkbox"/> D
USB Port	2 points	C	<input checked="" type="checkbox"/> A <input type="checkbox"/> B <input type="checkbox"/> C <input type="checkbox"/> D
Screen	2 points	A	<input checked="" type="checkbox"/> A <input type="checkbox"/> B <input type="checkbox"/> C <input type="checkbox"/> D
Slot	8 points	A	<input checked="" type="checkbox"/> A <input type="checkbox"/> B <input type="checkbox"/> C <input type="checkbox"/> D
HCP	4 points	C	<input checked="" type="checkbox"/> A <input type="checkbox"/> B <input type="checkbox"/> C <input type="checkbox"/> D
VCP of the front	4 points	C	<input checked="" type="checkbox"/> A <input type="checkbox"/> B <input type="checkbox"/> C <input type="checkbox"/> D
VCP of the rear	4 points	C	<input checked="" type="checkbox"/> A <input type="checkbox"/> B <input type="checkbox"/> C <input type="checkbox"/> D
VCP of the left	4 points	C	<input checked="" type="checkbox"/> A <input type="checkbox"/> B <input type="checkbox"/> C <input type="checkbox"/> D
VCP of the right	4 points	C	<input checked="" type="checkbox"/> A <input type="checkbox"/> B <input type="checkbox"/> C <input type="checkbox"/> D

Remark: Discharge should be considered on Contact and Air and Horizontal Coupling Plane (HCP) and Vertical Coupling Plane (VCP).

6. RF Field Strength Susceptibility Test

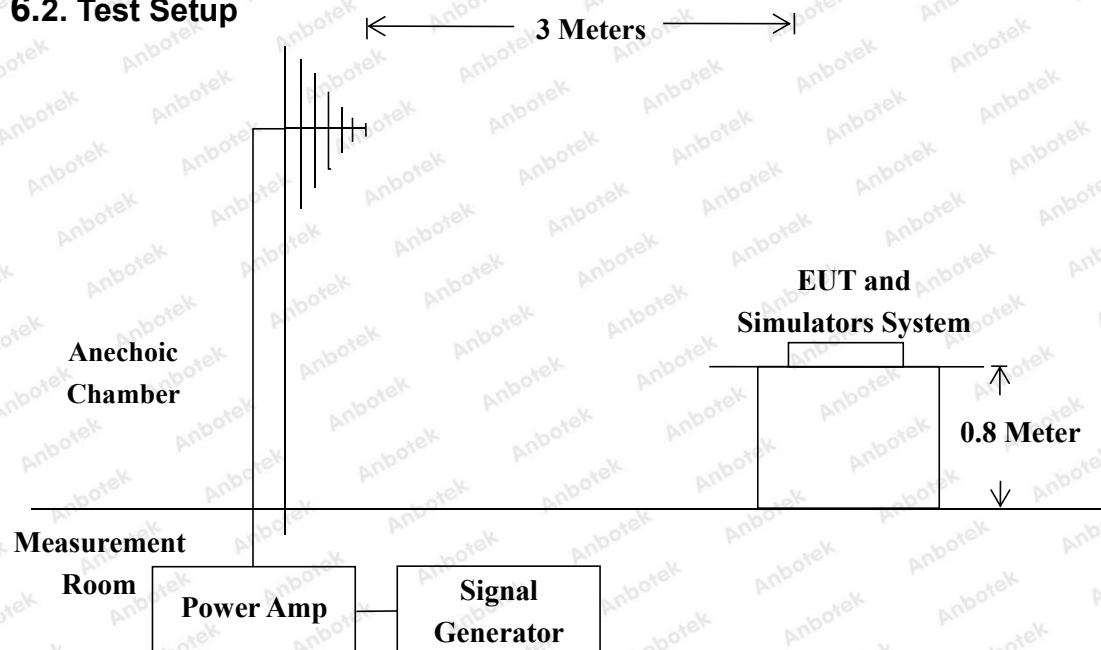
6.1. Test Standard and Level

Test Standard:	EN 55035 (IEC 61000-4-3)
Required Performance:	A
Frequency Range:	80MHz to 1000MHz, 1800MHz, 2600MHz, 3500MHz, 5000MHz
Field Strength:	3 V/m
Modulation:	1kHz Sine Wave, 80%, AM Modulation
Frequency Step:	1 % of preceding frequency value
Polarity of Antenna:	Horizontal and Vertical
Test Distance:	3 m
Antenna Height:	1.5 m
Dwell Time:	at least 0.5s

Test Level

Level	Field Strength V/m
1.	1
2.	3
3.	10
X.	Special

6.2. Test Setup



6.3. EUT Configuration on Measurement

The following equipments are installed on RF Field Strength susceptibility Measurement to meet EN 55035 requirements and operating in a manner which tends to maximize its emission characteristics in a normal application.

6.4. Operating Condition of EUT

6.4.1. Setup the EUT as shown on Section 6.2.

6.4.2. Turn on the power of all equipments.

6.4.3. After that, let the EUT work in test mode measure it.

6.5. Test Procedure

The EUT and support equipment, which are placed on a table that is 0.8 meter above ground and the testing was performed in a fully-anechoic chamber. The testing distance from antenna to the EUT was 3 meters.

- 1) 80 MHz to 1000 MHz the field strength level was 3V/m, 1800MHz, 2600MHz, 3500MHz, 5000MHz the field strength level was 3V/m.
- 2) The frequency range is swept from 80 MHz to 1000 MHz with the signal 80% amplitude modulated with a 1kHz sine wave.
- 3) The frequency range is swept from 1800MHz, 2600MHz, 3500MHz, 5000MHz with the signal 80% amplitude modulated with a 1kHz sine wave.
- 4) The dwell time at each frequency shall be not less than the time necessary for the EUT to be able to respond, but shall in no case be less than 0.5s.
- 5) The test was performed with the EUT exposed to both vertically and horizontally polarized fields on each of the four sides.

6.6. Measuring Results

PASS

Please refer to the following page.



RF Field Strength Susceptibility Test Results

Field Strength :	3V/m	Temperature :	23.0°C
Expert conclusion:	A	Humidity :	53%
Power Supply :	DC 24V	Test Result :	<input checked="" type="checkbox"/> Pass <input type="checkbox"/> Fail
Dwell Time:	1s		

Frequency Range	Antenna Polarity	R.F. Field Strength	Azimuth	Result
80MHz~1000MHz	H / V	3 V/m (rms)	Front	<input checked="" type="checkbox"/> A <input type="checkbox"/> B <input type="checkbox"/> C <input type="checkbox"/> D
			Rear	
			Left	
			Right	
1800MHz 2600MHz 3500MHz 5000MHz	H / V	3 V/m (rms)	Front	<input checked="" type="checkbox"/> A <input type="checkbox"/> B <input type="checkbox"/> C <input type="checkbox"/> D
			Rear	
			Left	
			Right	

7. Electrical Fast Transient/Burst Immunity Test

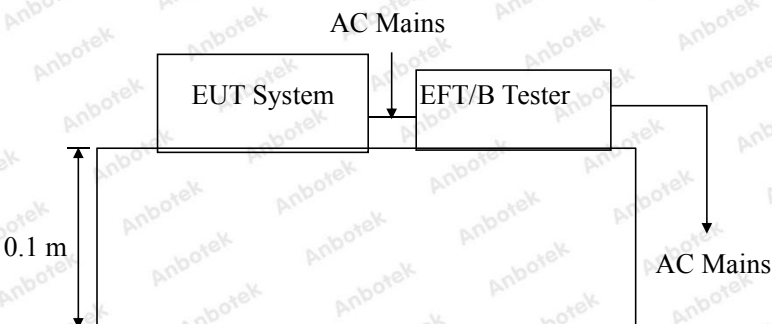
7.1. Test Standard and Level

Test Standard:	EN 55035 (IEC 61000-4-4)
Performance criterion:	B
Severity Level 1: 0.50kV	

Test Level

Open Circuit Output Test Voltage $\pm 10\%$		
Level	On Power Supply Lines	On I/O (Input/Output) Signal data and control lines
1.	0.50 kV	0.25 kV
2.	1.00 kV	0.50 kV
3.	2.00 kV	1.00 kV
4.	4.00 kV	2.00 kV
X.	Special	Special

7.2. Test Setup



7.3. EUT Configuration on Measurement

The following equipments are installed on electrical fast transient/burst immunity measurement to meet EN 55035 requirements and operating in a manner which tends to maximize its emission characteristics in a normal application.

7.4. Operating Condition of EUT

7.4.1. Setup the EUT as shown in Section 7.2.

7.4.2. Turn on the power of all equipments.

7.4.3. Let the EUT work in test mode and measure it.

7.5. Test Procedure

The EUT is put on the table which is 0.1 meter high above the ground. This reference ground plane shall project beyond the EUT by at least 0.1m on all sides and the minimum distance between EUT and all other conductive structure, except the ground plane beneath the EUT, shall be more than 0.5m.

7.5.1. For input and output AC power ports:

The EUT is connected to the Power mains by using a coupling device which couples the EFT interference signal to AC Power lines. Both polarities of the test voltage should be applied during compliance test and the duration of the test is 2 mins.

7.5.2. For signal lines and control lines ports:

Select tests based on product characteristics.

7.5.3. For DC output line ports:

Select tests based on product characteristics.

7.6. Test Results

PASS

Please refer to the following page.



Electrical Fast Transient/Burst Test Results

Ambient Condition : 23.0°C / 53% RH		Expert conclusion: A	
Power Supply .: DC 24V		Test Result : <input checked="" type="checkbox"/> Pass <input type="checkbox"/> Fail	
Inject Line : AC Mains		Inject Method: Direct	Inject Time(s): 120
Line	Polarity	Test Voltage (kV)	Result
AC Line			
DC Line	±	0.50kV	<input checked="" type="checkbox"/> A <input type="checkbox"/> B <input type="checkbox"/> C <input type="checkbox"/> D
Signal Line			

8. Surge Immunity Test

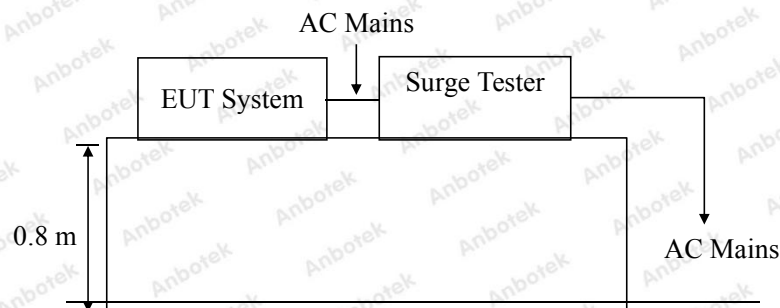
8.1. Test Standard and Level

Test Standard:	EN 55035 (IEC 61000-4-5)
Performance criterion:	B
Severity Level 1, Line to Line: 0.5kV	

Test Level

Severity Level	Open-Circuit Test Voltage (kV)
1.	0.5
2.	1.0
3.	2.0
4.	4.0
X.	Special

8.2. Test Setup



8.3. EUT Configuration on Measurement

The following equipments are installed on surge immunity measurement to meet EN 55035 requirements and operating in a manner which tends to maximize its emission characteristics in a normal application.

8.4. Operating Condition of EUT

- 8.4.1. Setup the EUT as shown in Section 8.2.
- 8.4.2. Turn on the power of all equipments.
- 8.4.3. Let the EUT work in test mode and measure it.

8.5. Test Procedure

8.5.1. Set up the EUT and test generator as shown on Section 8.2.

8.5.2. For line to line coupling mode, provide a 1.0 kV 1.2/50us voltage surge (at open-circuit condition) and 8/20us current surge to EUT selected points.

8.5.3. At least 5 positive and 5 negative (polarity) tests with a maximum 1/min repetition rate are conducted during test.

8.5.4. Different phase angles are done individually.

8.5.5. Record the EUT operating situation during compliance test and decide the EUT immunity criterion for above each test.

8.6. Test Results

PASS

Please refer to the following page.



Surge Immunity Test Results

Humidity :	53%	Temperature :	23.0°C		
Power Supply :	DC 24V	Expert conclusion:	A		
Test Result :	<input checked="" type="checkbox"/> Pass <input type="checkbox"/> Fail				
Location	Polarity	Phase Angle	Number of Pulse	Pulse Voltage (kV)	Result
Positive-Negative	+	/	5	0.5	A
Positive-Negative	-	/	5	0.5	A
Positive-PE					
Negative-PE					

9. Injected Currents Susceptibility Test

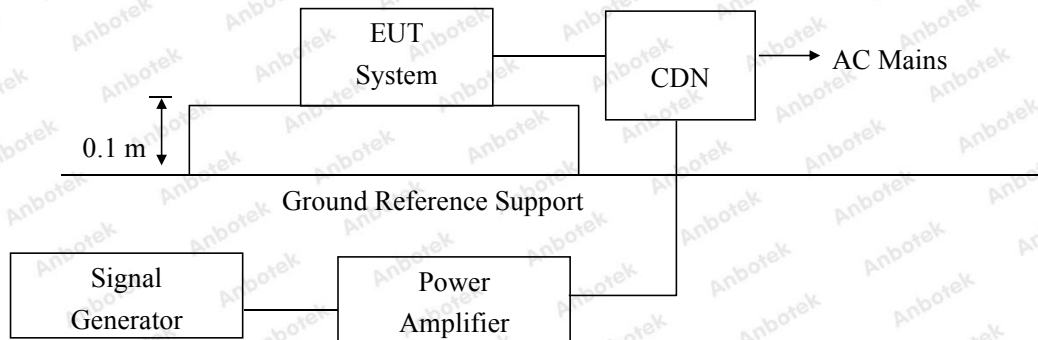
9.1. Test Standard and Level

Test Standard	EN 55035 (IEC 61000-4-6)
Performance criterion	A

Test Level

Level	Field Strength V
1.	1
2.	3
3.	10
X.	Special

9.2. Test Setup



9.3. EUT Configuration

The following equipments are installed on currents susceptibility measurement to meet EN 55035 requirements and operating in a manner which tends to maximize its emission characteristics in a normal application.

9.4. Operating Condition of EUT

9.4.1. Setup the EUT as shown in Section 9.2.

9.4.2. Turn on the power of all equipments.

9.4.3. Let the EUT work in test mode and measure it.

9.5. Test Procedure

- 1) Set up the EUT, CDN and test generators as shown on Section 9.2.
- 2) Let the EUT work in test mode and measure it.
- 3) The EUT are placed on an insulating support 0.1m high above a ground reference plane. CDN (coupling and decoupling device) is placed on the ground plane about 0.3m from EUT. Cables between CDN and EUT are as short as possible, and their height above the ground reference plane shall be between 30 and 50 mm (where possible).
- 4) The disturbance signal described below is injected to EUT through CDN.
- 5) The EUT operates within its operational mode(s) under intended climatic conditions after power on.
- 6) The frequency range is swept from 150KHz to 10MHz using 3V signal level, 10MHz to 30MHz using 3V to 1V signal level, 30MHz to 80MHz using 1V signal level, and with the disturbance signal 80% amplitude modulated with a 1KHz sine wave.
- 7) The rate of sweep shall not exceed 1.5×10^{-3} decades/s. Where the frequency is swept incrementally, the step size shall not exceed 1% of the start and thereafter 1% of the preceding frequency value.
- 8) Recording the EUT operating situation during compliance testing and decide the EUT immunity criterion.

9.5.1. For signal lines and control lines ports:

Select tests based on product characteristics.

9.5.2. For DC output line ports:

Select tests based on product characteristics.

9.6. Test Results

PASS

Please refer to the following page.



Injected Currents Susceptibility Test Results

Humidity : 53%		Temperature : 23.0°C	
Power Supply : DC 24V		Expert conclusion: A	
Test Result : <input checked="" type="checkbox"/> Pass <input type="checkbox"/> Fail			
Frequency Range (MHz)		Injected Position	
Strength (Unmodulated)		Result	
0.15 ~ 10	DC Mains	3V	<input checked="" type="checkbox"/> A <input type="checkbox"/> B <input type="checkbox"/> C <input type="checkbox"/> D
10 ~ 30	DC Mains	3V to 1V	<input checked="" type="checkbox"/> A <input type="checkbox"/> B <input type="checkbox"/> C <input type="checkbox"/> D
30 ~ 80	DC Mains	1V	<input checked="" type="checkbox"/> A <input type="checkbox"/> B <input type="checkbox"/> C <input type="checkbox"/> D
<p>Remark : 1. Modulation Signal:1KHz 80% AM</p>			

APPENDIX I -- TEST SETUP PHOTOGRAPH

Photo of Power Line Conducted Emission Test



Photo of Radiated Emission Test



Photo of Electrostatic Discharge Immunity Test



Photo of RF Field Strength susceptibility Test

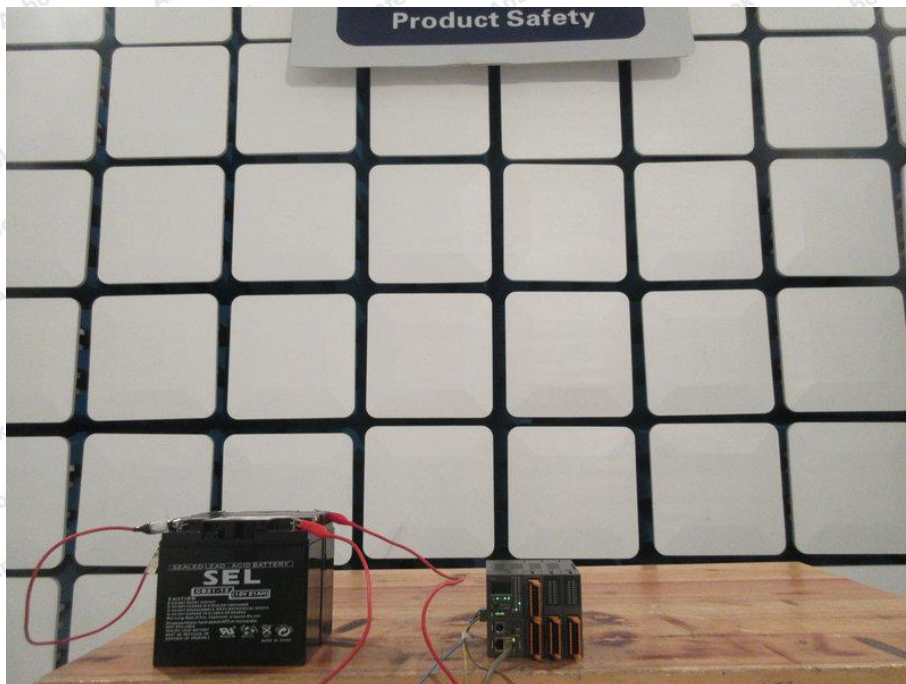


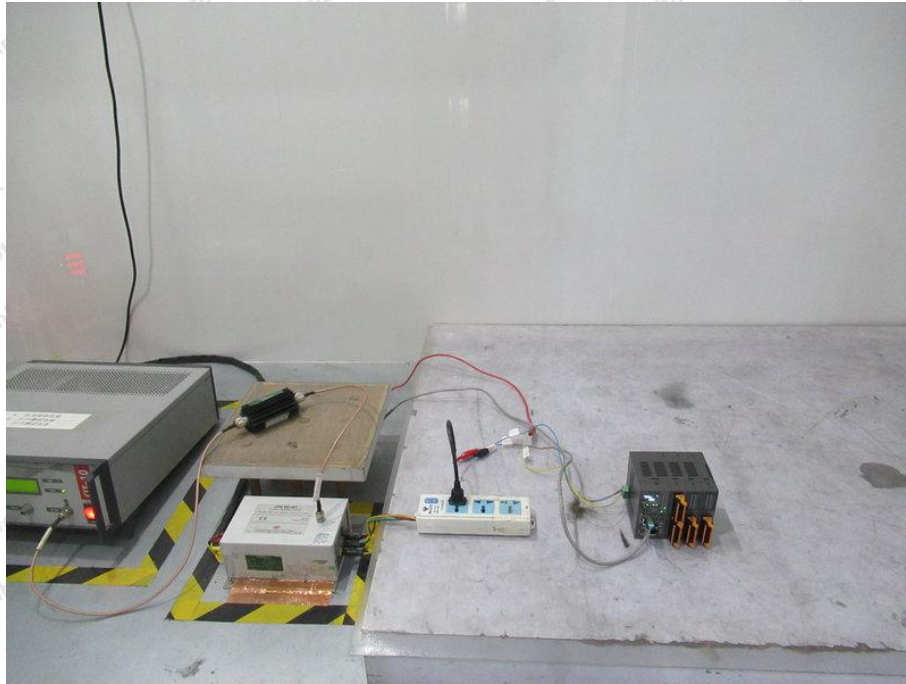
Photo of Electrical Fast Transient/Burst Immunity Test



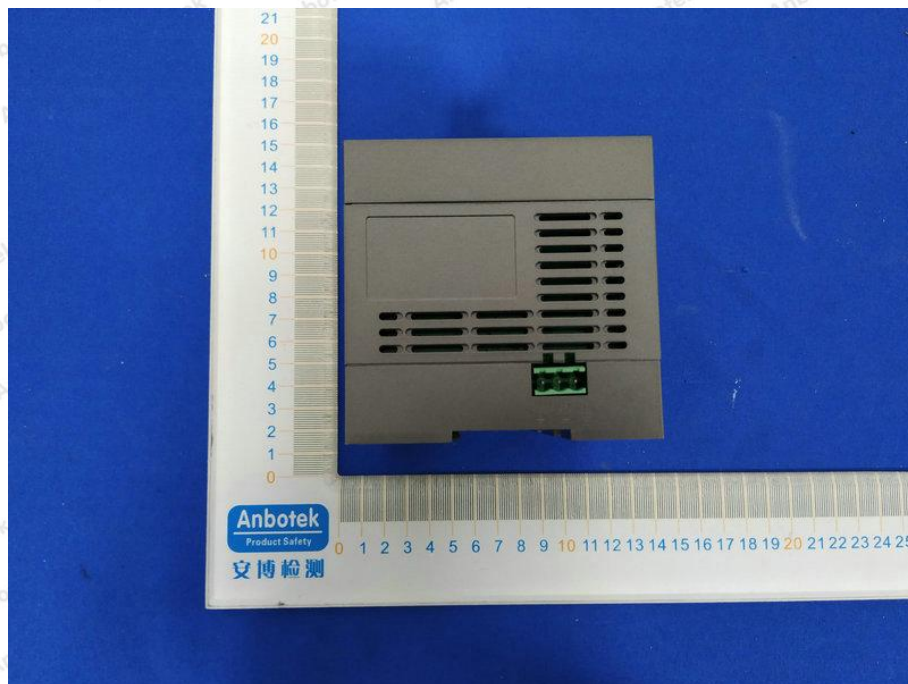
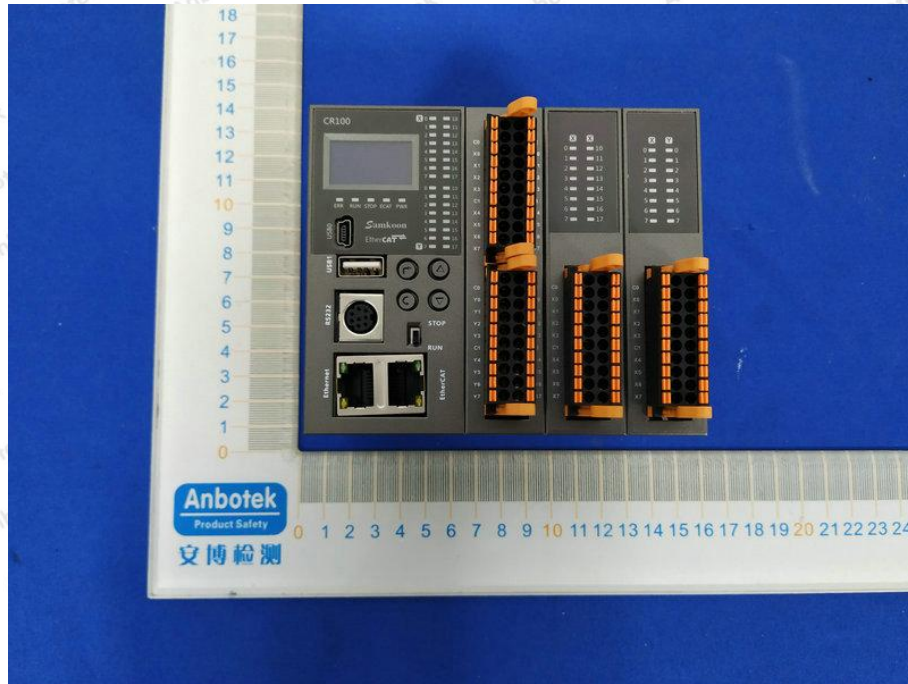
Photo of Surge Immunity Test

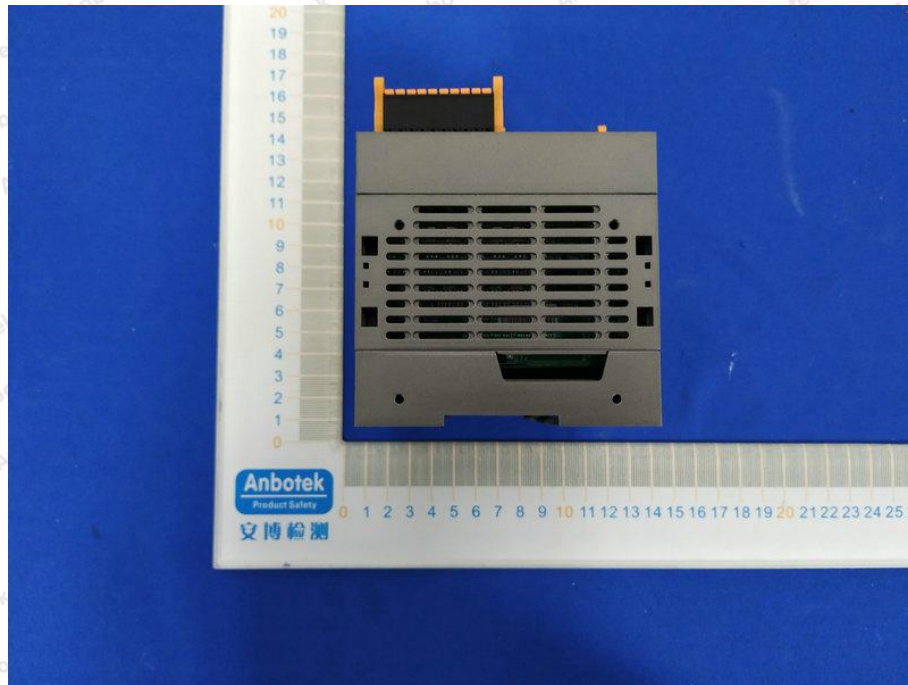


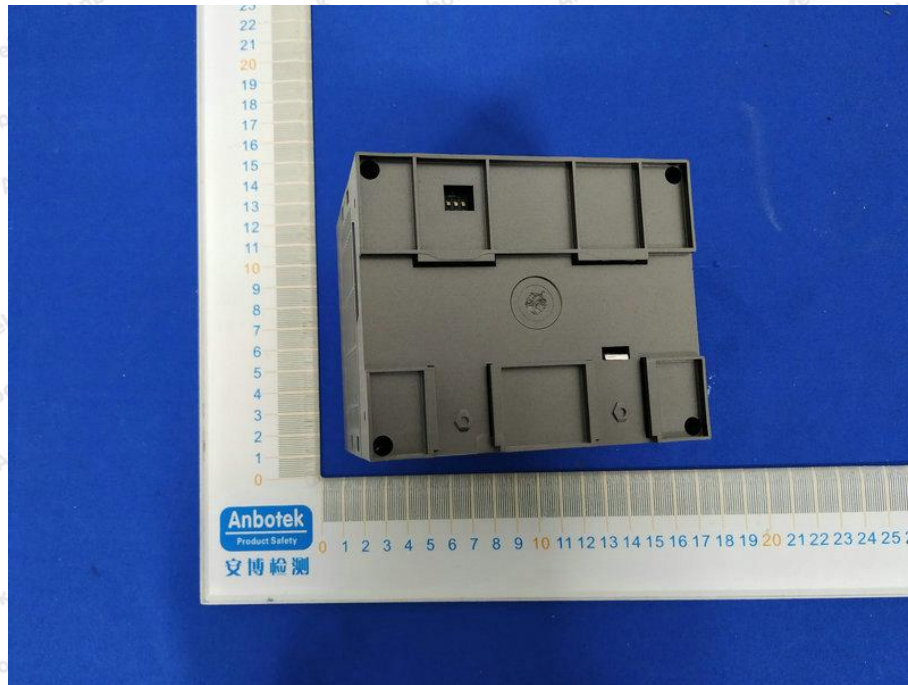
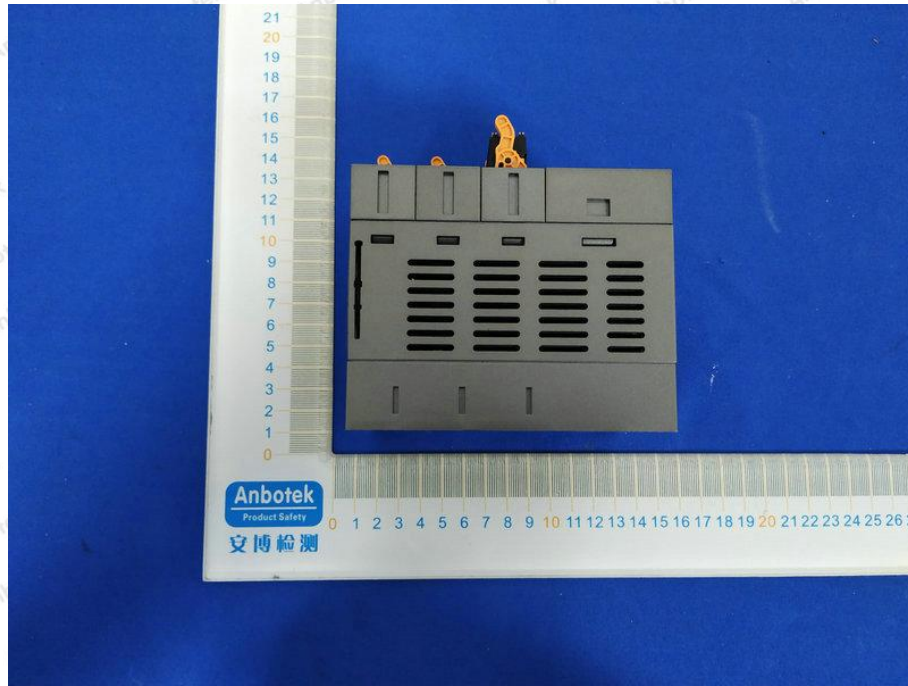
Photo of Injected currents susceptibility Test



APPENDIX II -- EXTERNAL PHOTOGRAPH

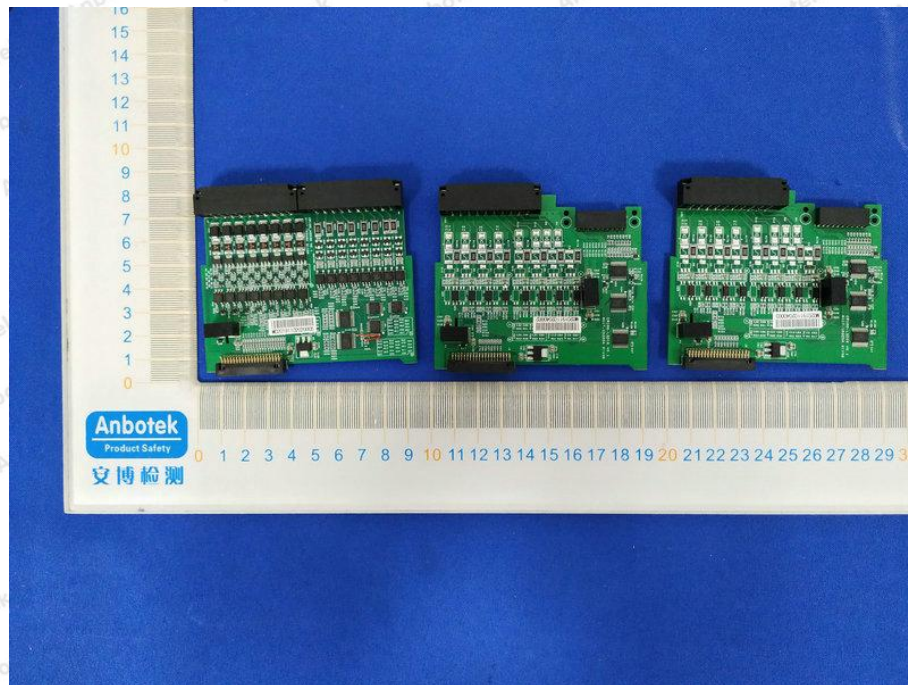
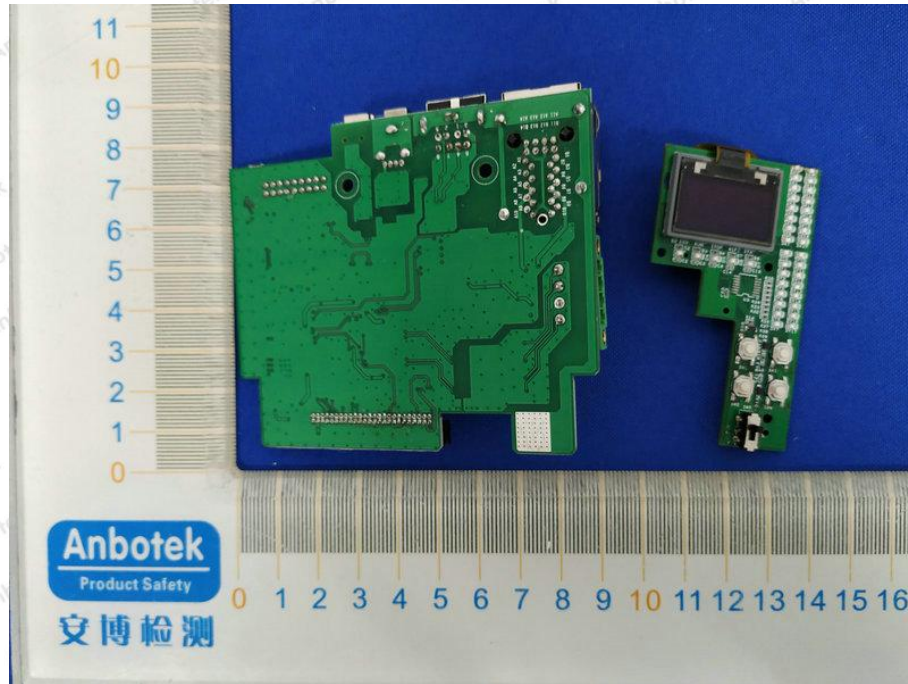


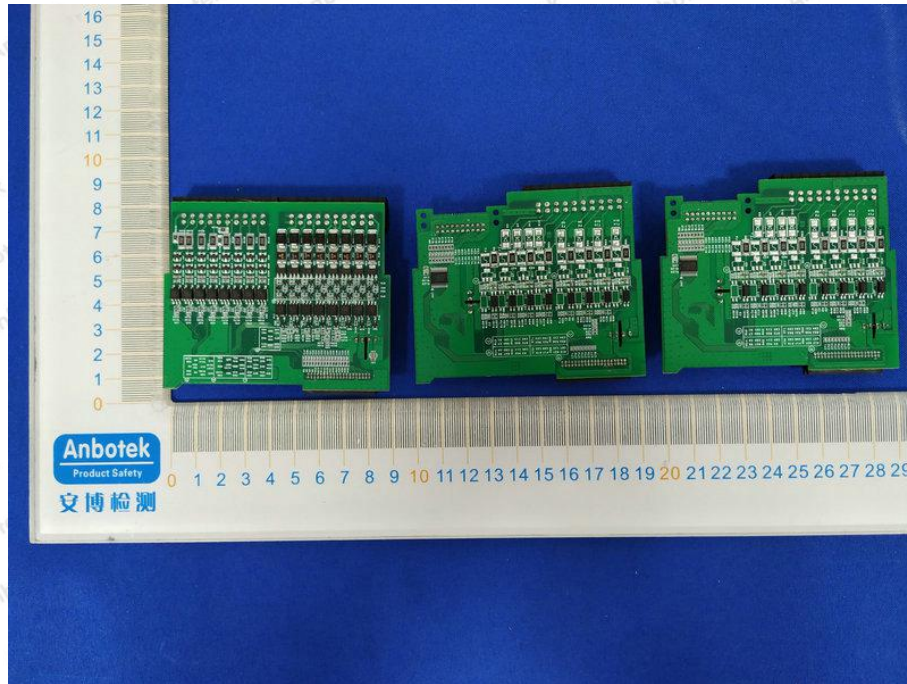




APPENDIX III -- INTERNAL PHOTOGRAPH









CE Label

1. The CE conformity marking must consist of the initials 'CE' taking the following form:

If the CE marking is reduced or enlarged, the proportions given in the above graduated drawing must be respected.

2. The CE marking must have a height of at least 5 mm except where this is not possible on account of the nature of the apparatus.

3. The CE marking must be affixed to the product or to its data plate. Additionally it must be affixed to the packaging, if any, and to the accompanying documents.

4. The CE marking must be affixed visibly, legibly and indelibly.

It must have the same height as the initials 'CE'.

----- End of Report -----

